

–weishaupt–

# manual

Installation and operating instruction

---

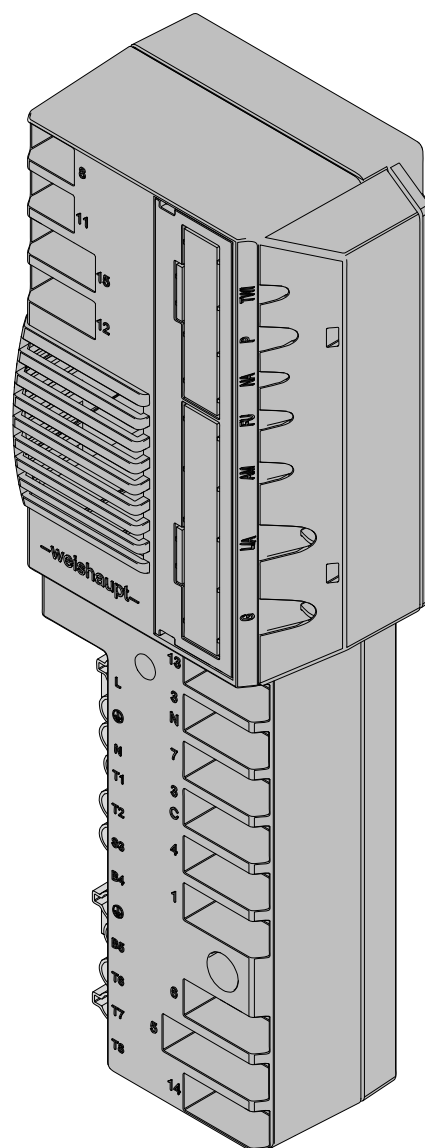

## Conformity certification

6004000002

Manufacturer: **Max Weishaupt GmbH**

Address: **Max-Weishaupt-Straße  
D-88475 Schwendi**

Product: Combustion Manager

**W-FM 25**

The product described above conforms with

the regulations of directives:

GAD	2009 / 142 / EC
PED	97 / 23 / EC
LVD	2006 / 95 / EC
EMC	2004 / 108 / EC

This product is labelled as follows:

**CE**  
**CE-0085**

Schwendi, 02.09.2014

ppa.



Dr. Schloen

Manager Research  
and Development

ppa.



Denking

Manager Production and  
Quality Management

<b>1</b>	<b>User instructions</b>	<b>5</b>
1.1	User guide	5
1.1.1	Symbols	5
1.1.2	Target group	5
1.2	Guarantee and Liability	6
<b>2</b>	<b>Safety</b>	<b>7</b>
2.1	Designated application	7
2.2	When gas can be smelled	7
2.3	Safety measures	7
2.3.1	Normal operation	7
2.3.2	Electrical connection	7
2.3.3	Gas supply	8
2.4	Alterations to the construction of the equipment	8
2.5	Noise emission	8
2.6	Disposal	8
<b>3</b>	<b>Product description</b>	<b>9</b>
3.1	Inputs and outputs	9
3.1.1	Gas burner	9
3.1.2	Gas burner with speed control	10
3.1.3	Oil burner	11
3.1.4	Dual fuel burner	12
3.2	Technical data	13
3.2.1	Electrical data	13
3.2.2	Ambient conditions	13
3.2.3	Dimensions	13
<b>4</b>	<b>Operation</b>	<b>14</b>
4.1	Operating panel	14
4.2	Display	16
4.2.1	Info level	17
4.2.2	Service level	20
4.2.3	Parameter level	23
4.2.4	Access level	28
4.3	Linearisation	29
<b>5</b>	<b>Installation</b>	<b>30</b>
5.1	Replacing the combustion manager	30
<b>6</b>	<b>Commissioning</b>	<b>32</b>
6.1	Gas burner	32
6.2	Gas burner with speed control	37
6.3	Oil burner	42
6.4	Dual fuel burner	47
6.4.1	Adjusting gas side	47
6.4.2	Adjusting oil side	52

<b>7</b>	<b>Troubleshooting</b>	<b>57</b>
7.1	Procedures for fault conditions	57
7.1.1	Display off	57
7.1.2	Display flashes	57
7.1.3	Detailed fault code	58
7.2	Rectifying faults	59
<b>8</b>	<b>Spares</b>	<b>64</b>
<b>9</b>	<b>Technical documentation</b>	<b>66</b>
9.1	Program sequence	66
<b>10</b>	<b>Notes</b>	<b>68</b>
<b>11</b>	<b>Key word index</b>	<b>70</b>

**1 User instructions**

**1 User instructions**

This installation and operating manual forms part of the appliance and must be kept on site.

Observe installation and operating manual of the burner.







This installation and operating manual supplements the following chapters in the installation and operating manual of the burner:

- Technical description and/or Product description
- Commissioning and operation and/or Commissioning
- Cause and rectification of faults and/or Troubleshooting
- Technical data.

The chapter Display and operating modes and operation is replaced completely.

**1.1 User guide**

**1.1.1 Symbols**

 <b>DANGER</b>	Immediate danger with high risk. Non observance can lead to serious injury or death.
 <b>WARNING</b>	Danger with medium risk. Non observance can lead to environmental damage, serious injury or death.
 <b>CAUTION</b>	Danger with low risk. Non observance can cause damage to the equipment and injury to personnel.
	Important information
	Requires direct action
	Result after an action
	Itemisation
...	Range of values

**1.1.2 Target group**

These installation and operating instructions are intended for the operator and qualified personnel. They should be observed by all personnel working on the unit.

Work on the unit must only be carried out by personnel who have the relevant training and instruction.

Persons with limited physical, sensory or mental capabilities may only work on the unit if they are supervised or have been trained by an authorised person.

Children must not play near or on the unit.

## 1 User instructions

### 1.2 Guarantee and Liability

Guarantee and liability claims for personal and equipment damage are excluded, if they can be attributed to one or more of the following causes:

- Non approved application,
- non-observance of the installation and operating instruction,
- operation with faulty safety equipment,
- continual operation despite a fault,
- improper installation, commissioning, operation and service,
- unauthorised modifications made to the unit,
- the installation of additional components, which have not been tested with the unit,
- the installation of combustion chamber inserts, which impede full flame formation,
- repairs, which have been carried out incorrectly,
- the use of non original Weishaupt parts,
- unsuitable fuels,
- defects in the inlet lines,
- acts of God.

## 2 Safety

## 2 Safety

### 2.1 Designated application

The combustion manager W-FM 25 is suitable for use with:

- oil burners
- gas burners
- dual fuel burners.

Improper use could:

- endanger the health and safety of the user or third parties,
- cause damage to the appliance or other material assets.

### 2.2 When gas can be smelled

Avoid open flames and spark generation, for example:

- do not operate light switches,
- do not operate electronic equipment,
- do not use mobile telephones.
- ▶ Open doors and windows.
- ▶ Close gas isolating valve.
- ▶ Warn the inhabitants (do not ring door bells).
- ▶ Leave the building.
- ▶ Inform the heating company or gas supplier from outside of the building.

### 2.3 Safety measures

Safety relevant fault conditions must be eliminated immediately.

#### 2.3.1 Normal operation

- All labels on the unit must be kept in a legible condition,
- the unit should only be operated with its cover in the closed position,
- do not touch moving parts during operation,
- stipulated settings, service and inspection work should be carried out at regular intervals.

#### 2.3.2 Electrical connection

For work carried out on live parts:

- Observe the accident prevention instructions BGV A3 and adhere to local directives,
- tools in accordance with EN 60900 should be used.

## 2 Safety

### 2.3.3 Gas supply

- Only the gas supplier or an approved agent may carry out installation, alteration and maintenance work on gas appliances in buildings and properties.
- Pipe work must be subject to a combined load and valve proving test and usability testing relative to the pressure range intended (e.g. DVGW-TRGI, work sheet G 600).
- Inform the gas supplier about the type and size of plant prior to installation.
- Local regulations and guidelines must be observed during installation (e. g. DVGW-TRGI, work sheet G 600; TRF Band 1 and Band 2).
- The gas supply pipe work should be suitable for the type and quality of gas and should be designed in such a way that it is not possible for liquids to form (e. g. condensate). Observe vaporisation pressure and vaporisation temperature of liquid petroleum gas.
- Use only tested and approved sealing materials, whilst observing all process information.
- Re-commission the appliance when changing to a different type of gas.
- Carry out soundness test after each service and fault rectification.

### 2.4 Alterations to the construction of the equipment

All conversions require written approval from Max Weishaupt GmbH.

- No additional components may be fitted, which have not been tested for use with the equipment,
- use only original Weishaupt replacement parts.

### 2.5 Noise emission

The noise emissions are determined by the acoustic behaviour of all components fitted to the combustion system.

Prolonged exposure to high noise levels can lead to loss of hearing. Provide operating personnel with protective equipment.

Noise emissions can further be reduced with a sound attenuator.

### 2.6 Disposal

Dispose of all materials used in a safe and environmentally friendly way. Observe local regulations.



**3 Product description**

**3 Product description**

**3.1 Inputs and outputs**

**3.1.1 Gas burner**

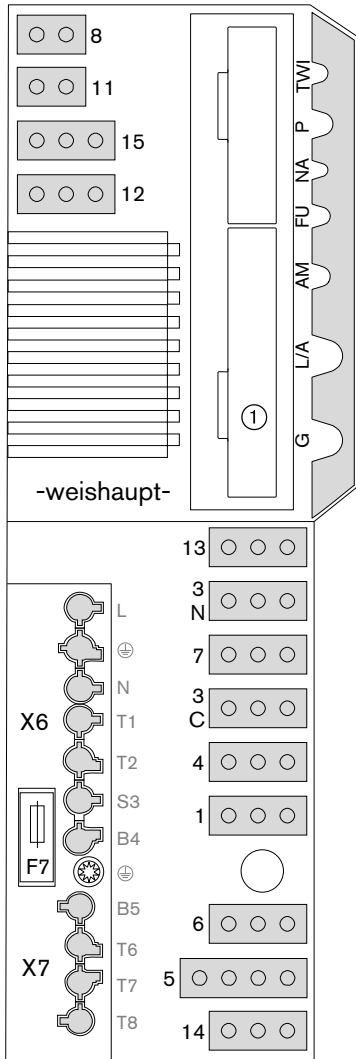

- TWI TWI interface (Vision Box)
- P free
- NA free
- FC free
- AM Operating panel of remote reset
- L/A Air damper actuator
- G Gas butterfly valve actuator
- ① Slot analogue module EM3/3 or Fieldbus module EM3/2
- 1 External liquid petroleum gas valve
- 3C Burner motor for continuous running fan
- 3N Burner motor or valve continuous running fan
- 4 Ignition unit
- 5 Multifunction assembly or double gas valve
- 6 free
- 7 Bridging plug No. 7
- 8 Gas meter (impulse generator)
- 11 Air pressure switch
- 12 Low / valve proving gas pressure switch
- 13 Ionisation
- 14 Remote reset (plug cable No. 14 required)
- 15 Bridging plug No. 15 or high gas pressure switch
- X6 7 pole connection plug
- X7 4 pole connection plug
- F7 Internal unit fuse (6.3 AT)



If a digital load converter (DLU) is used, this has to be replaced with the analogue module EM3/3.

**3 Product description**

**3.1.2 Gas burner with speed control**

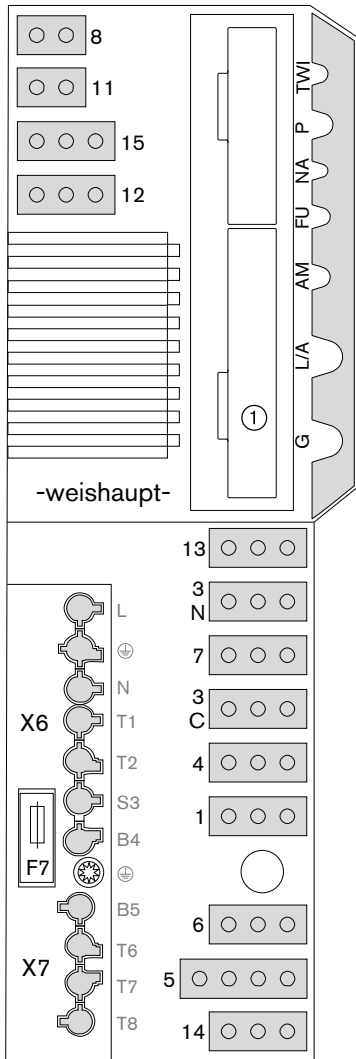

TWI	TWI interface (Vision Box)
P	free
NA	free
FC	free
AM	Digital/analogue converter (DAU01)
L/A	Air damper actuator
G	Coded plug (yellow)
①	Slot analogue module EM3/3 or Fieldbus module EM3/2
1	External liquid petroleum gas valve
3C	Digital/analogue converter (DAU01)
3N	Frequency converter
4	Ignition unit
5	Double gas valve and air pressure switch burner operation
6	free
7	Low gas pressure switch
8	Gas meter (impulse generator)
11	Air pressure switch pre-purge
12	Valve proving gas pressure switch
13	Ionisation
14	Remote reset (plug cable No. 14 required)
15	Bridging plug No. 15 or high gas pressure switch
X6	7 pole connection plug
X7	4 pole connection plug
F7	Internal unit fuse (6.3 AT)



If a digital load converter (DLU) is used, this has to be replaced with the analogue module EM3/3.



**3 Product description**

**3.1.4 Dual fuel burner**

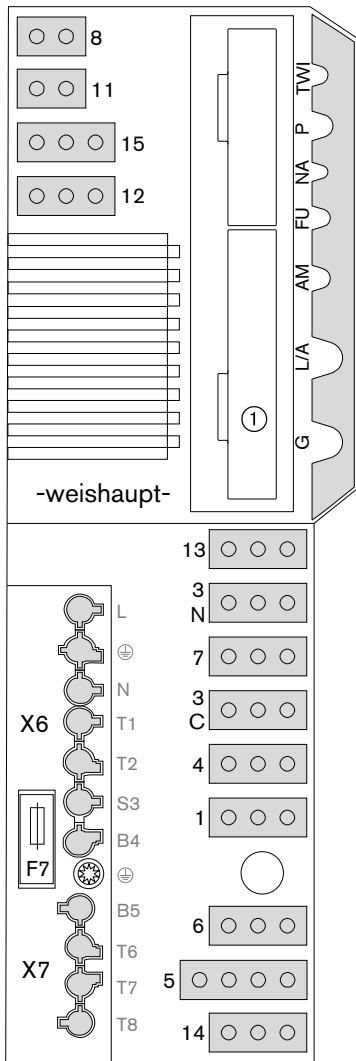

- |     |   |
|-----|---|
| TWI | TWI interface (Vision Box)                                      |
| P   | free  |
| NA  | free  |
| FC  | free  |
| AM  | Operating panel of remote reset                                 |
| L/A | Air damper actuator   |
| G   | Gas butterfly valve actuator                                    |
| ①   | Slot analogue module EM3/3 or Fieldbus module EM3/2             |
| 1   | Stage 1 solenoid valve (Y11)                                    |
| 3C  | Pump motor and safety solenoid valve Oil (Y14)                  |
| 3N  | Burner motor and external LPG valve                             |
| 4   | Ignition unit   |
| 5   | Multifunction assembly or double gas valve                      |
| 6   | Stage 2 solenoid valve (Y12)                                    |
| 7   | Bridging plug No. 7   |
| 8   | Fuel change-over  |
| 11  | Air pressure switch   |
| 12  | Low / valve proving gas pressure switch and oil pressure switch |
| 13  | Flame sensor  |
| 14  | Remote reset (plug cable No. 14 required)                       |
| 15  | Bridging plug No. 15 or high gas pressure switch                |
| X6  | 7 pole connection plug  |
| X7  | 4 pole connection plug  |
| F7  | Internal unit fuse (6.3 AT)                                     |



If a digital load converter (DLU) is used, this has to be replaced with the analogue module EM3/3.

### 3 Product description

### 3.2 Technical data

#### 3.2.1 Electrical data

Mains voltage/frequency	230 V / 50 ... 60 Hz
Consumption	max 12 W
Internal unit fuse	6.3 A slow
Type of protection	IP 40

#### 3.2.2 Ambient conditions

Temperature in operation	-20 ... +60 °C
Temperature during transport / storage	-20 ... +70 °C
Relative humidity	DIN 60730-1, no dew point

#### 3.2.3 Dimensions

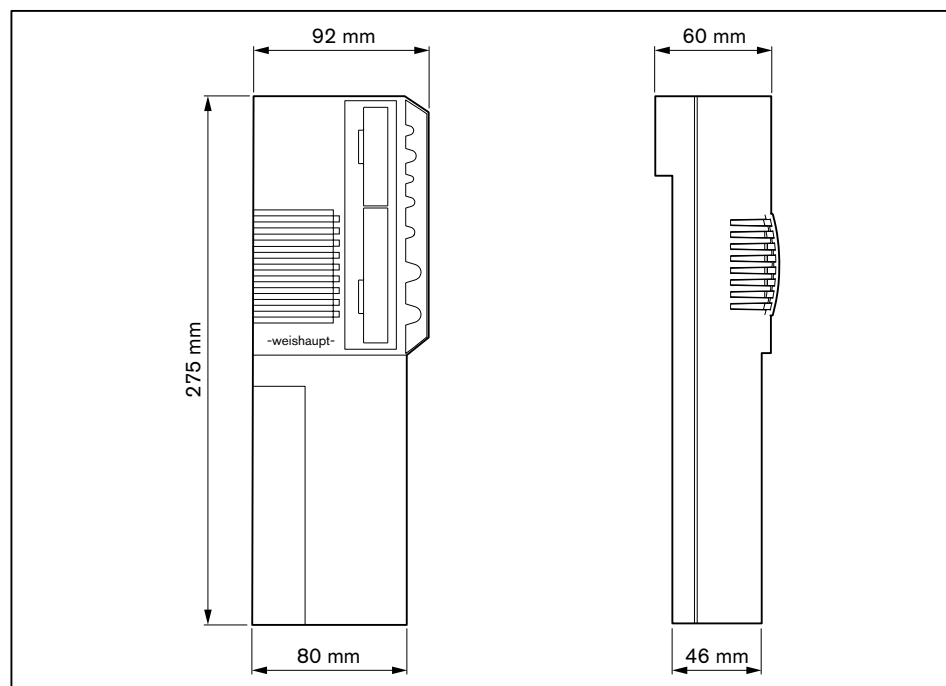

4 Operation

4 Operation

4.1 Operating panel

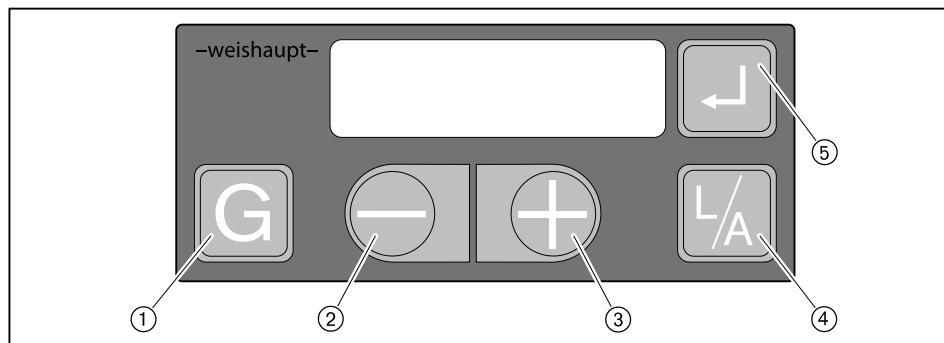

No.	Key	Function
①	[G] Gas	Select gas butterfly valve actuator or speed control
②	[-]	Change values
③	[+]	
④	[L/A] Air	Select air damper actuator
⑤	[ENTER]	Reset burner; call up information press approx. 0.5 seconds = Info level press approx. 2 seconds = Service level
③ and ⑤	[+] and [ENTER]	press approx. 2 seconds = Parameter level (only possible with display OFF)



Various actions (e. g. changing the display, reset) are only triggered when the key is released.

**Operating level**

The current actuator position or the fan speed can be displayed by pressing keys in operating level (10).

Displaying air damper setting:

- ▶ Press key [L/A].

Displaying gas butterfly valve setting or fan speed:

- ▶ Press key [G].

**Off function**

- ▶ Press keys [ENTER], [L/A] and [G] simultaneously.
- ✓ Immediate lockout with error 18h.

## 4 Operation

### Operating phase

The exact operating phase of the combustion manager can also be displayed. This simplifies determining the cause of the fault during troubleshooting (see Ch. 9.1).

The display can be called up in Standby (OFF).

- ▶ Press and hold keys [+] and [-] simultaneously for approx. 3 seconds.
- ✓ The combustion manager changes to operating display. In the display, the current operating phase is shown with a number.

Switching back to standard display:

- ▶ Press and hold keys [+] and [-] simultaneously for approx. 3 seconds.

4 Operation

4.2 Display

Operating panel

The display shows the current operating status and operating data.

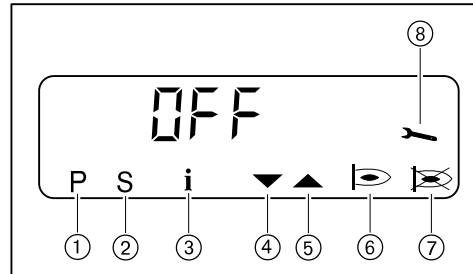

- ① Setting level activated
- ② Start phase activated
- ③ Info level activated
- ④ Actuator runs CLOSED
- ⑤ Actuator runs OPEN
- ⑥ Burner in operation
- ⑦ Lockout
- ⑧ Service level activated

OFF	No heat demand
OFF GAS	No heat demand (fuel selected: Gas)
OFF OIL	No heat demand (fuel selected: Oil)
OFF S	Shutdown via contact X3:7 (plug No. 7)
OFF UP r	Programming not completed
UP r GAS	Programming of gas part not completed
UP r OIL	Programming of oil part not completed
OFF E	Switch off via Fieldbus
OFF Gd	Insufficient gas low gas pressure switch
F1	Low voltage (display flashes)
F9	Connection to Fieldbus faulty (display flashes)



**4 Operation**

**4.2.1 Info level**

**Gas burner / gas burner with speed control**

Burner data can be interrogated in the Info level.

- ▶ Press [Enter] key approx. 0.5 seconds.
- ✓ The Info level is activated.
- ▶ Press [Enter] to reach the next information.

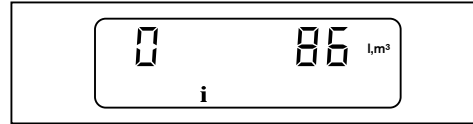

No.	Information
0	Total gas consumption in m <sup>3</sup> (via X3:8) Reset value: ▶ Press [L/A] and [+] keys simultaneously for ca. 2 secs.
1	Operating hours
2	- no function -
3	Burner starts
4	Device item number
5	Index of device item number
6	Unit number
7	Production date (DDMMYY)
8	Fieldbus address
9	Valve proving behaviour
11	- no function -
12	Current gas consumption (0.1 m <sup>3</sup> /h)
13	Analogue module EM3/3 or Fieldbus module EM3/2 available 0 = No 1 = Yes

After information 13 or a waiting time of approx. 20 seconds the combustion manager changes over to the operating level.

**4 Operation**

**Oil burner**

Burner data can be interrogated in the Info level.

- ▶ Press [Enter] key approx. 0.5 seconds.
- ✓ The Info level is activated.
- ▶ Press [Enter] to reach the next information.



No.	Information
0	Total oil consumption in litres (via X3:8) Reset value: ▶ Press [L/A] and [+] keys simultaneously for ca. 2 secs.
1	Operating hours stage 1
2	Operating hours stage 2
3	Burner starts
4	Device item number
5	Index of device item number
6	Unit number
7	Production date (DDMMYY)
8	Fieldbus address
10	Oil pressure switch function
11	- no function -
12	Current oil consumption (0.1 l/h)
13	Analogue module EM3/3 or Fieldbus module EM3/2 available 0 = No 1 = Yes

After information 13 or a waiting time of approx. 20 seconds the combustion manager changes over to the operating level.

**4 Operation**

**Dual fuel burner**

Burner data can be interrogated in the Info level.

- ▶ Press [Enter] key approx. 0.5 seconds.
- ✓ The Info level is activated.
- ▶ Press [Enter] to reach the next information.



No.	Information
0	- no function -
1	Operating hours in gas operation or oil operation stage 1
2	Operating hours in oil operation stage 2
3	Total burner starts
4	Device item number
5	Index of device item number
6	Unit number
7	Production date (DDMMYY)
8	Fieldbus address
9	Valve proving behaviour
10	Oil pressure switch function
11	- no function -
12	- no function -
13	Analogue module EM3/3 or Fieldbus module EM3/2 available 0 = No 1 = Yes

After information 13 or a waiting time of approx. 20 seconds the combustion manager changes over to the operating level.

**4 Operation**

**4.2.2 Service level**

**Gas burner / dual fuel burner (Gas operation)**

The service level gives information about:

- Actuator position of individual operating points
- The most recent fault
- Flame signal during operation.

▶ Press [ENTER] key for approx. 2 seconds.

✓ The service level is activated.

▶ Press [Enter] to reach the next information.

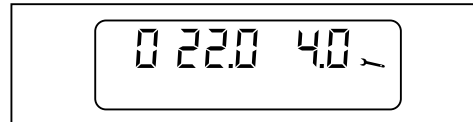

No.	Information
0	Actuator position in operating point P0
1	Actuator position in operating point P1
2	Actuator position in operating point P2
3	Actuator position in operating point P3
4	Actuator position in operating point P4
5	Actuator position in operating point P5
6	Actuator position in operating point P6
7	Actuator position in operating point P7
8	Actuator position in operating point P8
9	Actuator position in operating point P9
10 ... 18	most recent fault ... ninth last occurred fault Display additional information: 1. Detailed fault code / operating phase ▶ Press [+] key. 2. Detailed fault code ▶ Press keys [+] and [-] simultaneously. 3. Detailed fault code ▶ Press key [L/A]. Repetition counter ▶ Press key [G].
19	Flame signal: 00 = no flame ... 58 = high intensity

After information 19 or a waiting time of approx. 20 seconds the combustion manager changes over to the operating level.

**4 Operation**

**Gas burner with speed control**

The service level gives information about:

- Actuator position of individual operating points
- The most recent fault
- Flame signal during operation.

- ▶ Press [ENTER] key for approx. 2 seconds.
- ✓ The service level is activated.
- ▶ Press [Enter] to reach the next information.

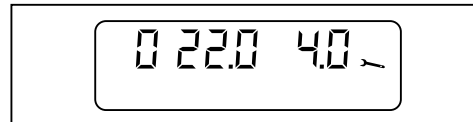

No.	Information
0	Fan speed and air damper setting in operating point P0
1	Fan speed and air damper setting in operating point P1
9	Fan speed and air damper setting in operating point P9
10 ... 18	most recent fault ... ninth last occurred fault  Display additional information:  1. Detailed fault code / operating phase ▶ Press [+] key.  2. Detailed fault code ▶ Press keys [+] and [-] simultaneously.  3. Detailed fault code ▶ Press key [L/A].  Repetition counter ▶ Press key [G].
19	Flame signal: 00 = no flame ... 58 = high intensity

After information 19 or a waiting time of approx. 20 seconds the combustion manager changes over to the operating level.

**4 Operation**

**Oil burner / dual fuel burner (oil operation)**

The service level gives information about:

- Actuator position of individual operating points
  - The most recent fault
  - Flame signal during operation.
- ▶ Press [ENTER] key for approx. 2 seconds.  
 ✓ The service level is activated.  
 ▶ Press [Enter] to reach the next information.

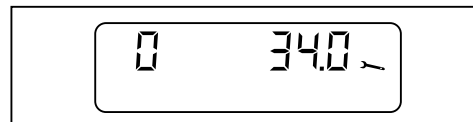

No.	Information
0	Actuator position in operating point P <sup>0</sup>
1	Actuator position in operating point P <sup>1</sup>
2	Actuator position in operating point P <sup>2</sup> (switch off point stage 2 when running closed)
3	Actuator position in operating point P <sup>3</sup> (switch on point stage 2 when running open)
9	Actuator position in operating point P <sup>9</sup>
10 ... 18	most recent fault ... ninth last occurred fault Display additional information: 1. Detailed fault code / operating phase ▶ Press [+] key. 2. Detailed fault code ▶ Press keys [+] and [-] simultaneously. 3. Detailed fault code ▶ Press key [L/A]. Repetition counter ▶ Press key [G].
19	Flame signal Oil burner: 255 ... 121 = no flame ... 1 = high intensity Dual fuel burner: 00 = no flame ... 58 = high intensity

After information 1<sup>9</sup> or a waiting time of approx. 20 seconds the combustion manager changes over to the operating level.

## 4 Operation

### 4.2.3 Parameter level

#### Gas burner

The parameter level can only be called up in Standby (OFF) mode.

- ▶ Press [+] and [Enter] keys simultaneously for approx. 2 seconds.
- ✓ The parameter level is activated.



- ▶ Press [+].
- ▶ Press [Enter] to reach the next information.

Pno.	Information	Range of values	Factory setting
1	Fieldbus address	0 ... 254 / OFF Switch over to OFF and to address: ▶ Briefly press [+] and [-] keys simultaneously.	OFF
2	Actuator position in Standby	0.0 ... 90.0° Adjust air damper setting: ▶ Press [L/A] and [+] keys or press [-] key. Adjusting gas butterfly valve setting: ▶ Press [G] and [+] keys or press [-] key.	0.0
4	Post-purge time	0 ... 4095 s	2
5	Fault history	0 = Fault memory is empty 1 = Fault memory contains data Delete fault memory: ▶ Press [L/A] and [+] keys simultaneously for ca. 2 secs.	-
6	Factor for gas consumption Impulse rate of meter per m <sup>3</sup>	1 ... 65535 200 impulses ± 1 m <sup>3</sup> ▶ Adjust factor depending on impulse rate of gas meter	200
A	Low / valve proving gas pressure switch (X3:12)	0 = not activated 1 = Proof-of-closure (valve 1) 2 = without low gas pressure switch 3 = with low gas pressure switch	3
b	Air pressure switch (X3:11) (display only, no adjustment possible)	0 = not activated 1 = activated	1
C	Operating mode output X3:1	0 = not activated 1 = with pilot valve not interrupted 2 = with pilot valve interrupted 3 = Standard (external LPG valve)	3
d	Flame sensor	0 = Ionisation electrode / flame sensor FLW 1 = switch input (X3:14) 2 = flame sensor QRB	0
E	Display mode	On = Parameter E0 ... E4 not activated in setting mode OFF = Parameter E0 ... E4 activated in setting mode	On <sup>(1)</sup>
F	Restart attempts following flame failure	0 ... 1	1

<sup>(1)</sup> Following commissioning, set parameter E to OFF.

After parameter F or a waiting time of approx. 20 seconds the combustion manager changes over to the operating level.

#### 4 Operation

##### Gas burner with speed control

The parameter level can only be called up in Standby (OFF) mode.

- ▶ Press [+] and [Enter] keys simultaneously for approx. 2 seconds.
- ✓ The parameter level is activated.



- ▶ Press [+].
- ▶ Press [Enter] to reach the next information.

Pno.	Information	Range of values	Factory setting
1	Fieldbus address	0 ... 254 / OFF Switch over to OFF and to address: ▶ Briefly press [+] and [-] keys simultaneously.	OFF
2	Actuator position in Standby	0.0 ... 90.0° Adjust air damper setting: ▶ Press [L/A] and [+] keys or press [-] key. Changing the fan speed: ▶ Press [G] and [+] keys or press [-] key.	0.0
4	Post-purge time	0 ... 4095 s	2
5	Fault history	0 = Fault memory is empty 1 = Fault memory contains data Delete fault memory: ▶ Press [L/A] and [+] keys simultaneously for ca. 2 secs.	-
6	Factor for gas consumption Impulse rate of meter per m <sup>3</sup>	1 ... 65535 200 impulses ± 1 m <sup>3</sup> ▶ Adjust factor depending on impulse rate of gas meter	200
A	Low / valve proving gas pressure switch (X3:12)	0 = not activated 1 = Proof-of-closure (valve 1) 2 = without low gas pressure switch 3 = with low gas pressure switch	3 <sup>(1)</sup>
b	Air pressure switch (X3:11) (display only, no adjustment possible)	0 = not activated 1 = activated	1
C	Operating mode output X3:1	0 = not activated 1 = with pilot valve not interrupted 2 = with pilot valve interrupted 3 = Standard (external LPG valve)	3
d	Flame sensor	0 = Ionisation electrode / flame sensor FLW 1 = switch input (X3:14) 2 = flame sensor QRB	0
E	Display mode	On = Parameter E0 ... E4 not activated in setting mode OFF = Parameter E0 ... E4 activated in setting mode	On <sup>(2)</sup>
F	Restart attempts following flame failure	0 ... 1	1

<sup>(1)</sup> On gas burners with speed control, parameter A must be set to 2.

<sup>(2)</sup> Following commissioning, set parameter E to OFF.

After parameter F or a waiting time of approx. 20 seconds the combustion manager changes over to the operating level.



#### 4 Operation

##### Oil burner

The parameter level can only be called up in Standby (OFF) mode.

- ▶ Press [+] and [Enter] keys simultaneously for approx. 2 seconds.
- ✓ The parameter level is activated.



- ▶ Press [+].
- ▶ Press [Enter] to reach the next information.

Pno.	Information	Range of values	Factory setting
1	Fieldbus address	0 ... 254 / OFF Switch over to OFF and to address: ▶ Briefly press [+] and [-] keys simultaneously.	OFF
2	Actuator position in Standby	0.0 ... 90.0° Adjust air damper setting: ▶ Press [L/A] and [+] keys or press [-] key.	0.0
4	Post-purge time	0 ... 4095 s	2
5	Fault history	0 = Fault memory is empty 1 = Fault memory contains data Delete fault memory: ▶ Press [L/A] and [+] keys simultaneously for ca. 2 secs.	-
6	Factor for oil consumption Impulse rate of meter per litre	1 ... 65535 200 impulses ± 1 litre ▶ Adjust factor depending on impulse rate of oil meter	200
7	Oil pressure switch (X3:12)	0 = not activated 1 = activated	0 <sup>(1)</sup>
8	Air pressure switch (X3:11)	0 = not activated 1 = activated	0 <sup>(2)</sup>
9	Operating mode output X3:1	1 = safety solenoid valve 2 = tank valve	1
d	Flame sensor	0 = Ionisation electrode / flame sensor FLW 1 = switch input (X3:14) 2 = flame sensor QRB	2
E	Display mode	On = Parameter E0 ... E4 not activated in setting mode OFF = Parameter E0 ... E4 activated in setting mode	On <sup>(3)</sup>
F	Restart attempts following flame failure	0 ... 1	1

<sup>(1)</sup> If an oil pressure switch is fitted, set parameter 7 and parameter 8 to 1.

<sup>(2)</sup> If an air pressure switch is fitted, set parameter 8 to 1.

<sup>(3)</sup> Following commissioning set parameter E to OFF.

After parameter F or a waiting time of approx. 20 seconds the combustion manager changes over to the operating level.

#### 4 Operation

##### Dual fuel burner

The parameter level can only be called up in Standby (OFF) mode.

- ▶ Press [+] and [Enter] keys simultaneously for approx. 2 seconds.
- ✓ The parameter level is activated.



- ▶ Press [+].
- ▶ Press [Enter] to reach the next information.

Pno.	Information	Range of values	Factory setting
1	Fieldbus address	0 ... 254 / OFF Switch over to OFF and to address: ▶ Briefly press [+] and [-] keys simultaneously.	OFF
2	Actuator position in Standby	0.0 ... 90.0° Adjust air damper setting: ▶ Press [L/A] and [+] keys or press [-] key. Adjusting gas butterfly valve setting: ▶ Press [G] and [+] keys or press [-] key.	0.0
4	Post-purge time	0 ... 4095 s	2
5	Fault history	0 = Fault memory is empty 1 = Fault memory contains data Delete fault memory: ▶ Press [L/A] and [+] keys simultaneously for ca. 2 secs.	-
6	- no function -	-	-
7	Oil pressure switch (X3:12)	0 = not activated 1 = activated	0 <sup>(1)</sup>
8	Air pressure switch for oil operation (X3:11)	0 = not activated 1 = activated	0 <sup>(1)</sup>
9	Operating mode output X3:1 for oil operation	1 = safety solenoid valve 2 = tank valve	1
A	Low / valve proving gas pressure switch (X3:12)	0 = not activated 1 = Proof-of-closure (valve 1) 2 = without low gas pressure switch 3 = with low gas pressure switch	3
b	Air pressure switch for gas operation (X3:11) (display only, no adjustment possible)	0 = not activated 1 = activated	1
C	Operating mode output X3:1 for gas operation	0 = not activated 1 = with pilot valve not interrupted 2 = with pilot valve interrupted 3 = Standard (external LPG valve)	3

<sup>(1)</sup> Set parameter to 1 prior to commissioning.

**4 Operation**

Pno.	Information	Range of values	Factory setting
d	Flame sensor	0 = Ionisation electrode / flame sensor FLW 1 = switch input (X3:14) 2 = flame sensor QRB	0
E	Display mode	On = Parameter E0 ... E4 not activated in setting mode OFF = Parameter E0 ... E4 activated in setting mode	On <sup>(2)</sup>
F	Restart attempts following flame failure	0 ... 1	1

<sup>(2)</sup> Following commissioning, set parameter E to OFF.

After parameter F or a waiting time of approx. 20 seconds the combustion manager changes over to the operating level.

**4 Operation**

**4.2.4 Access level**

The configuration can be adapted relative to the burner type or version in the access level.

In the parameter level, the display mode must be set to On to enable access to parameters E0 ... E4.

- ▶ Press [G] and [L/A] simultaneously.
- ✓ The access level is activated.



- ▶ Press [+].
- ▶ Set the required value using [ENTER] and [+] or [-] keys.
- ▶ Press [+] key to reach the next information.

Parameters	Information	Range of values
E0	Burner type	0 = Single fuel burner 1 = Dual fuel burner
E1	Type of operation (display only, no adjustment possible)	0 = intermittent operation 1 = continuous operation
E2	Flame sensor type	0 = Ionisation electrode / flame sensor FLW 1 = switch input (X3:14) 2 = flame sensor QRB
E3	Fan configuration	0 = Off 1 = Fan control 2 = Fan control with fan monitoring 3 = Speed control 4 = Fan control according to modulation degree specified 5 = DAU control 6 ... 255 = Off
E4	Pre-ignition for oil burner	0 ... 4094 seconds (the time runs down from operating phase No. 09, then ignition is started) OFF = Ignition only from operating phase No. 15

## 4 Operation

### 4.3 Linearisation

During commissioning it is possible to carry out linearisation of the operating points for gas burners or for gas operation.

During linearisation a straight line is generated from the operating point displayed to P9. The values on the straight are adopted as the new operating points.

Initiate a calculation after P9:

▶ Press [ENTER] key.

✓ Combustion manager changes to linearisation mode.

The linearisation mode can be interrupted using the [-] key.

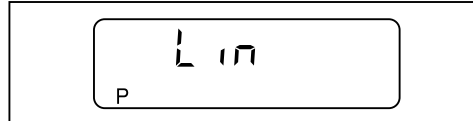

▶ Confirm with [+] key.

✓ Linearisation is initiated.

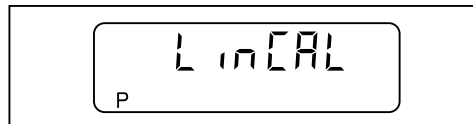

#### Example:

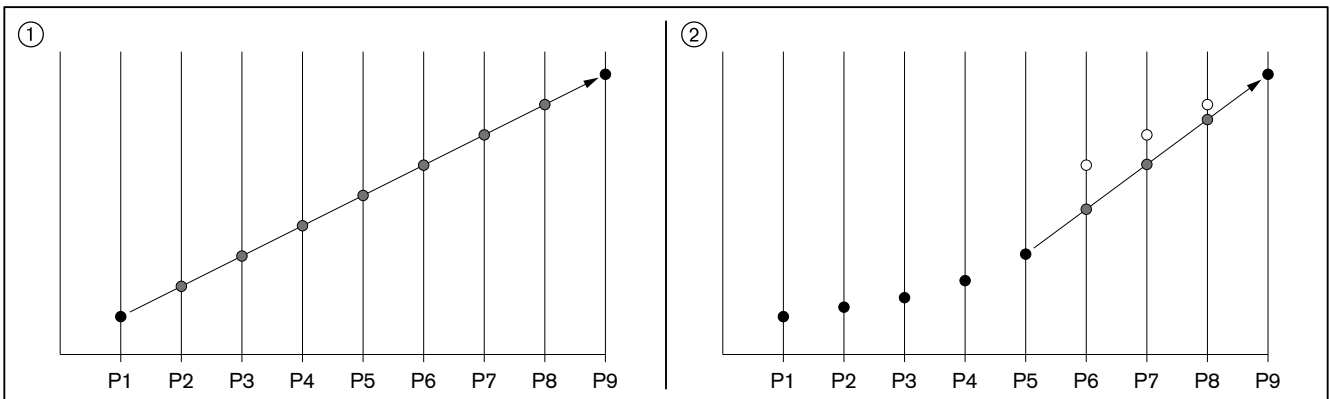

① Calculation from P1 to P9

② Calculation from P5 to P9

## 5 Installation

### 5 Installation

#### 5.1 Replacing the combustion manager



##### Risk of electric shock

Working on the unit when voltage is applied can lead to electric shock.

- ▶ Isolate the unit from the power supply prior to starting any work.
- ▶ Safeguard against accidental re-start.

The conversion must only be carried out by qualified electricians. Observe local regulations.

##### Removing W-FM 20 ... 24

- ▶ Unplug all plugs.
- ▶ Undo screws ①.
- ▶ Push combustion manager upwards and remove.

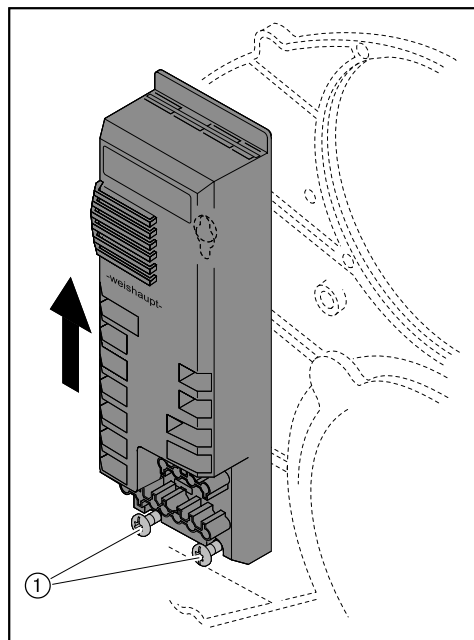

## 5 Installation

### Fitting W-FM 25



On sizes W30 and W40, the burner motor should be fed via contactor (except when using variable speed drive).

If the boiler control is protected by an internal 10 A fuse, the plug cable for separate motor power supply can be used. This means it is not necessary to install a separate voltage supply for the motor.

Pre-fusing of separate supply line:

- min 10 AT
- max 16 AT

- ▶ Observe inputs and outputs of combustion manager W-FM 25 (see Ch. 3.1).
- ▶ If required, remove contactor and snap it on to the carrier rail ① of the bracket supplied.
- ▶ If required, fit bracket ② supplied.
- ▶ Fit combustion manager.
- ▶ Plug in all plugs, if necessary use extension cable No. 4.
- ▶ On gas and dual fuel burners, plug in bridging plug No. 15 supplied (see Ch. 3.1).
- ▶ If necessary, connect supply line for burner motor or plug cable for motor voltage supply to the connection plug of the contactor.

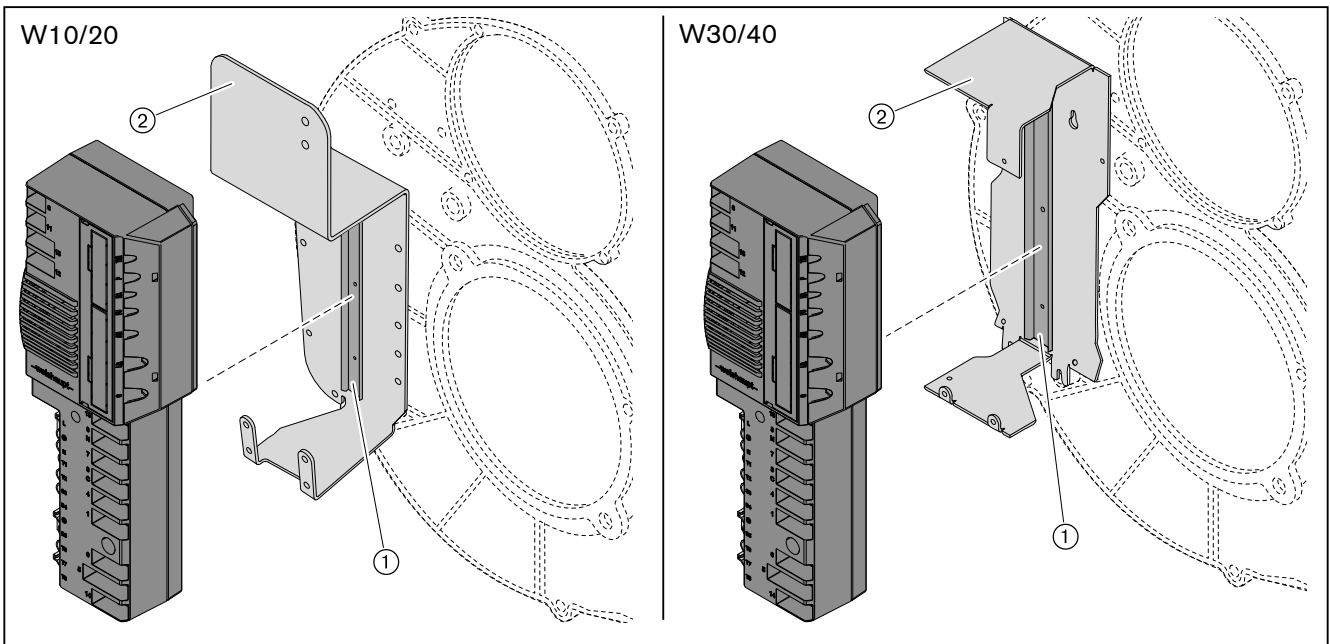

## 6 Commissioning

### 6 Commissioning

In addition to this chapter, the installation and operating manual of the burner should be observed.

#### 6.1 Gas burner

##### 1. Preset combustion manager

- ▶ Unplug bridging plug No. 7 on combustion manager.
- ▶ Switch on voltage supply.
- ✓ The unprogrammed condition of the combustion manager is indicated by a flashing display.  
 The burner goes to lockout.

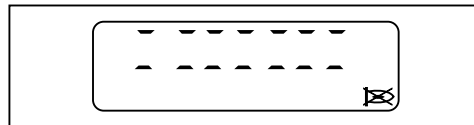

- ▶ Press [ENTER] key.
- ✓ Burner has been reset.
- ✓ Combustion manager drives to Standby.



- ▶ Press [G] and [L/A] simultaneously.
- ✓ Combustion manager changes to access level.

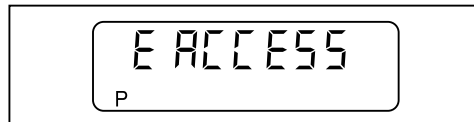

- ▶ Press [+].
- ✓ Setting level (parameter E0) is displayed.

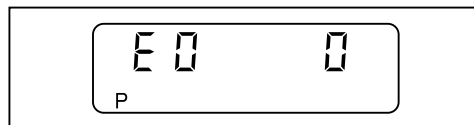

- ▶ Adopt value 0 (single fuel burner), if necessary adjust using [ENTER] and [-] key.
- ▶ Press [+].
- ✓ E1 is displayed.

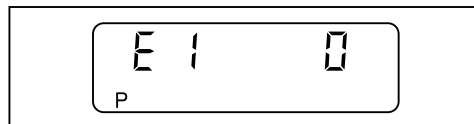

The value of parameter E1 can not be altered.

- 0 = intermittent operation (Standard)
- 1 = continuous operation (if W-FM 21 was used previously)



## 6 Commissioning

- ▶ Press [+].
- ✓ E2 is displayed.

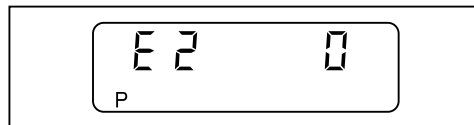

- ▶ Adopt value 0 (ionisation electrode), if necessary adjust using [ENTER] and [-] key.
- ▶ Press [+].
- ✓ E3 is displayed.

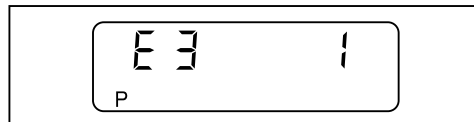

- ▶ Adopt value 1 (fan control), if necessary set using [ENTER] and [-] or [+] key.
- ▶ Press [+].
- ✓ Combustion manager changes into the setting level for step points.

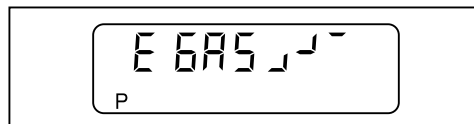

- ▶ Determine the air damper and gas butterfly valve setting for operating points P0, P1 and P9 from the sticker for burner setting.

The operating points are preset using these values:

- ▶ Press [+].
- ✓ Factory setting operating point P9 (Full load) is displayed.



- ▶ Press and hold [L/A] and set air damper setting using the [-] or [+] key.
- ▶ Press and hold [G] and set gas butterfly valve setting using the [-] or [+] key.
- ▶ Press [+].
- ✓ Factory setting operating point P1 (partial load) is displayed.



- ▶ Press and hold [L/A] and set air damper setting using the [-] or [+] key.
- ▶ Press and hold [G] and set gas butterfly valve setting using the [-] or [+] key.

## 6 Commissioning

- ▶ Press [+].
- ✓ Factory setting operating point P0 (ignition load) is displayed.



- ▶ Press and hold [L/A] and set air damper setting using the [-] or [+] key.
- ▶ Press and hold [G] and set gas butterfly valve setting using the [-] or [+] key.
- ▶ Press [+].
- ✓ Combustion manager is preset.

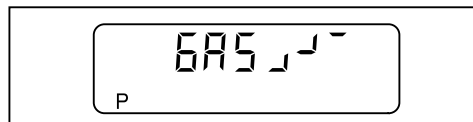

### 2. Check sequence of operation

- ▶ Open gas isolating valve.
- ✓ Gas pressure in gas valve train increases.
- ▶ Close isolating valve.
- ▶ Plug in bridging plug No. 7 on combustion manager.
- ✓ Burner starts.
- ▶ Check sequence of operation:
  - Valves open.
  - Gas pressure switch reacts.
  - Burner start is interrupted.
  - Low gas program starts.

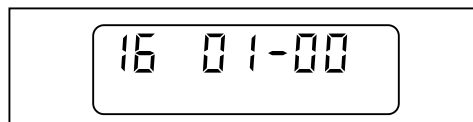

- ▶ Unplug 7 pole connection plug and plug it in again.
- ✓ Low gas program is interrupted.



### 3. Adjusting the operating points



If a controlled shutdown or lockout occurs during setting:

- ▶ Press [-] and [+] simultaneously.
- ▶ Then press [+] key.
- ✓ Combustion manager changes to setting level.

- ▶ Open gas isolating valve.
- ▶ Press [-] and [+] simultaneously.
- ✓ The display shows E ACCESS.



## 6 Commissioning

- ▶ Press [+].
- ✓ Burner starts according to the sequence of operation and stops at operating point P<sup>0</sup> (ignition load).

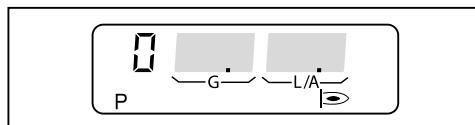

- ▶ Check combustion and if necessary adjust via air damper or gas butterfly setting.
- ▶ Press [+].
- ✓ Burner drives to P1.

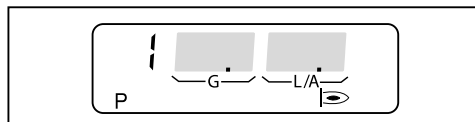

- ▶ Check combustion and if necessary adjust via air damper or gas butterfly setting.
- ▶ Press [+].
- ✓ Burner drives to P2.
- ▶ Determine the air damper and gas butterfly valve setting for operating point P2.
- ▶ Preset P2 with these values.
- ▶ Check combustion and if necessary adjust via air damper or gas butterfly setting.
- ▶ Repeat steps for each operating point until P<sup>9</sup> has been reached.



### 4. Adjust full load

- ▶ Press [G] and [L/A] simultaneously.
- ✓ Burner drives to full load.
- ✓ The upper operating limit (bo) is displayed.

If necessary, full load can be adjusted using [-] or [+] keys.

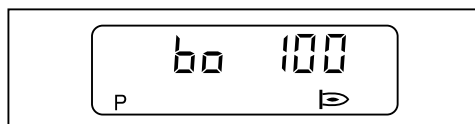

## 6 Commissioning

### 5. Adjust partial load

- ▶ Press [G] and [L/A] simultaneously.
- ✓ Burner drives to partial load.
- ✓ The lower operating limit is displayed (bu).

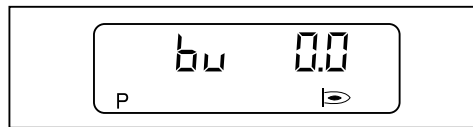

The value bu is given in percent on the W-FM 25, on the W-FM 20 ... 24 bu corresponds with the air damper setting.

- ▶ Determine gas throughput for partial load from test sheet.
- ▶ Set bu using [-] or [+] key.
- ▶ Determine gas throughput and adjust value.
- ▶ Press [G] and [L/A] simultaneously.
- ✓ Combustion manager changes to operating level (10).
- ✓ Combustion manager is programmed.



### 6. Check start behaviour

- ▶ Switch off and restart burner.
- ▶ Check start behaviour and if necessary correct ignition load (P0).

If the ignition load set has been changed:

- ▶ Re-check start behaviour.

### 7. Deactivate E-Parameters

Burner must be in Standby (OFF).

- ▶ Press [Enter] and [+] keys simultaneously for approx. 2 seconds.
- ✓ The parameter level is activated.
- ▶ Press [+].
- ▶ Press [Enter] key until parameter E is displayed.
- ▶ Set parameter E to OFF.
- ✓ E-Parameters are not shown in the setting level.
- ▶ Press [Enter] key twice.
- ✓ Combustion manager returns to the operating level.

## 6 Commissioning

### 6.2 Gas burner with speed control

#### 1. Preset combustion manager

- ▶ Unplug plug No. 7 from combustion manager.
- ▶ Switch on voltage supply.
- ✓ The unprogrammed condition of the combustion manager is indicated by a flashing display.  
The burner goes to lockout.

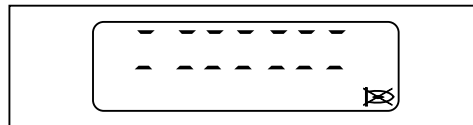

- ▶ Press [ENTER] key.
- ✓ Burner has been reset.
- ✓ Combustion manager drives to Standby.



Parameter A must be set to value 2.

- ▶ Press [Enter] and [+] keys simultaneously for approx. 2 seconds.
- ✓ The parameter level is activated.
- ▶ Press [+].
- ▶ Press [Enter] key until parameter A is displayed.
- ▶ Set parameter A to value 2 (without low gas pressure switch).
- ▶ Press [Enter] key until parameter OFFUPr is displayed again.
- ▶ Press [G] and [L/A] simultaneously.
- ✓ Combustion manager changes to access level.



- ▶ Press [+].
- ✓ Setting level (parameter E0) is displayed.

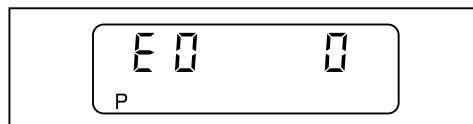

- ▶ Adopt value 0 (single fuel burner), if necessary adjust using [ENTER] and [-] key.

## 6 Commissioning

- ▶ Press [+].
- ✓ E1 is displayed.

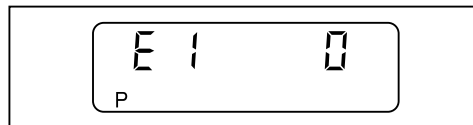

The value of parameter E1 can not be altered.

- 0 = intermittent operation (Standard)
- 1 = continuous operation (only if W-FM 21 was used previously)

- ▶ Press [+].
- ✓ E2 is displayed.

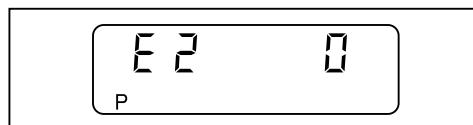

- ▶ Adopt value 0 (ionisation electrode), if necessary adjust using [ENTER] and [-] key.

- ▶ Press [+].
- ✓ E3 is displayed.

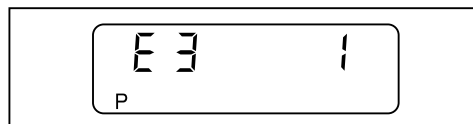

- ▶ Adopt value 1 (fan control), if necessary set using [ENTER] and [-] or [+] key.

- ▶ Press [+].
- ✓ Combustion manager changes into the setting level for step points.



- ▶ Determine the air damper setting and fan speed for operating points P0, P1 and P9 from the sticker for burner setting.

The operating points are preset using these values:

- ▶ Press [+].
- ✓ Factory setting operating point P9 (Full load) is displayed.



- ▶ Press and hold [L/A] and set air damper setting using the [-] or [+] key.
- ▶ Press and hold [G] and set fan speed using [-] or [+] key.

## 6 Commissioning

- ▶ Press [+].
- ✓ Factory setting operating point P1 (partial load) is displayed.



- ▶ Press and hold [L/A] and set air damper setting using the [-] or [+] key.
- ▶ Press and hold [G] and set fan speed using [-] or [+] key.
- ▶ Press [+].
- ✓ Factory setting operating point P0 (ignition load) is displayed.



- ▶ Press and hold [L/A] and set air damper setting using the [-] or [+] key.
- ▶ Press and hold [G] and set fan speed using [-] or [+] key.
- ▶ Press [+].
- ✓ Combustion manager is preset.

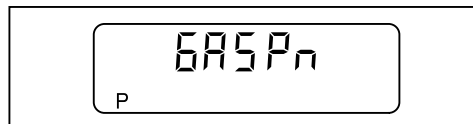

- ▶ Unplug 7 pole connection plug and plug it in again.
- ✓ Low gas program is interrupted.

### 2. Check sequence of operation

- ▶ Open gas isolating valve.
- ✓ Gas pressure in gas valve train increases.
- ▶ Close isolating valve.
- ▶ Plug in plug No. 7 on combustion manager.
- ✓ Burner starts.
- ▶ Check sequence of operation:
  - Valves open.
  - Gas pressure switch reacts.
  - Burner start is interrupted.



- ▶ Unplug 7 pole connection plug and plug it in again.



## 6 Commissioning

### 3. Adjusting the operating points



If a controlled shutdown or lockout occurs during setting:

- ▶ Press [G] and [L/A] simultaneously.
- ▶ Then press [+] key.
- ✓ Combustion manager changes to setting level.

- ▶ Open gas isolating valve.
- ▶ Press [-] and [+] simultaneously.
- ✓ The display shows E ACCESS.



- ▶ Press [+].
- ✓ Burner starts according to the sequence of operation and stops at operating point P<sup>0</sup> (ignition load).

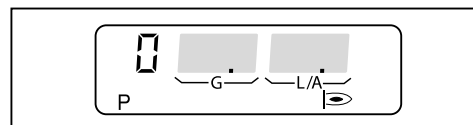

- ▶ Press [+].
- ✓ Burner drives to P1.

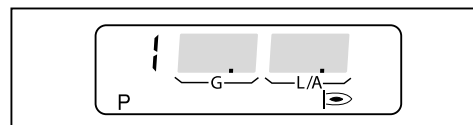

- ▶ Check combustion and if necessary adjust combustion values via N-correction on the double solenoid valve.
- ▶ Press [+].
- ✓ Burner drives to P2.
- ▶ Press [+] key until P<sup>9</sup> is reached whilst checking combustion at each point and adjust via V-correction on double solenoid valve.



- ▶ Press [-].
- ✓ Burner drives to P8.
- ▶ Press [-] until P1 is reached.

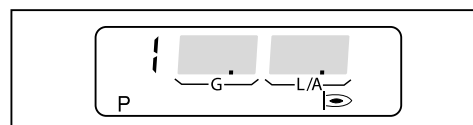

- ▶ Check combustion and if necessary adjust combustion values via N-correction on the double solenoid valve.



## 6 Commissioning

### 4. Adjust full load

- ▶ Press [+] key until P<sup>9</sup> is reached whilst checking combustion at each point.
- ▶ Press [G] and [L/A] simultaneously.
- ✓ Burner drives to full load.
- ✓ The upper operating limit (bo) is displayed.

If necessary, full load can be adjusted using [-] or [+] keys.

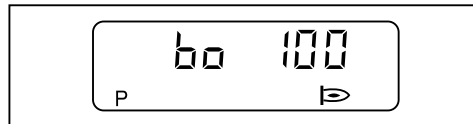

### 5. Adjust partial load

- ▶ Press [G] and [L/A] simultaneously.
- ✓ Burner drives to partial load.
- ✓ The lower operating limit is displayed (bu).

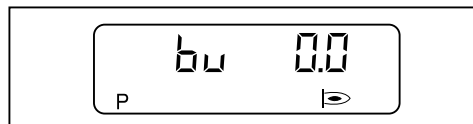

If necessary, partial load can be adjusted using [-] or [+] keys.

- ▶ Press [G] and [L/A] simultaneously.
- ✓ Combustion manager changes to operating level (10).
- ✓ Combustion manager is programmed.



### 6. Check start behaviour

- ▶ Switch off and restart burner.
- ▶ Check start behaviour and if necessary correct ignition load (P<sup>0</sup>).

If the ignition load set has been changed:

- ▶ Re-check start behaviour.

### 7. Deactivate E-Parameters

Burner must be in Standby (OFF).

- ▶ Press [Enter] and [+] keys simultaneously for approx. 2 seconds.
- ✓ The parameter level is activated.
- ▶ Press [+].
- ▶ Press [Enter] key until parameter E is displayed.
- ▶ Set parameter E to OFF.
- ✓ E-Parameters are not shown in the setting level.
- ▶ Press [Enter] key twice.
- ✓ Combustion manager returns to the operating level.

## 6 Commissioning

### 6.3 Oil burner

#### 1. Preset combustion manager

- ▶ Unplug bridging plug No. 7 on combustion manager.
- ▶ Switch on voltage supply.
- ✓ The unprogrammed condition of the combustion manager is indicated by a flashing display.  
The burner goes to lockout.

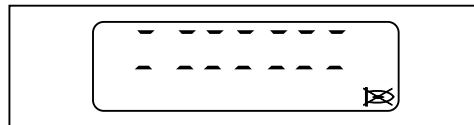

- ▶ Press [ENTER] key.
- ✓ Burner has been reset.
- ✓ Combustion manager drives to Standby.



If an oil pressure switch is fitted, set parameters 7 and 8 to 1 (see Ch. 4.2.3.3).  
If an air pressure switch is fitted, set parameter 8 to 1 (see Ch. 4.2.3.3).

- ▶ Press [G] and [L/A] simultaneously.
- ✓ Combustion manager changes to access level.



- ▶ Press [+].
- ✓ Setting level (parameter E0) is displayed.

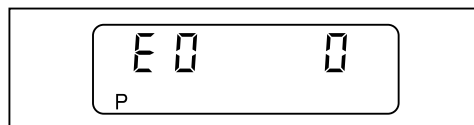

- ▶ Adopt value 0 (single fuel burner), if necessary adjust using [ENTER] and [-] key.
- ▶ Press [+].
- ✓ E1 is displayed.

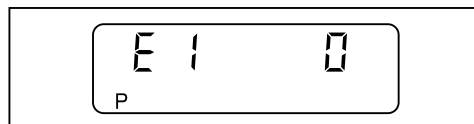

The value of parameter E1 can not be altered.

- 0 = intermittent operation (Standard)
- 1 = continuous operation (only if W-FM 21 was used previously)

## 6 Commissioning

- ▶ Press [+].
- ✓ E2 is displayed.

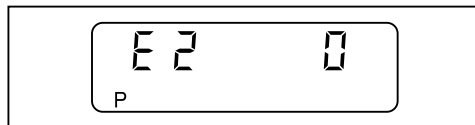

- ▶ Set value 2 (flame sensor QRB) using [ENTER] and [+] key.
- ▶ Press [+].
- ✓ E3 is displayed.

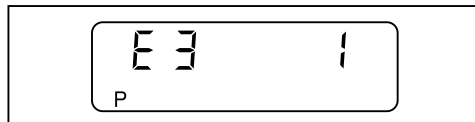

- ▶ Adopt value 1 (fan control), if necessary set using [ENTER] and [-] or [+] key.
- ▶ Press [+].
- ✓ E4 is displayed.

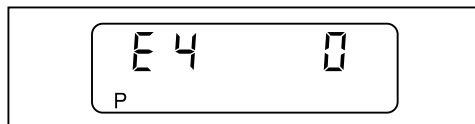

- ▶ Adopt value 0 (no ignition delay), if necessary set using [ENTER] and [-].
- ▶ Press [+].
- ✓ Combustion manager changes into the setting level for step points.

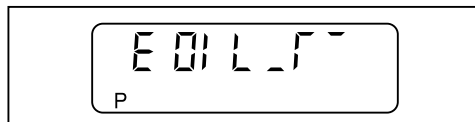

- ▶ Determine the air damper setting for operating points P9, P1 P0 and P2 from the sticker for burner setting.

The operating points are preset using these values:

- ▶ Press [+].
- ✓ Factory setting operating point P9 (Full load) is displayed.



- ▶ Press and hold [L/A] and set air damper setting using the [-] or [+] key.

## 6 Commissioning

- ▶ Press [+].
- ✓ Factory setting operating point P1 (stage 1) is displayed.

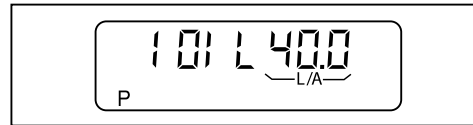

- ▶ Press and hold [L/A] and set air damper setting using the [-] or [+] key.
- ▶ Press [+].
- ✓ Factory setting operating point P9 (ignition position) is displayed.

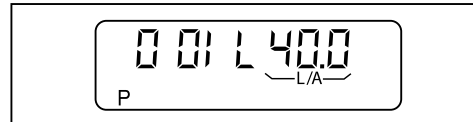

- ▶ Press and hold [L/A] and set air damper setting using the [-] or [+] key.
- ▶ Press [+].
- ✓ Factory setting operating point P2 (switch off point stage 2 when running closed) is displayed.

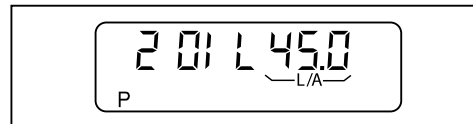

- ▶ Press and hold [L/A] and set air damper setting using the [-] or [+] key.
- ▶ Press [+].
- ✓ Factory setting operating point P3 (switch on point stage 2 when running open) is displayed.

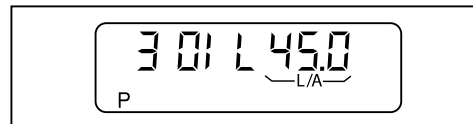

- ▶ Press and hold [L/A] and set the same values as for P2 using the [-] or [+] key.
- ▶ Press [+].
- ✓ Combustion manager is preset.



## 6 Commissioning

### 2. Adjusting the operating points

- ▶ Open oil shut off devices.



If a controlled shutdown or lockout occurs during setting:

- ▶ Press [G] and [L/A] simultaneously.
- ✓ Combustion manager changes into the setting level of operating points.

- ▶ Plug in bridging plug No. 7 on combustion manager.
- ✓ Burner starts in accordance with program sequence and stops in operating point P<sup>0</sup> (ignition position).



- ▶ Check combustion and if necessary adjust combustion values via air damper setting.
- ▶ Press [+].
- ✓ Burner drives to P<sup>1</sup>.

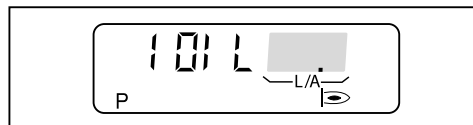

- ▶ Check combustion and if necessary adjust combustion values via air damper setting.
- ▶ Press [+].
- ✓ Burner drives to P<sup>9</sup>.

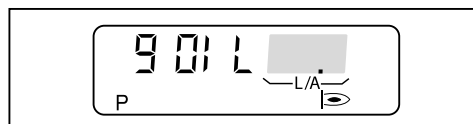

- ▶ Check combustion and if necessary adjust combustion values via air damper setting.
- ▶ Press [+].
- ✓ Switch off point stage 2 when running closed (P<sup>2</sup>) is displayed.



Set switch off point stage 2 when running closed (P<sup>2</sup>) to approx. 1/3 of the setting movement between P<sup>1</sup> and P<sup>9</sup>.

$$P2 = (P9 - P1) \cdot 0,33 + P1$$

- ▶ Press and hold [L/A] key and set P<sup>2</sup> using [-] or [+] key.

## 6 Commissioning

- ▶ Press [+].
- ✓ Switch on point stage 2 when running open (P<sup>3</sup>) is displayed.



- ▶ Press and hold [L/A] and set the same values as for P<sup>2</sup> using the [-] or [+] key.
- ▶ Press [G] and [L/A] simultaneously.
- ✓ Combustion manager changes to operating level (1<sup>0</sup>), depending on heat demand stage 1 or stage 2 is displayed.



### 3. Check start behaviour and on/off switch points

- ▶ Switch off and restart burner.
- ▶ Check start behaviour.
- ▶ Check on and off switch point stage 2:
  - excess air phase prior to switch over must not be too long,
  - flame must not fail.
- ▶ If necessary correct ignition position P<sup>0</sup>.
- ▶ If necessary correct switch on and point P<sup>3</sup> or switch off point P<sup>2</sup>.

If the existing settings have been changed:

- ▶ Re-check start behaviour and on and off switch points.

### 4. Deactivate E-Parameters

Burner must be in Standby (OFF).

- ▶ Press [Enter] and [+] keys simultaneously for approx. 2 seconds.
- ✓ The parameter level is activated.
- ▶ Press [+].
- ▶ Press [Enter] key until parameter E is displayed.
- ▶ Set parameter E to OFF.
- ✓ E-Parameters are not shown in the setting level.
- ▶ Press [Enter] key twice.
- ✓ Combustion manager returns to the operating level.

## 6 Commissioning

### 6.4 Dual fuel burner

#### 6.4.1 Adjusting gas side

##### 1. Preset combustion manager

- ▶ Set fuel selection switch to GAS.
- ▶ Unplug bridging plug No. 7 on combustion manager.
- ▶ Switch on voltage supply.
- ✓ The unprogrammed condition of the combustion manager is indicated by a flashing display.  
The burner goes to lockout.

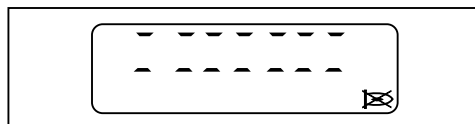

- ▶ Press [ENTER] key.
- ✓ Burner has been reset.
- ✓ Combustion manager drives to Standby.

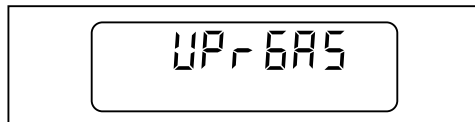

- ▶ Press [G] and [L/A] simultaneously.
- ✓ Combustion manager changes to access level.

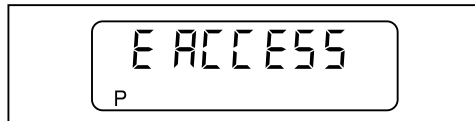

- ▶ Press [+].
- ✓ Setting level (parameter E0) is displayed.

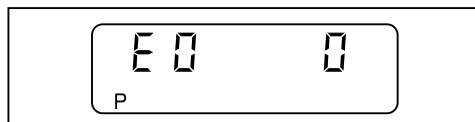

- ▶ Set value 1 (dual fuel burners) using [ENTER] and [+] key.
- ▶ Press [+].
- ✓ E1 is displayed.

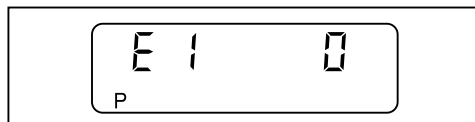

- ▶ Adopt value 0 (intermittent operation) using [+] key.
- ✓ E2 is displayed.

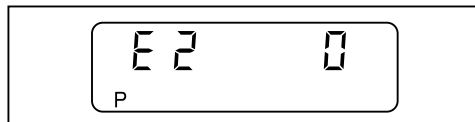

## 6 Commissioning

- ▶ Adopt value 0 (flame sensor FLW), if necessary set using [ENTER] and [-] key.
- ▶ Press [+].
- ✓ E3 is displayed.

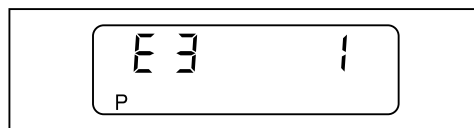

- ▶ Adopt value 1 (fan control), if necessary set using [ENTER] and [-] or [+] key.
- ▶ Press [+].
- ✓ Combustion manager changes into the setting level for step points.

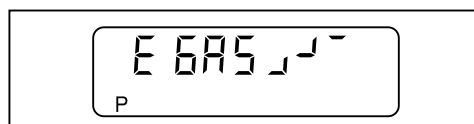

- ▶ Determine the air damper and gas butterfly valve setting for operating points P0, P1 and P9 from the sticker for burner setting.

The operating points are preset using these values:

- ▶ Press [+].
- ✓ Factory setting operating point P9 (Full load) is displayed.



- ▶ Press and hold [L/A] and set air damper setting using the [-] or [+] key.
- ▶ Press and hold [G] and set gas butterfly valve setting using the [-] or [+] key.
- ▶ Press [+].
- ✓ Factory setting operating point P1 (partial load) is displayed.



- ▶ Press and hold [L/A] and set air damper setting using the [-] or [+] key.
- ▶ Press and hold [G] and set gas butterfly valve setting using the [-] or [+] key.



## 6 Commissioning

- ▶ Press [+].
- ✓ Factory setting operating point P0 (ignition load) is displayed.



- ▶ Press and hold [L/A] and set air damper setting using the [-] or [+] key.
- ▶ Press and hold [G] and set gas butterfly valve setting using the [-] or [+] key.
- ▶ Press [+].
- ✓ Combustion manager is preset.

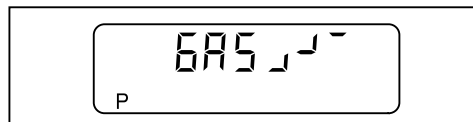

### 2. Check sequence of operation

- ▶ Open gas isolating valve.
- ✓ Gas pressure in gas valve train increases.
- ▶ Close isolating valve.
- ▶ Plug in bridging plug No. 7 on combustion manager.
- ✓ Burner starts.
- ▶ Check sequence of operation:
  - Valves open.
  - Gas pressure switch reacts.
  - Burner start is interrupted.
  - Low gas program starts.

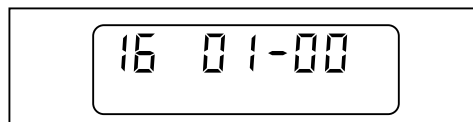

- ▶ Unplug 7 pole connection plug and plug it in again.
- ✓ Low gas program is interrupted.

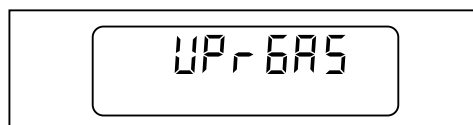

### 3. Adjusting the operating points



If a controlled shutdown or lockout occurs during setting:

- ▶ Press [-] and [+] simultaneously.
- ▶ Then press [+] key.
- ✓ Combustion manager changes to setting level.

- ▶ Open gas isolating valve.
- ▶ Press [-] and [+] simultaneously.
- ✓ The display shows E ACCESS.



## 6 Commissioning

- ▶ Press [+].
- ✓ Burner starts according to the sequence of operation and stops at operating point P<sup>0</sup> (ignition load).

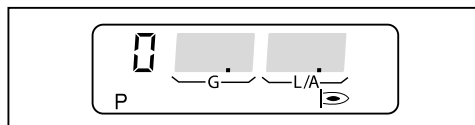

- ▶ Check combustion and if necessary adjust via air damper or gas butterfly setting.
- ▶ Press [+].
- ✓ Burner drives to P1.

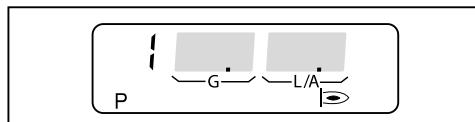

- ▶ Check combustion and if necessary adjust via air damper or gas butterfly setting.
- ▶ Press [+].
- ✓ Burner drives to P2.
- ▶ Determine the air damper and gas butterfly valve setting for operating point P2.
- ▶ Preset P2 with these values.
- ▶ Check combustion and if necessary adjust via air damper or gas butterfly setting.
- ▶ Repeat steps for each operating point until P<sup>9</sup> has been reached.



### 4. Adjust full load

- ▶ Press [G] and [L/A] simultaneously.
- ✓ Burner drives to full load.
- ✓ The upper operating limit (bo) is displayed.

If necessary, full load can be adjusted using [-] or [+] keys.

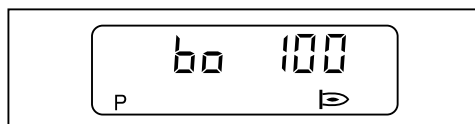

## 6 Commissioning

### 5. Adjust partial load

- ▶ Press [G] and [L/A] simultaneously.
- ✓ Burner drives to partial load.
- ✓ The lower operating limit is displayed (bu).

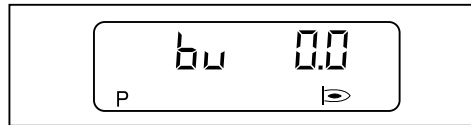

The value bu is given in percent on the W-FM 25, on the W-FM 20 ... 24 bu corresponds with the air damper setting.

- ▶ Determine gas throughput for partial load from test sheet.
- ▶ Set bu using [-] or [+] key.
- ▶ Determine gas throughput and adjust value.
- ▶ Press [G] and [L/A] simultaneously.
- ✓ Combustion manager changes to operating level (10).
- ✓ Combustion manager is programmed.



### 6. Check start behaviour

- ▶ Switch off and restart burner.
- ▶ Check start behaviour and if necessary correct ignition load (P0).

If the ignition load set has been changed:

- ▶ Re-check start behaviour.

## 6 Commissioning

### 6.4.2 Adjusting oil side

#### 1. Preset combustion manager

- ▶ Set fuel selection switch to OIL.
- ▶ Unplug bridging plug No. 7 on combustion manager.
- ▶ Switch on voltage supply.
- ✓ The unprogrammed condition of the combustion manager is indicated by a flashing display.  
The burner goes to lockout.

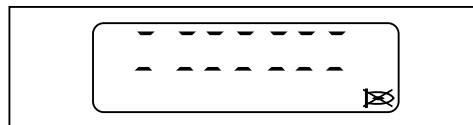

- ▶ Press [ENTER] key.
- ✓ Burner has been reset.
- ✓ Combustion manager drives to Standby.

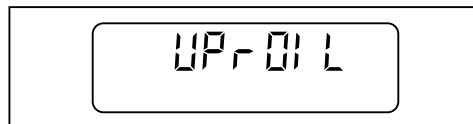

Parameters 7 and 8 must be set to value 1.

- ▶ Press [Enter] and [+] keys simultaneously for approx. 2 seconds.
- ✓ The parameter level is activated.
- ▶ Press [+].
- ▶ Press [Enter] key until parameter 7 is displayed.
- ▶ Set parameter 7 (oil pressure switch) to value 1 (activated).
- ▶ Press [Enter] key.
- ▶ Set parameter 8 (air pressure switch) to value 1 (activated).
- ▶ Press [Enter] key until parameter OFFUPr is displayed again.
- ▶ Press [G] and [L/A] simultaneously.
- ✓ Combustion manager changes to access level.



- ▶ Press [+].
- ✓ Setting level (parameter E0) is displayed.

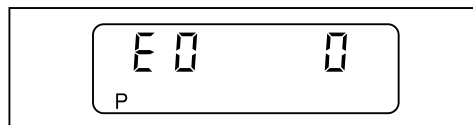

- ▶ Set value 1 (dual fuel burners) using [ENTER] and [+] key.
- ▶ Press [+].
- ✓ E1 is displayed.

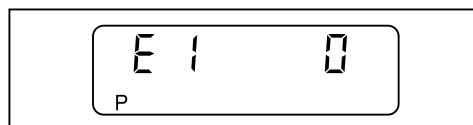

## 6 Commissioning

- ▶ Adopt value 0 (intermittent operation) using [+] key.
- ✓ E2 is displayed.

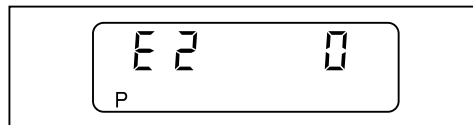

- ▶ Adopt value 0 (flame sensor FLW), if necessary set using [ENTER] and [-] key.
- ▶ Press [+].
- ✓ E3 is displayed.

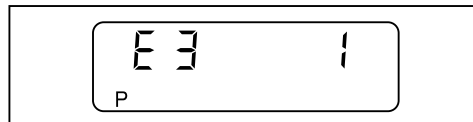

- ▶ Adopt value 1 (fan control), if necessary set using [ENTER] and [-] or [+] key.
- ▶ Press [+].
- ✓ Combustion manager changes into the setting level for step points.

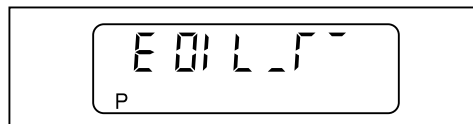

- ▶ Determine the air damper setting for operating points P9, P1 P0 and P2 from the sticker for burner setting.

The operating points are preset using these values:

- ▶ Press [+].
- ✓ Factory setting operating point P9 (Full load) is displayed.



- ▶ Press and hold [L/A] and set air damper setting using the [-] or [+] key.
- ▶ Press [+].
- ✓ Factory setting operating point P1 (stage 1) is displayed.

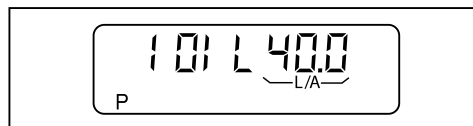

- ▶ Press and hold [L/A] and set air damper setting using the [-] or [+] key.
- ▶ Press [+].
- ✓ Factory setting operating point P9 (ignition position) is displayed.

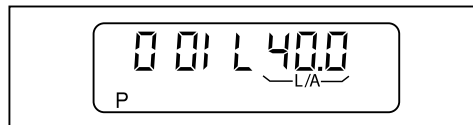

- ▶ Press and hold [L/A] and set air damper setting using the [-] or [+] key.

## 6 Commissioning

- ▶ Press [+].
- ✓ Factory setting operating point P2 (switch off point stage 2 when running closed) is displayed.

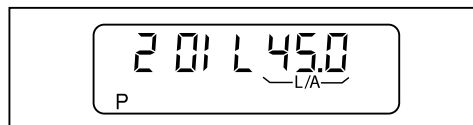

- ▶ Press and hold [L/A] and set air damper setting using the [-] or [+] key.
- ▶ Press [+].
- ✓ Factory setting operating point P3 (switch on point stage 2 when running open) is displayed.



- ▶ Press and hold [L/A] and set the same values as for P2 using the [-] or [+] key.
- ▶ Press [+].
- ✓ Combustion manager is preset.

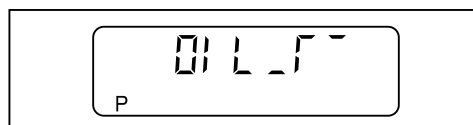

### 2. Adjusting the operating points

- ▶ Open oil shut off devices.



If a controlled shutdown or lockout occurs during setting:

- ▶ Press [G] and [L/A] simultaneously.
- ✓ Combustion manager changes into the setting level of operating points.

- ▶ Plug in bridging plug No. 7 on combustion manager.
- ✓ Burner starts in accordance with program sequence and stops in operating point P0 (ignition position).



- ▶ Check combustion and if necessary adjust combustion values via air damper setting.
- ▶ Press [+].
- ✓ Burner drives to P1.



- ▶ Check combustion and if necessary adjust combustion values via air damper setting.

## 6 Commissioning

- ▶ Press [+].
- ✓ Burner drives to P<sup>9</sup>.



- ▶ Check combustion and if necessary adjust combustion values via air damper setting.
- ▶ Press [+].
- ✓ Switch off point stage 2 when running closed (P<sup>2</sup>) is displayed.



Set switch off point stage 2 when running closed (P<sup>2</sup>) to approx. 1/3 of the setting movement between P<sup>1</sup> and P<sup>9</sup>.

$$P2 = (P9 - P1) \cdot 0,33 + P1$$

- ▶ Press and hold [L/A] key and set P<sup>2</sup> using [-] or [+] key.
- ▶ Press [+].
- ✓ Switch on point stage 2 when running open (P<sup>3</sup>) is displayed.



- ▶ Press and hold [L/A] and set the same values as for P<sup>2</sup> using the [-] or [+] key.
- ▶ Press [G] and [L/A] simultaneously.
- ✓ Combustion manager changes to operating level (1<sup>0</sup>), depending on heat demand stage 1 or stage 2 is displayed.



### 3. Check start behaviour and on/off switch points

- ▶ Switch off and restart burner.
- ▶ Check start behaviour.
- ▶ Check on and off switch point stage 2:
  - excess air phase prior to switch over must not be too long,
  - flame must not fail.
- ▶ If necessary correct ignition position P<sup>0</sup>.
- ▶ If necessary correct switch on and point P<sup>3</sup> or switch off point P<sup>2</sup>.

If the existing settings have been changed:

- ▶ Re-check start behaviour and on and off switch points.

## 6 Commissioning

### 4. Deactivate E-Parameters

Burner must be in Standby (OFF).

- ▶ Press [Enter] and [+] keys simultaneously for approx. 2 seconds.
- ✓ The parameter level is activated.
- ▶ Press [+].
- ▶ Press [Enter] key until parameter E is displayed.
- ▶ Set parameter E to OFF.
- ✓ E-Parameters are not shown in the setting level.
- ▶ Press [Enter] key twice.
- ✓ Combustion manager returns to the operating level.



## 7 Troubleshooting

### 7 Troubleshooting

#### 7.1 Procedures for fault conditions



##### Damage resulting from incorrect servicing

The combustion plant could be damaged.

- ▶ Do not carry out more than 2 lockout resets successively.
- ▶ Faults must be rectified by qualified personnel.

##### 7.1.1 Display off

If the burner does not start despite heat demand:

- ▶ Check voltage supply
- ▶ Check unit fuse F7 (see Ch. 3.1).
- ▶ On burner size W30 and W40, the contactor can be fitted to a separate voltage supply from the burner motor if required (contactor available as accessory).
- ▶ Check function and setting of all regulating, control and safety devices.
- ▶ Check all burner related functions.

##### 7.1.2 Display flashes

A burner fault has occurred. The burner is in lockout. The error code is displayed flashing.

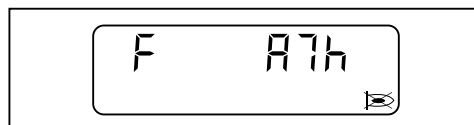

##### Fault codes

- ▶ Read error code, e. g. A7h.
- ▶ If required, additional information can be displayed by pressing the key (see Ch. 7.1.3).
- ▶ Rectify cause of fault (see Ch. 7.2).

##### Resetting

- ▶ Press [ENTER] key.
- ✓ Burner has been reset.

##### Fault memory

The last 9 faults are saved in the fault memory (see Ch. 4.2.2).

## 7 Troubleshooting

### 7.1.3 Detailed fault code

This code contains additional information about the fault that has occurred.  
Additional information about the fault can be displayed by pressing the key:

1. Detailed fault code / operating phase

▶ Press [+] key.

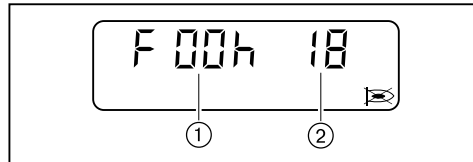

- ① 1. Detailed fault code
- ② Operating phase (see Ch. 9.1)

2. Detailed fault code

▶ Press keys [+] and [-] simultaneously.



3. Detailed fault code

▶ Press key [L/A].

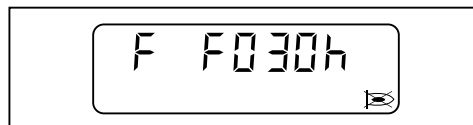

Repetition counter

▶ Press key [G].

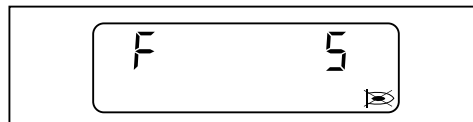

**7 Troubleshooting**

**7.2 Rectifying faults**

<b>Fault code</b>	<b>Cause</b>	<b>Rectification</b>
01h ... 02h 05h ... 0bh 0dh ... 10h 13h ... 15h 17h 19h ... 1Ch 1Eh 43h 45h 50h 56h 69h ... A0h A4h ... A5h ACh b0h ... b2h b9h d4h	Internal unit fault	<ul style="list-style-type: none"> <li>▶ Interrupt the voltage supply temporarily</li> <li>▶ Reset the burner, if fault reoccurs replace the combustion manager</li> </ul>

<b>Fault code</b>	<b>Cause</b>	<b>Rectification</b>
03h	Ambient temperature too high	<ul style="list-style-type: none"> <li>▶ Interrupt the voltage supply temporarily</li> <li>▶ Check ambient temperature</li> <li>▶ Reset the burner, if fault reoccurs replace the combustion manager</li> </ul>
	Excess voltage	<ul style="list-style-type: none"> <li>▶ Interrupt the voltage supply temporarily</li> <li>▶ Check voltage supply</li> <li>▶ Reset the burner, if fault reoccurs replace the combustion manager</li> </ul>
04h	More than 5 resets in the last 15 minutes	<ul style="list-style-type: none"> <li>▶ Wait 3 minutes</li> <li>▶ Rectify cause of fault</li> </ul>
0Ch	Burner configuration incorrect	<ul style="list-style-type: none"> <li>▶ Check burner configuration</li> <li>▶ Check parameter E0 ... E4 (see Ch. 4.2.4)</li> </ul>
11h	Low voltage	<ul style="list-style-type: none"> <li>▶ Check voltage supply</li> </ul>
12h	Voltage supply was temporarily interrupted	<ul style="list-style-type: none"> <li>▶ Check voltage supply</li> </ul>
16h	Communication with TWI interface (Vision Box) incorrect	<ul style="list-style-type: none"> <li>▶ Plug in and unplug participants on the TWI Bus only when de-energised</li> <li>▶ Reduce the number of participants on the TWI Bus</li> <li>▶ Reduce cable length</li> </ul>

**7 Troubleshooting**

<b>Fault code</b>	<b>Cause</b>	<b>Rectification</b>
18h	Switch off via PC Software	–
	2. Detailed fault code: A1h Invalid Fieldbus address	▶ Check Fieldbus address
	2. Detailed fault code: A5h Configuration at output B4 incorrect	▶ Check configuration at output B4
	2. Detailed fault code: A6h No keystrokes where made for 30 minutes in the setting mode	–
	2. Detailed fault code: A7h Off function was activated	–
	2. Detailed fault code: A8h No calibration values were stored in the EEPROM	–
	2. Detailed fault code: A9h No bus connection	▶ Check bus connection
1dh	EMC interference	▶ Improve EMC measures
40h	Speed standardisation outside of limit set	▶ Carry out speed standardisation
41h	1. Detailed fault code: 01h Speed differs for too long	▶ Check parameters 44 and 45
	1. Detailed fault code: 02h Speed difference is too great	▶ Check speed signal
	1. Detailed fault code: 03h Speed setting value outside of tolerance for too long	▶ Re-adjust burner ▶ Check parameters 44 and 45
42h	Speed signal (Namur) not plugged in	▶ Plug in speed signal
44h	Operating points were changed without approval	▶ Re-adjust burner
	Parameter E3 was changed	▶ Check parameter E3 (see Ch. 4.2.4)
	Parameter 46 was changed and speed was not re-standardised	▶ Re-adjust burner
46h	Rotational direction of burner incorrect	▶ Check rotation direction of burner motor
47h	Type of air actuator invalid	▶ Check parameter 34
	Type of gas actuator invalid	▶ Check parameter 35
48h	Plugs of actuators for gas and air mixed up	▶ Change over plugs
	Tolerance fault actuator	▶ Check freedom of movement of air damper, angle drive and gas butterfly valve ▶ Replace actuator
49h	Actuator does not drive to reference point correctly	▶ Check freedom of movement of air damper, angle drive and gas butterfly valve ▶ Replace actuator
4Ah	Set parameter E0 to 1 and plug in coded plug	▶ Check parameter E0 (see Ch. 4.2.4)

**7 Troubleshooting**

<b>Fault code</b>	<b>Cause</b>	<b>Rectification</b>
53h	Insufficient gas low gas pressure switch/ valve proving gas pressure switch	<ul style="list-style-type: none"> <li>▶ Check gas connection pressure</li> <li>▶ Set gas pressure switch</li> <li>▶ Check gas pressure switch</li> </ul>
63h	Speed learning curve incorrect	<ul style="list-style-type: none"> <li>▶ Re-adjust burner</li> </ul>
65h	1. Detailed fault code: 00h Tolerance fault air actuator, gas actuator or frequency converter	<ul style="list-style-type: none"> <li>▶ Check freedom of movement of air damper and/or angle drive</li> <li>▶ Check freedom of movement of gas butterfly valve</li> <li>▶ Replace actuator</li> <li>▶ Check frequency converter and fan, replace if necessary</li> </ul>
	1. Detailed fault code: 01h Tolerance fault air actuator or gas actuator	<ul style="list-style-type: none"> <li>▶ Check freedom of movement of air damper and/or angle drive</li> <li>▶ Check freedom of movement of gas butterfly valve</li> <li>▶ Replace actuator</li> </ul>
	1. Detailed fault code: 02h Tolerance fault gas actuator or frequency converter	<ul style="list-style-type: none"> <li>▶ Check freedom of movement of gas butterfly valve</li> <li>▶ Replace actuator</li> <li>▶ Check frequency converter and fan, replace if necessary</li> </ul>
	1. Detailed fault code: 03h Tolerance fault gas actuator	<ul style="list-style-type: none"> <li>▶ Check freedom of movement of gas butterfly valve</li> <li>▶ Replace actuator</li> </ul>
	1. Detailed fault code: 04h Tolerance fault air actuator or frequency converter	<ul style="list-style-type: none"> <li>▶ Check freedom of movement of air damper and/or angle drive</li> <li>▶ Replace actuator</li> <li>▶ Check frequency converter and fan, replace if necessary</li> </ul>
	1. Detailed fault code: 05h Tolerance fault air actuator	<ul style="list-style-type: none"> <li>▶ Check freedom of movement of air damper and/or angle drive</li> <li>▶ Replace actuator</li> </ul>
	1. Detailed fault code: 06h Tolerance fault frequency converter	<ul style="list-style-type: none"> <li>▶ Check frequency converter and fan, replace if necessary</li> </ul>
	1. Detailed fault code: 07h Time run out during speed standardisation	<ul style="list-style-type: none"> <li>▶ Press [+] key within 20 seconds during speed standardisation</li> </ul>
	1. Detailed fault code: 07h Time in setting mode run out	<ul style="list-style-type: none"> <li>▶ Press key within 30 minutes in setting mode</li> </ul>
67h	Flame sensor short circuit	<ul style="list-style-type: none"> <li>▶ Replace flame sensor</li> </ul>
68h	Flame frequency incorrect	<ul style="list-style-type: none"> <li>▶ Check flame sensor</li> <li>▶ Check burner setting</li> </ul>
A2h	Safety circuit open	<ul style="list-style-type: none"> <li>▶ Check safety circuit</li> </ul>
A6h	Flame simulation/Extraneous light	<ul style="list-style-type: none"> <li>▶ Find and eliminate extraneous light source</li> <li>▶ Check flame sensor or ionisation electrode</li> </ul>

**7 Troubleshooting**

<b>Fault code</b>	<b>Cause</b>	<b>Rectification</b>
A7h	No flame signal after safety time	<ul style="list-style-type: none"> <li>▶ Check oil nozzles, replace if necessary</li> <li>▶ Set ignition electrode(s)</li> <li>▶ Check the ignition unit and replace if necessary</li> <li>▶ Check solenoid valve and cable, replace if necessary</li> <li>▶ Check flame sensor or ionisation electrode and cable, replace if necessary</li> <li>▶ Check mixing pressure, if necessary reduce</li> <li>▶ Check burner setting</li> <li>▶ Replace combustion manager</li> </ul>
A8h	Flame failure during operation	<ul style="list-style-type: none"> <li>▶ Check burner setting</li> <li>▶ Check oil supply</li> <li>▶ Check oil nozzles, replace if necessary</li> <li>▶ Check flame sensor or ionisation electrode, replace if necessary</li> </ul>
A9h	Flame failure during stabilisation time (with pilot ignition)	▶ see A7h
AAh	Switch contact of air pressure switch not in Standby	<ul style="list-style-type: none"> <li>▶ Check air pressure switch and cable and replace if necessary</li> <li>▶ Replace combustion manager</li> </ul>
Abh	Air pressure switch does not react	<ul style="list-style-type: none"> <li>▶ Check hoses on air pressure switch</li> <li>▶ Check air pressure switch and cable and replace if necessary</li> <li>▶ Check burner motor and cable, if necessary replace</li> </ul>
Adh	Insufficient gas low gas pressure switch	<ul style="list-style-type: none"> <li>▶ Check gas connection pressure</li> <li>▶ Set gas pressure switch</li> <li>▶ Check gas pressure switch</li> </ul>
AEh	Valve 1 leaking during valve proving	<ul style="list-style-type: none"> <li>▶ Check soundness of gas valve train</li> <li>▶ Check setting and function of gas pressure switch</li> <li>▶ Replace double gas valve</li> <li>▶ Check parameter E0 (see Ch. 4.2.4)</li> </ul>
AFh	Valve 2 leaking during valve proving	<ul style="list-style-type: none"> <li>▶ Check soundness of gas valve train</li> <li>▶ Check setting and function of gas pressure switch</li> <li>▶ Replace double gas valve</li> </ul>
b6h	Fault POC contact	<ul style="list-style-type: none"> <li>▶ Check POC contact</li> <li>▶ Check double gas valve (valve 1)</li> </ul>
bAh	Flame simulation/extraneous light at start-up	<ul style="list-style-type: none"> <li>▶ Find and eliminate extraneous light source</li> <li>▶ Check flame sensor or ionisation electrode</li> </ul>
bbh	Burner shutdown via contact X3:7 (plug No. 7)	–
CAh	Valve proving faulty	<ul style="list-style-type: none"> <li>▶ Check low gas pressure switch/valve proving gas pressure switch</li> <li>▶ Check double gas valve</li> </ul>
CCh	Oil pressure switch does not switch	<ul style="list-style-type: none"> <li>▶ Check oil supply</li> <li>▶ Check oil pump, if necessary replace</li> <li>▶ Check oil pressure switch and cable, if necessary replace</li> <li>▶ Check pump motor and cable, if necessary replace</li> </ul>
Cdh	LDW 2 does not switch	<ul style="list-style-type: none"> <li>▶ Check hoses on air pressure switch</li> <li>▶ Check air pressure switch and cable and replace if necessary</li> </ul>

**7 Troubleshooting**

<b>Fault code</b>	<b>Cause</b>	<b>Rectification</b>
CEh	Bridging plug No. 15 is missing	▶ Plug in bridging plug
	High gas pressure switch does not switch	▶ Check gas connection pressure ▶ Set gas pressure switch ▶ Check gas pressure switch
CFh	No start release (X3:14)	▶ Check start release
d0h	Fuel change-over during ignition phase	▶ Check fuel change-over
d1h	Connection to actuator faulty	▶ Check the connection
	Coded plug on actuator slot missing	▶ Plug in coded plug
d2h	More than 5 resets in the last 15 minutes by remote reset (X3:14)	▶ Rectify cause of fault ▶ Carry out reset using operating panel (AM)

8 Spares

8 Spares

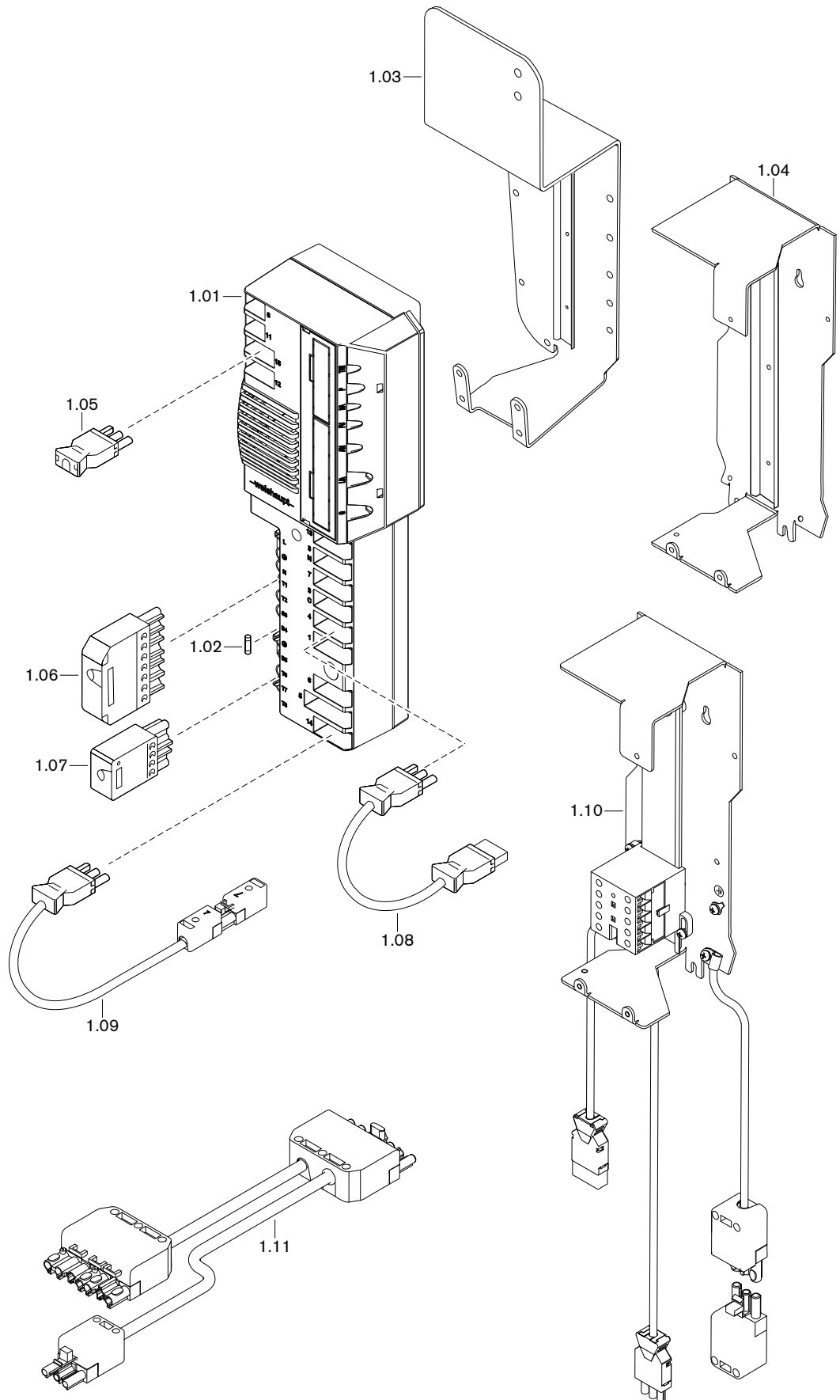



**8 Spares**

<b>Pos.</b>	<b>Description</b>	<b>Order No.</b>
1.01	Combustion manager W-FM 25	
	– intermittent operation	600 478
	– continuous operation	600 479
1.02	Micro fuse 6.3 AT	722 024
1.03	Bracket with carrier rail WG10/20	232 110 12 09 2
1.04	Bracket with carrier rail WG30/40	232 310 12 02 2
1.05	Bridging plug No. 15	232 110 12 08 2
1.06	Plug unit ST18/7	716 549
1.07	Plug unit ST18/4	716 546
1.08	Extension cable No. 4 ignition device	230 310 12 53 2
1.09	Plug cable No. 14 for remote reset	230 110 12 36 2
1.10	Contacteur 230 V with bracket	230 310 12 51 2
	– Contacteur B6-30-01 220-240 V	701 916
1.11	Plug cable sep. motor voltage supply	230 110 12 48 2

**9 Technical documentation**

**9 Technical documentation**

**9.1 Program sequence**

Display	Operating phase	Condition
F ..	00	Fault present
OFFUPr UPrGAS UPrOIL	01	Waiting in unprogrammed condition
OFF OFFGAS OFFOIL	02	Waiting for heat demand
1	03	Extraneous light check
2	04	Shutdown check air pressure switch
	05	Initialisation W-FM
	06	Waiting for start release
	07	Internal sequence
	08	Driving air damper actuator to pre-purge
3	09	Waiting for speed standardisation confirmation
	10	Start burner motor
	11	Waiting for air pressure
4	12	Pre-purge
	13	Internal sequence
5	14	Driving to ignition position
6	15	Gas pressure check on low / valve proving gas pressure switch
	16	Pre-ignition
7	17	First safety time - fuel release
	18	First safety time - flame detection
8	19	First stabilisation time
	20	Stop setting mode: P0 -A
	21	Second safety time
	22	Second stabilisation time
	23	End setting mode: P0 -B
9	24	Driving to partial load
10	25	Operation (load control is activated)
15	26	Internal sequence
	27	Driving to partial load
	28	Fuel valves close
	29	Internal sequence
	30	Start post burn time / post-purge
	31	Post-purge contact dependent (X3:14)
	32	Post burn time
16	33	Restart interlock
11	34	Valve proving - vent valve interspace
12	35	Valve proving - test time valve 1
	36	Internal sequence
13	37	Valve proving - fill valve interspace

**9 Technical documentation**

Display	Operating phase	Condition
14	38	Valve proving - test time valve 2
	39	Internal sequence
L/G	40	Reference search actuator air damper and gas butterfly valve
G	41	Test gas butterfly valve actuator 105°
L/G	42	Drive to Standby position
	43	Internal sequence
OFFGd	44	Insufficient gas low gas pressure switch (X3:14)
16 . . . .	45	Low gas programme
OFF S	46	Safety circuit open (X3:7)

**10 Notes**

**10 Notes**

**10 Notes**

11 Key word index

<b>A</b>		Program sequence .....66
Access level .....28		
Ambient conditions ..... 13		
<b>C</b>		<b>R</b>
Calculation .....29		Reset .....57
Consumption ..... 13		Reset key ..... 14
Contactor ..... 31, 57		<b>S</b>
<b>D</b>		Safety measures ..... 7
Detailed fault code .....58		Service level ..... 20, 21, 22
Digital load converter ..... 9, 10, 11, 12		Smell of gas ..... 7
Dimensions ..... 13		Spares .....65
Display ..... 14, 16		Storage ..... 13
Display and operating unit ..... 14		<b>T</b>
Disposal ..... 8		Temperature ..... 13
DLU ..... 9, 10, 11, 12		Transport ..... 13
<b>F</b>		Type of protection ..... 13
Fault .....57		<b>V</b>
Fault code .....59		Voltage supply ..... 13
Fault memory ..... 20, 21, 22, 57		
Fusing .....9, 10, 11, 12, 13, 57, 65		
<b>G</b>		
Guarantee ..... 6		
<b>H</b>		
Humidity ..... 13		
<b>I</b>		
Info key ..... 14		
Info level ..... 17, 18, 19		
Input ..... 9, 10, 11, 12		
Interface ..... 9, 10, 11, 12		
<b>L</b>		
Liability ..... 6		
Linearisation .....29		
Lockout .....57		
<b>M</b>		
Mains voltage ..... 13		
Motor contactor ..... 31, 57		
<b>O</b>		
Off function ..... 14		
Operating display .....66		
Operating level ..... 14		
Operating panel ..... 14		
Operating phase ..... 15, 58, 66		
Output ..... 9, 10, 11, 12		
<b>P</b>		
Parameter level ..... 23, 24, 25, 26		



## The complete program: Reliable technology and prompt, professional service

	<p><b>W Burners</b> <span style="float: right;"><b>up to 570 kW</b></span></p> <p>The compact burners, proven millions of times over, are economical and reliable. Available as gas, oil and dual fuel burners for domestic and commercial applications.</p> <p>The purflam® burner version with special mixing head gives almost soot-free combustion of oil with greatly reduced NOx emissions.</p>	<p><b>Wall-hung condensing boilers for oil and gas</b> <span style="float: right;"><b>up to 240 kW</b></span></p> <p>The wall-hung condensing boilers WTC-GW and WTC-OW have been developed to meet the highest demands in ease of operation and efficiency.</p> <p>Modulating operation means these units operate quietly and economically.</p>	
	<p><b>monarch® WM Burners and Industrial Burners</b> <span style="float: right;"><b>up to 11,700 kW</b></span></p> <p>These legendary industrial burners are durable and versatile.</p> <p>Numerous variations of oil, gas and dual fuel burners meet a wide range of applications and capacity requirements.</p>	<p><b>Floor standing condensing boiler for oil and gas</b> <span style="float: right;"><b>up to 1,200 kW</b></span></p> <p>The floor-standing boilers WTC-GB and WTC-OB are efficient, low in emissions and versatile. Higher capacities are achieved by cascading up to four gas-fired condensing boilers.</p>	
	<p><b>WK Burners</b> <span style="float: right;"><b>up to 28,000 kW</b></span></p> <p>These industrial burners of modular construction are adaptable, robust and powerful.</p> <p>Even on the toughest industrial applications these oil, gas and dual fuel burners operate reliably.</p>	<p><b>Solar systems</b></p> <p>The stylish flat-plate collectors are the ideal complement for any Weishaupt heating system. They are suitable for solar water heating and for combined heating support.</p> <p>With versions for on-roof, in-roof and flat roof installations, solar energy can be utilised on almost any roof.</p>	
	<p><b>multiflam® Burners</b> <span style="float: right;"><b>up to 17,000 kW</b></span></p> <p>This innovative Weishaupt technology for medium and large burners provides minimum emission values at capacities up to 17 MW.</p> <p>The burners with the patented mixing head are available for oil, gas and dual fuel operation.</p>	<p><b>Water heaters / energy storage tanks</b></p> <p>This attractive program for domestic water heating includes classic water heaters, solar storage tanks, heat pump storage tanks and energy storage tanks.</p>	
	<p><b>MCR Technology / Building Automation from Neuberger</b></p> <p>From control panels to complete building management systems - at Weishaupt you can find the entire spectrum of modern control technology. Future orientated, economical and flexible.</p>	<p><b>Heat pumps</b> <span style="float: right;"><b>up to 130 kW</b></span></p> <p>The heat pump range offers solutions for the utilisation of heat from the air, the soil or ground water.</p> <p>Some systems are also suitable for cooling buildings.</p>	
	<p><b>Service</b></p> <p>Weishaupt customers can be assured that specialist knowledge and tools are available whenever they are needed. Our service engineers are fully qualified and have extensive product knowledge, be it for burners, heat pumps, condensing boilers or solar collectors.</p>	<p><b>Geothermal probe drilling</b></p> <p>With its daughter company, BauGrund Süd, Weishaupt also offers geothermal probe and well drilling. With the experience of more than 10,000 systems and more than 2 million meters of drilling, BauGrund Süd offers a comprehensive service program.</p>	