

RZ and 210Z

Zero Governor Design

Both the RZ and 210Z series are adaptable for air-gas mixing applications. Because of the balanced valve construction, Z-models offer superior performance at an economical price compared with other types of atmospheric regulators.

Maxitrol's RZ and 210Z Zero Governor model regulators are used for flow control of burners, nozzle mixers, mixing tees and proportional premixers.



210EZ

Specifications

Pipe Sizes	RZ Models: 3/8" to 1" threaded connections with NPT or ISO7-1 threads. 210Z Models: 1" to 3" threaded connections with NPT or ISO7-1 threads. 4" 125 lb. flange (210JZ only).
Housing Material	R400Z, R500Z, R600Z, 210DZ, 210EZ, 210GZ, 210JZ: aluminum.
Mounting	R400Z, 210DZ, 210EZ, 210GZ, 210JZ mount in an upright position only. R500Z, R600Z suitable for multi-positional mounting. If ball check vent limiting device is installed, mount in an upright position only. NOTE: All Maxitrol gas pressure regulators should be installed and operated in accordance with Maxitrol Safety Warning Instructions (see GPR_MI_EN.ES or GPR_CSA_MI_EN.FR).
Certifications	R400Z, R500Z, 210DZ, 210EZ, 210GZ: ANSI Z21.18/CSA 6.3 Gas Appliance Pressure Regulators.
Gas Types	Suitable for natural, manufactured, mixed gases, liquefied petroleum gases, and LP gas-air mixtures.
Rated Inlet Pressure	CSA Certified: R400Z, R500Z: 1/2 psi (3.4 kPa); 210DZ, 210EZ, 210GZ: 5 psi (34.5 kPa)
Maxitrol Tested	R400Z, R500Z, R600Z: 1 psi (6.9 kPa); 210JZ: 5 psi (34.5 kPa)
Emergency Exposure Limits	R400Z, R500Z, R600Z: 2 psi (13.8 kPa) 210DZ, 210EZ, 210GZ, 210JZ: 25 psi (172 kPa)
Ambient Temperature Ranges	R400Z, R600Z: -40° to 205°F (-40° to 96°C) R500Z: 32° to 205°F (0° to 96°C) 210DZ, 210EZ, 210GZ, 210JZ: -40° to 200°F (-40° to 93°C)
Sensing Taps	210Z Models have convenient tap locations available for downstream sensing, cross connections, and differential control. Four locations can be tapped and plugged for measuring pressure.
Remote Sensing	210DZ, 210EZ, 210GZ models may be ordered with remote sensing. The internal sensing tube is omitted and external sensing taps are provided. Add suffix letter "R" to model number when ordering.
Minimum Regulation	R400Z: Suitable for pilot flow applications. (P) (Circle P) (0.15 CFH NG), R500Z, R600Z: 10 CFH.



Capacities and Pressure Drop

Capacities expressed in CFH (m³/h) @ 0.64 sp gr gas

Model Number	Pipe Size	Pressure Drop - inches w.c. (kPa)										
		0.2 (0.05)	0.4 (0.10)	0.6 (0.15)	0.8 (0.20)	1.0 (0.25)	1.5 (0.37)	2.0 (0.50)	2.5 (0.62)	3.0 (0.75)	3.5 (0.87)	4.0 (1.0)
R400Z	3/8" x 3/8"	77 (2.16)	110 (3.08)	134 (3.75)	155 (4.34)	174 (4.87)	212 (5.94)	245 (6.86)	274 (7.67)	--	--	--
	1/2" x 1/2"	86 (2.41)	121 (3.39)	148 (4.14)	172 (4.82)	192 (5.38)	235 (6.58)	271 (7.59)	303 (8.48)	--	--	--
R500Z	1/2" x 1/2"	163 (4.56)	231 (6.47)	283 (7.92)	327 (9.16)	366 (10.3)	447 (12.5)	516 (14.6)	577 (16.2)	635 (17.8)	685 (19.2)	730 (20.4)
	3/4" x 3/4"	196 (5.49)	277 (7.76)	340 (9.52)	392 (11.0)	438 (12.3)	537 (15.0)	620 (17.4)	693 (19.4)	760 (21.3)	820 (22.7)	876 (24.5)
R600Z	3/4" x 3/4"	298 (8.34)	421 (11.8)	516 (14.5)	595 (16.7)	666 (18.7)	816 (22.9)	942 (26.4)	1054 (29.5)	1150 (32.2)	1245 (34.9)	1335 (37.4)
	1" x 1"	330 (9.24)	468 (13.1)	572 (16.0)	661 (18.2)	739 (20.7)	906 (25.4)	1046 (29.3)	1169 (32.7)	1280 (35.8)	1380 (38.6)	1480 (41.4)

NOTE: CSA maximum capacities vary with spring range and pipe size. Please contact Maxitrol directly for CSA maximums. See pages 58-59 for Regulator Sizing Requirements and Examples.

RZ and 210Z

Zero Governor Design

Capacities and Pressure Drop

Capacities expressed in CFH (m³/h) @ 0.64 sp gr gas

Model Number	Pipe Size	Pressure Drop - inches w.c. (kPa) unless noted										
		0.1 (0.025)	0.3 (0.075)	0.5 (0.125)	1.0 (0.25)	3.0 (0.75)	5.0 (1.25)	7.0 (1.74)	0.5 psi (3.45)	0.75 psi (5.17)	1 psi (6.89)	1.5 psi (10.34)
210DZ	1" x 1"	--	--	--	900 (25.2)	1600 (44.8)	2000 (56.0)	2400 (67.2)	3300 (92.4)	4100 (115)	4750 (133)	5800 (162)
	1 1/4" x 1 1/4"	--	--	--	1100 (30.8)	1900 (53.2)	2500 (70.0)	2900 (81.2)	4100 (115)	5000 (140)	5850 (164)	7150 (200)
	1 1/2" x 1 1/2"	--	--	--	1200 (33.6)	2100 (58.8)	2700 (75.6)	3200 (89.6)	4500 (126)	5500 (154)	6350 (176)	7750 (217)
210EZ	1 1/2" x 1 1/2"	--	1050 (29.4)	1350 (37.8)	1915 (53.6)	3315 (92.8)	4280 (120)	5065 (142)	7125 (199)	8725 (244)	10075 (282)	12340 (345)
	2" x 2"	--	1210 (33.9)	1560 (43.7)	2210 (61.9)	3825 (107)	4940 (139)	5845 (164)	8225 (230)	10070 (282)	11630 (326)	14245 (399)
210GZ	2 1/2" x 2 1/2"	1410 (39.5)	2450 (68.6)	3160 (88.5)	4470 (125)	7740 (217)	9995 (280)	11825 (331)	16635 (466)	20370 (570)	23525 (659)	28810 (807)
	3" x 3"	1555 (43.5)	2695 (75.5)	3475 (97.3)	4920 (138)	8520 (239)	11000 (308)	13020 (365)	18310 (513)	22425 (628)	25890 (725)	31710 (888)
210JZ	4" x 4"	2700 (75.6)	4700 (132)	6000 (168)	8600 (241)	15000 (420)	19000 (532)	23000 (644)	32000 (896)	40000 (1120)	45500 (1274)	55700 (1560)

NOTE: CSA maximum capacities vary with spring range and pipe size. Please contact Maxitrol directly for CSA maximums.
See pages 58-59 for Regulator Sizing Requirements and Examples.

Spring Selection: inches w.c (kPa)

Model	Outlet Pressure Range
R400Z	-1.5 to 1.0 (-0.37 to 0.25)
R500Z	-1.0 to 2.5 (-0.25 to 0.62)
R600Z	-1.0 to 1.5 (-0.25 to 0.37)

Model	Outlet Pressure Range
210DZ	-1.0 to 1.5 (-0.25 to 0.37)
210EZ	-1.0 to 1.5 (-0.25 to 0.37)
210GZ	-1.0 to 1.5 (-0.25 to 0.37)
210JZ	-1.0 to 1.5 (-0.25 to 0.37)

NOTE: See pages 56-57 for complete Spring Selection Chart.

RZ and 210Z

Zero Governor Design

Dimensions

Model	Pipe Size	Vent Connection	Swing Radius	Dimensions			
				A	B	C	D
R400Z	3/8", 1/2"	1/8" NPT	2.4" (60 mm)	3.3" (83 mm)	2" (51 mm)	2" (51 mm)	0.9" (24 mm)
R500Z	1/2", 3/4"	1/8" NPT	3.6" (90 mm)	4.7" (119 mm)	3.1" (79 mm)	3" (79 mm)	1.2" (30 mm)
R600Z	3/4", 1"	1/8" NPT	4.3" (109 mm)	5.7" (144 mm)	3.9" (98 mm)	4" (102 mm)	1.5" (37 mm)
210DZ	1", 1 1/4", 1 1/2"	3/8" NPT	5.4" (138 mm)	9" (229 mm)	7" (178 mm)	6" (152 mm)	2.4" (60 mm)
210EZ	1 1/2", 2"	1/2" NPT	8.3" (211 mm)	11.3" (286 mm)	9.1" (232 mm)	8" (203 mm)	2.9" (75 mm)
210GZ	2 1/2", 3"	3/4" NPT	11.9" (302 mm)	16.5" (419 mm)	13.5" (343 mm)	11.8" (300 mm)	4.6" (116 mm)
210JZ	4"	3/4" NPT	18.4" (467 mm)	24.3" (616 mm)	18" (457 mm)	13.8" (349 mm)	5.4" (138 mm)

NOTE: Dimensions are maximums and to be used only as an aid in designing clearance for the valve.
Actual production dimensions may vary somewhat from those shown.

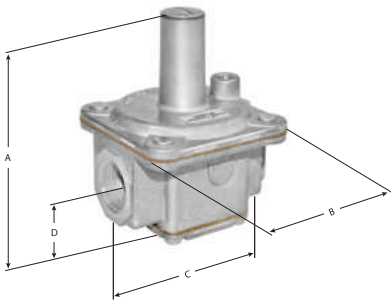

R400Z, R500Z, R600Z

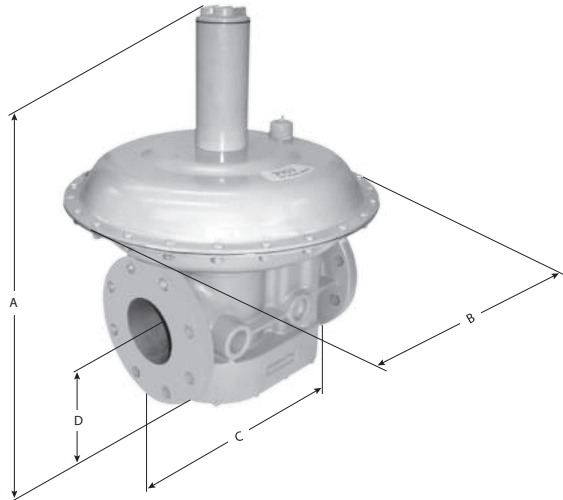

210JZ

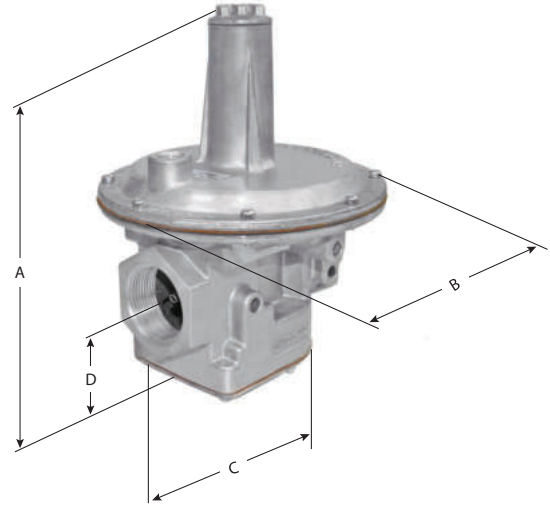

210DZ, 210EZ, 210GZ

Zero Governor Design

R400Z, R500Z, R600Z

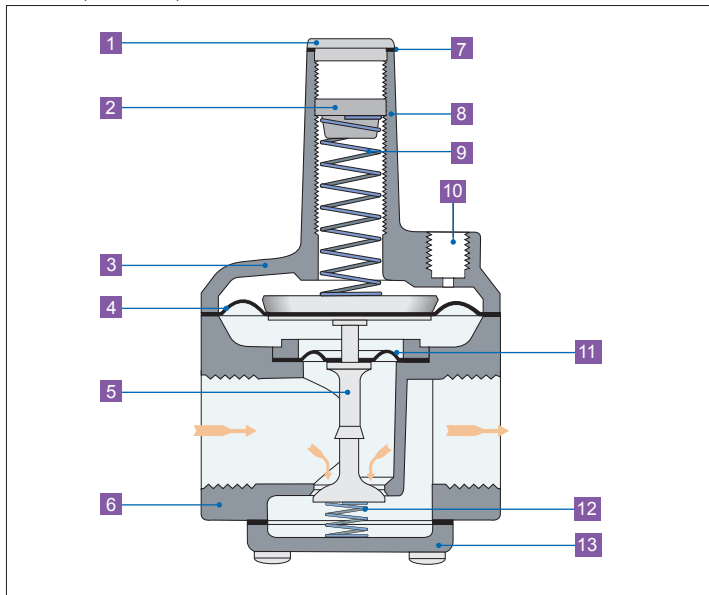

- 1 Seal Cap
- 2 Adjusting Screw
- 3 Top Housing
- 4 Regulating Diaphragm
- 5 Stem & Valve
- 6 Bottom Housing
- 7 Seal Cap Gasket
- 8 Stack
- 9 Spring
- 10 Vent Connection
- 11 Balancing Diaphragm
- 12 Counter Spring
- 13 Bottom Plate

210DZ, 210EZ, 210GZ, 210JZ

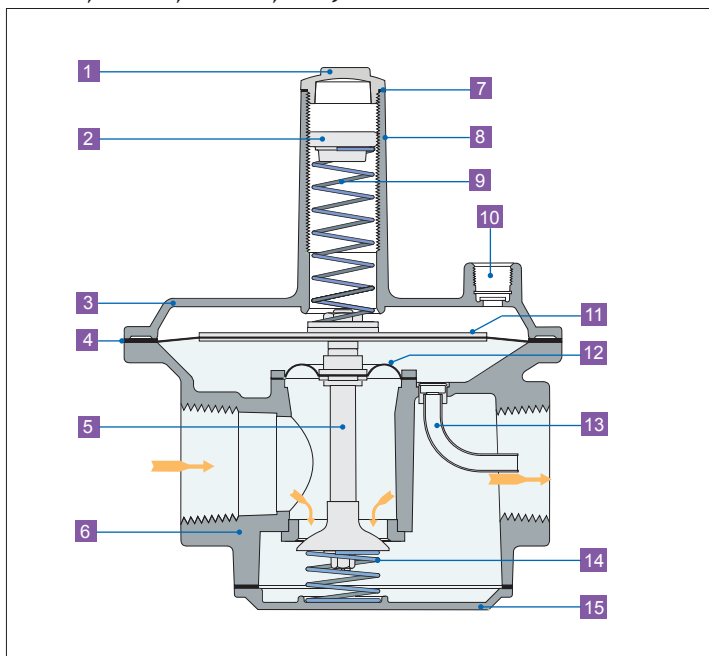

- 1 Seal Cap
- 2 Adjusting Screw
- 3 Top Housing
- 4 Regulating Diaphragm
- 5 Stem & Valve
- 6 Bottom Housing
- 7 Seal Cap Gasket
- 8 Stack
- 9 Spring
- 10 Vent Connection
- 11 Diaphragm Plates
- 12 Balancing Diaphragm
- 13 Sensing Tube
- 14 Counter Spring
- 15 Bottom Plate

NOTE: Diagrams are graphical representations only and may differ from actual product.