

Honeywell

SLATE™

Burner Control Module

R8001B2001

INSTALLATION INSTRUCTIONS





Scan for more information

Application

SLATE™ brings configurable safety and programmable logic together into one single platform. The platform can easily be customized for almost any requirement or application—offering virtually limitless development opportunities with far less complexity.

The R8001B2001 Burner Control module provides flame safeguard controls for a variety of applications within the SLATE system. It can be configured as a primary or programmer, semi-automatic or fully automatic.

Features

- Provides 24 VDC or 24 to 240 VAC flame safeguard
- Valve proving
- Parameters and behaviors that allow emulation of 7800 and SOLA Series flame safeguards
- Dual fuels capability
- Configurable safety
- Safety relay

Specifications

Electrical Ratings:

Voltage and Frequency:

- 24 VDC (\pm 15%),
- 24 VAC (\pm 15%), 50/60 Hz,
- 85-264 VAC, 50/60 Hz

Maximum Total Connected Load: 2000 VA

Fusing Total Connected Load: 15A Fast Blow, type SC or equivalent

Environmental Ratings

Ambient Temperature:

Operating: -20°F to +150°F (-29°C to +66°C).

Shipping: -40°F to +150°F (-40°C to +66°C).

Humidity: 95% continuous, noncondensing.

Vibration: 0.5G environment

Dimensions: See Fig. 1

Weight: 2 lb 1 oz (0.94 Kg)

Approvals

Underwriters Laboratories Inc. Listed, File: MP268

IRI Acceptable

Federal Communications Commission: Part 15, Class A

Must be mounted inside a grounded metal enclosure.

Mounting

DIN Rail (See Fig. 2)

Required Components

R8001A1001 SLATE Base Controller

R8001S9001 SLATE Sub-Base Module

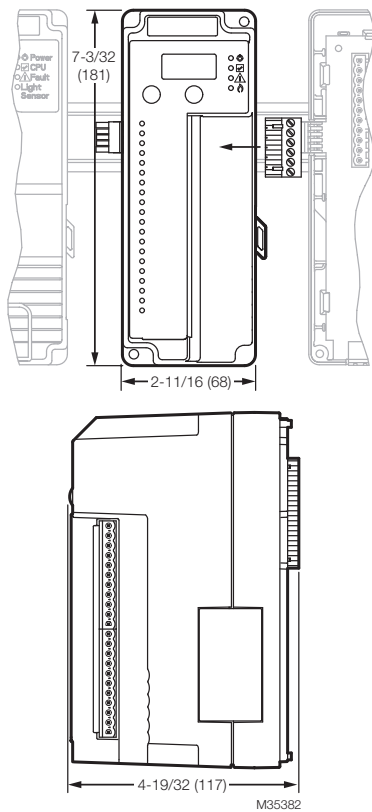

Fig. 1. Dimensions in in. (mm).

Principal Technical Features

The R8001B2001 SLATE Burner Control module provides the SLATE combustion system with flame safeguard capability.

LED Array

There are four LEDs on the front of the burner control module that provide quick identification of system status and problems. This status is broadcast to other modules on the platform bus in case they are affected by the inoperable module(s). See Table 1 for descriptions.





LED	Color	Description
 Power	No light	System does not have power
	Green	System has power
 CPU	Red	No wire sheet or problem with the wire sheet
	Green	Running
 Fault	Red	SLATE Burner Control Module has detected a fault
	No light	Running
 Flame	Yellow	Weak flame is detected
	No light	No flame is detected

Table 1. LED Descriptions.

LED Display

The SLATE system modules have a seven-segment, three-position LED display used for indicating the module number of the SLATE system. The LED colors indicate the terminal state as shown in Table 2.

Color	Description
Green	Terminal is on
Red	Fault
No light	Not in use

Table 2. Terminal LED Meanings.

Select and Reset Buttons

The SLATE Burner Control has a Select and Reset buttons located on the front of the module and beneath the segment display. The Reset button is used to clear a lockout and reset the module. The Select button is used to scroll through the segment display information.

There are also 22 LEDs for each of the burner control module terminals.

Installation



WARNING

Fire or Explosion Hazard

Can cause severe injury, death, or property damage.

Verification of safety requirements must be performed each time a control is installed on a burner to prevent possible hazardous burner operation.

When Installing This Product

1. Read these instructions carefully. Failure to follow them could damage the product or cause a hazardous condition.
2. Check the ratings given in the instructions and on the product to make sure the product is suitable for your application.
3. After installation is complete, check out the product operation as provided in these instructions.
4. The SLATE module must be mounted in an electrical enclosure with adequate clearance for servicing, installation and removal of modules.



WARNING

Electrical Shock Hazard.

Can cause severe injury, death or equipment damage.

1. Disconnect the power supply before beginning installation to prevent electrical shock and equipment damage. More than one power supply disconnect can be involved.

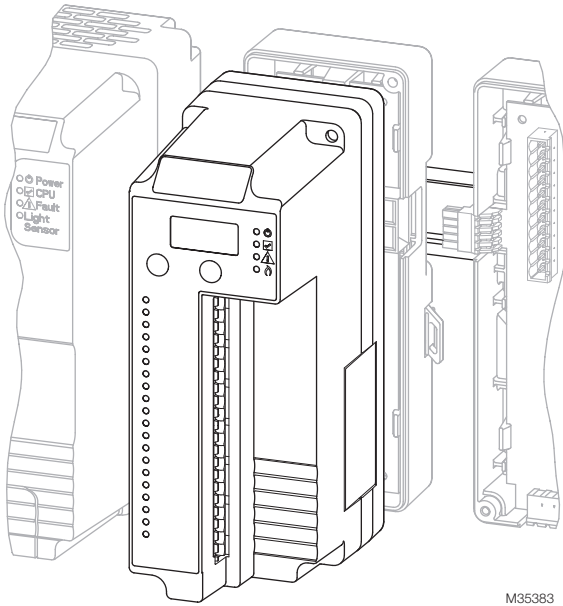

M35383

Fig. 2. Installing the Burner Control Module on the Sub-Base Module.

2. Wiring must comply with all applicable codes, ordinances and regulations.
3. Wiring must comply with NEC Class 1 (Line Voltage) wiring.
4. The R8001B2001 should not interfere with the proper safety operation of the controls, limits and interlocks it is monitoring. After installation, check each control, limit and interlock to ensure that it is operating properly. **DO NOT PLACE JUMPER WIRES ACROSS THE INSTALLATION CONTROLS, LIMITS AND INTERLOCKS.**

IMPORTANT

1. *This equipment generates, uses and can radiate radio frequency energy and, if not installed and used in accordance with these instructions, may cause interference for radio communications. It has been tested and found to comply with the limits of a Class A computing device of part 15 of FCC rules, which are designed to provide reasonable protection against such interference when operated in a commercial environment. Operation of this equipment in a residential area may cause interference; in which case, the user, at their own expense, may be required to take whatever measures are required to correct this interference.*
2. *This digital apparatus does not exceed the Class A limits for radio noise, set out in the Radio Interference Regulations of the Canadian Department of Communications.*
3. *Cable shield must be terminated to ground at both ends. If shielded cable is NOT used, use three-wire twisted cable.*

Wiring

 **WARNING**

Fire or Explosion Hazard
Can cause severe injury, death, or property damage.

Disconnect the power supply from the main disconnect before beginning installation to prevent electrical shock and equipment damage. More than one disconnect can be required.

Terminal	Description	Rating
1	Unused (reserved for future use)	---
2	Unused (reserved for future use)	---
3	Unused	---
4	K1 Relay Dry Contacts (Burner / Fan Motor)	9.8 FLA, 58.8 LRA @ 120VAC, 4A (0.5 PF), 20A inrush @ 240VAC

Terminal	Description	Rating
5	K1 Relay Dry Contacts	(see above)
6	Pilot Valve Hold (PVH)	24VDC (0.5mA), 24-240VAC (0.2mA)
7	Manual Open Switch (MOS)	24VDC (0.5mA), 24-240VAC (0.2mA)
8	Purge Position Proven (PPP)	24VDC (0.5mA), 24-240VAC (0.2mA)
9	Main Valve 2 (MV2)	120VAC (see Table 2), 4A (0.5 PF), 20A inrush @ 240VAC, 2A cont, 10A inrush @ 24VDC
10	Lightoff Position Proven (LPP)	24VDC (0.5mA), 24-240VAC (0.2mA)
11	Main Valve 1 (MV1)	120VAC (see Table 2), 4A (0.5 PF), 20A inrush @ 240VAC, 2A cont, 10A inrush @ 24VDC
12	Limit and Control Input (LCI) / Fuel (F) 2	24VDC (0.5mA), 24-240VAC (0.2mA)
13	Limit and Control Input (LCI) / Fuel (F) 1	24VDC (0.5mA), 24-240VAC (0.2mA)
14	Pre-Ignition Interlocks (PII)	24VDC (0.5mA), 24-240VAC (0.2mA)
15	Pilot Valve (PV)	120VAC (see Table 2), 4A (0.5 PF), 20A inrush @ 240VAC, 1A cont, 5A inrush @ 24VDC
16	Interrupted Air Switch (IAS)	24VDC (0.5mA), 24-240VAC (0.2mA)
17	Ignition (IGN)	120VAC (see Table 2), 4A (0.2 PF) @ 240VAC, 1A cont, 5A inrush @ 24VDC
18	Valve Proving Switch (VPS)	24VDC (0.5mA), 24-240VAC (0.2mA)

Terminal	Description	Rating
19	Lockout Interlocks (ILK)	24VDC (0.5mA), 24-240VAC (0.2mA)
20	Vref+	24VDC (0.1mA), 24VAC (0.1mA), 85-264VAC (0.2mA)
21	Unused	---
22	Vref-	(see Vref+ above)

Note: only one voltage can be used per module (same at all terminals).

Table 3. Terminal Ratings.

Combination	Pilot Valve	Ignition	MV1 & MV2
1	C	no load	E
2	B	no load	E
3	E	A	E
4	D	A	E
5	D	A	D
Load Table Key			
A	4.5 A Ignition		
B	4.5 A plus 50 VA Pilot Duty		
C	180 VA Ign plus motor valves with: 660 VA inrush, 360 VA open, 250 VA hold		
D	2 A Pilot Duty		
E	65 VA Pilot Duty plus motor valves with: 3850 VA inrush, 700 VA open, 250 VA hold		

Table 4. Combinations for PV, IGN, MV1 & MV2 Terminals.

Application	Recommended Wire Size	Recommended Part Numbers
Line voltage terminals	14, 16 or 18 AWG copper conductor, 600 volt insulation, moisture-resistant wire.	TTW60C, THW75C, THHN90C
Communication Lines	22 AWG two-wire twisted pair with ground, or five-wire.	Belden 8723 shielded cable or equivalent.
Other terminals	18 AWG wire insulated for voltages and temperatures for given application.	TTW60C, THW75C, THHN90C

Table 5. Recommended Wire Sizes and Part Numbers.

Recommended Grounding Practices

Use an Earth ground or a signal ground as described below.

Earth ground (Base, Rectification Flame Amp Module, other modules optional)

1. Use to provide a connection between the base and the control panel of the equipment. Earth ground must be capable of conducting enough current to blow the breaker in the event of an internal short circuit.
2. Use wide straps or brackets to provide minimum length, maximum surface area ground conductors. If a leadwire is required, use 14 AWG copper wire.
3. Make sure that mechanically tightened joints along the ground path are free of nonconductive coatings and protected against corrosion on mating surfaces.

Signal ground

Note the 18V system ground is not electrically connected to earth ground. Follow local codes and appliance recommendations to determine if this should be connected to earth ground.

Recommended wire routing of leadwires

- Do not run high voltage ignition transformer wires in the same conduit with the flame detector or data lines.
- Do not route flame detector or data lines in conduit with line voltage circuits.
- Enclose flame detector leadwires without armor cable in metal cable or conduit.
- Follow directions in flame detector instructions.

Be sure loads do not exceed the terminal ratings. Refer to the labels or terminal ratings in Table 3.

The SLATE system must be mounted in an electrical enclosure. When mounting in an electrical enclosure, provide adequate clearance for servicing, installation and removal of SLATE modules.

Maximum wire length:

- The maximum leadwire length is 300 feet to terminal inputs (Control, Running/Lockout Interlock)
- For remote reset leadwires, maximum length to remote pushbutton is 1000 feet.
- For Remote Bus data lines, maximum cable length depends on the number of modules connected, the noise conditions and the cable used. The maximum of all interconnecting wires is 4000 feet.

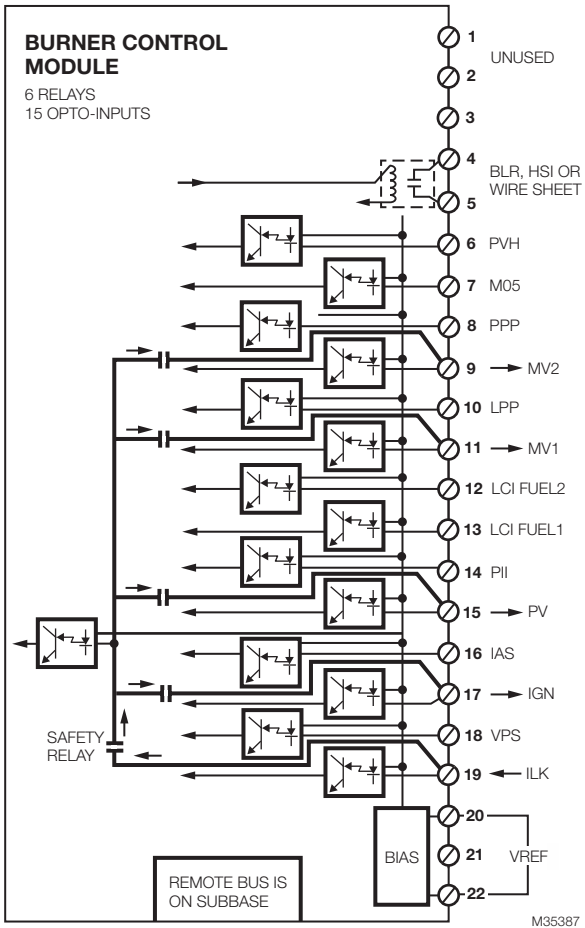

Fig. 3. Wiring diagram for Burner Control Module.



32-00010-01

For more information on the R8001B2001 and the entire SLATE system please refer to the SLATE User Guide located on our website at <http://www.combustion.honeywell.com/SLATE>

Honeywell

Automation and Control Solutions

Honeywell International Inc.
1985 Douglas Drive North
Golden Valley, MN 55422
customer.honeywell.com

® U.S. Registered Trademark.
© 2014 Honeywell International Inc.
32-00010—01 M.S. 12-14
Printed in U.S.A.