

GB **Light oil burners**

Progressive two-stage or modulating operation



CODE	MODEL	TYPE
20169338	RL 55/M BLU	969 T
20169330	RL 85/M BLU	952 T1



Translation of the original instructions

1	Declarations	3
2	Information and general warnings	4
2.1	Information about the instruction manual	4
2.1.1	Introduction	4
2.1.2	General dangers	4
2.1.3	Other symbols	4
2.1.4	Delivery of the system and the instruction manual	5
2.2	Guarantee and responsibility	5
3	Safety and prevention	6
3.1	Introduction	6
3.2	Personnel training	6
4	Technical description of the burner	7
4.1	Burner designation	7
4.2	Models available	7
4.3	Technical data	8
4.4	Electrical data	8
4.4.1	Weight - approximate measurements	8
4.5	Overall dimensions	9
4.6	Standard equipment	9
4.7	Firing rates	10
4.8	Test boiler	11
4.9	Commercial boilers	11
4.9.1	Smoke ducts	11
4.10	Burner description	12
4.11	Electrical panel description	13
4.12	Control box RFGO-A23	14
4.13	Servomotor (SQN31...)	15
5	Installation	16
5.1	Notes on safety for the installation	16
5.2	Handling	16
5.3	Preliminary checks	16
5.4	Operating position	17
5.5	Boiler plate	17
5.6	Blast tube length	17
5.7	Securing the burner to the boiler	18
5.8	Electrode positions	18
5.9	Nozzle installation	19
5.9.1	Nozzle selection	19
5.10	Nozzle assembly	19
5.11	Combustion head adjustment	19
5.12	Light oil supply	20
5.12.1	Hydraulic connections	21
5.12.2	Hydraulic circuit diagram	21
5.13	Pump	22
5.13.1	Technical data	22
5.13.2	Priming pump	22
5.14	Electrical connections	23
5.14.1	Supply cables and external connections passage	24
5.15	Calibration of the thermal relay	24
5.16	Motor rotation	24
6	Start-up, calibration and operation of the burner	25
6.1	Notes on safety for the first start-up	25
6.2	Burner ignition	25
6.3	Operation	25
6.3.1	MAX output	25
6.3.2	MIN output	26
6.3.3	Intermediate outputs light oil/air delivery adjustment	26
6.3.4	Servomotor	27
6.4	Pressure switch adjustment	27
6.4.1	Oil pressure switch	27
6.5	Operation sequence of the burner	28
6.5.1	Burner start-up	28
6.5.2	Steady state operation	28
6.5.3	Ignition failure	28
6.5.4	Burner flame goes out during operation	28
6.6	Final checks	28
7	Maintenance	29
7.1	Notes on safety for the maintenance	29
7.2	Maintenance programme	29
7.2.1	Maintenance frequency	29

7.2.2	Checking and cleaning	29
7.2.3	Safety components	30
7.3	Opening the burner	30
7.4	Closing the burner	31
8	LED indicator and special function	32
8.1	Description of LED lamps	32
8.2	Check mode function	32
8.3	Flame control lock-out or emergency stop condition	32
8.4	LED lamps: burner operating status	33
9	Problems - Causes - Remedies signalled by LED indicators	34

1 Declarations

Declaration of conformity in accordance with ISO / IEC 17050-1

Manufacturer:	RIELLO S.p.A.		
Address:	Via Pilade Riello, 7 37045 Legnago (VR)		
Product:	Light oil burners		
Model and type:	RL 55/M BLU	969 T	
	RL 85/M BLU	952 T1	
These products are in compliance with the following Technical Standards:			
EN 267			
EN 12100			
and according to the European Directives:			
MD	2006/42/CE	Machine Directive	
LVD	2014/35/EU	Low Voltage Directive	
EMC	2014/30/EU	Electromagnetic Compatibility	

The quality is guaranteed by a quality and management system certified in accordance with ISO 9001:2015.

Manufacturer's Declaration

RIELLO S.p.A. declares that the following products comply with the NOx emission limits specified by German standard "1. BImSchV revision 26.01.2010".

Product	Type	Model	Output
Light oil burner	969 T	RL 55/M BLU	190 - 712 kW
	952 T1	RL 85/M BLU	223 - 1023 kW

Legnago, 21.04.2018

General Manager
RIELLO S.p.A. - Burners Department
Eng. U. Ferretti

Research and Development Director
RIELLO S.p.A. - Burners Department
Eng. F. Comencini

2 Information and general warnings

2.1 Information about the instruction manual

2.1.1 Introduction

The instruction manual supplied with the burner:

- is an integral and essential part of the product and must not be separated from it; it must therefore be kept carefully for any necessary consultation and must accompany the burner even if it is transferred to another owner or user, or to another system. If the manual is lost or damaged, another copy must be requested from the Technical Assistance Centre of the area;
- is designed for use by qualified personnel;
- offers important indications and instructions relating to the installation safety, start-up, use and maintenance of the burner.

Symbols used in the manual

In some parts of the manual you will see triangular DANGER signs. Pay great attention to these, as they indicate a situation of potential danger.

2.1.2 General dangers

The **dangers** can be of **3 levels**, as indicated below.



Maximum danger level!
This symbol indicates operations which, if not carried out correctly, cause serious injury, death or long-term health risks.



This symbol indicates operations which, if not carried out correctly, may cause serious injury, death or long-term health risks.



This symbol indicates operations which, if not carried out correctly, may cause damage to the machine and/or injury to people.

2.1.3 Other symbols



DANGER: LIVE COMPONENTS
This symbol indicates operations which, if not carried out correctly, lead to electric shocks with lethal consequences.



DANGER: FLAMMABLE MATERIAL
This symbol indicates the presence of flammable materials.



DANGER: BURNING
This symbol indicates the risks of burns due to high temperatures.



DANGER: CRUSHING OF LIMBS
This symbol indicates the presence of moving parts: danger of crushing of limbs.



WARNING: MOVING PARTS
This symbol indicates that you must keep limbs away from moving mechanical parts; danger of crushing.



DANGER: EXPLOSION
This symbol signals places where an explosive atmosphere may be present. An explosive atmosphere is defined as a mixture - under atmospheric conditions - of air and flammable substances in the form of gases, vapours, mist or dust in which, after ignition has occurred, combustion spreads to the entire unburned mixture.



PERSONAL PROTECTION EQUIPMENT
These symbols indicate the equipment that must be worn and kept by the operator for protection against threats against safety and/or health while at work.



OBLIGATION TO ASSEMBLE THE COVER AND ALL THE SAFETY AND PROTECTION DEVICES
This symbol signals the obligation to reassemble the cover and all the safety and protection devices of the burner after any maintenance, cleaning or checking operations.



ENVIRONMENTAL PROTECTION
This symbol gives indications for the use of the machine with respect for the environment.



IMPORTANT INFORMATION
This symbol indicates important information that you must bear in mind.

- This symbol indicates a list.

Abbreviations used

Ch.	Chapter
Fig.	Figure
Page	Page
Sec.	Section
Tab.	Table

2.1.4 Delivery of the system and the instruction manual

When the system is delivered, it is important that:

- the instruction manual is delivered to the user by the system manufacturer, with the recommendation to keep it in the room where the heat generator is to be installed.
- The instruction manual shows:
 - the serial number of the burner;

.....

- the address and telephone number of the nearest Assistance Centre;

.....

- The system supplier must carefully inform the user about:
 - the use of the system;
 - any further tests that may be required before activating the system;
 - maintenance, and the need to have the system checked at least once a year by a representative of the manufacturer or another specialised technician.
 To ensure a periodic check, the manufacturer recommends the drawing up of a Maintenance Contract.

2.2 Guarantee and responsibility

The manufacturer guarantees its new products from the date of installation, in accordance with the regulations in force and/or the sales contract. At the moment of the first start-up, check that the burner is integral and complete.



Failure to observe the information given in this manual, operating negligence, incorrect installation and carrying out of non authorised modifications will result in the annulment by the manufacturer of the guarantee that it supplies with the burner.

In particular, the rights to the guarantee and the responsibility will no longer be valid, in the event of damage to things or injury to people, if such damage/injury was due to any of the following causes:

- incorrect installation, start-up, use and maintenance of the burner;
- improper, incorrect or unreasonable use of the burner;
- intervention of unqualified personnel;
- carrying out of unauthorised modifications on the equipment;
- use of the burner with safety devices that are faulty, incorrectly applied and/or not working;
- installation of untested supplementary components on the burner;
- powering of the burner with unsuitable fuels;
- faults in the fuel supply system;
- continuation of use of the burner when a fault has occurred;
- repairs and/or overhauls incorrectly carried out;
- modification of the combustion chamber with inserts that prevent the regular development of the structurally established flame;
- insufficient and inappropriate surveillance and care of those burner components most likely to be subject to wear and tear;
- use of non-original components, including spare parts, kits, accessories and optional;
- force majeure.

The manufacturer furthermore declines any and every responsibility for the failure to observe the contents of this manual.

3 Safety and prevention

3.1 Introduction

The burners have been designed and built in compliance with current regulations and directives, applying the known technical safety rules and envisaging all the potential danger situations.

It is necessary, however, to bear in mind that the imprudent and clumsy use of the equipment may lead to situations of death risk for the user or third parties, as well as the damaging of the burner or other items. Inattention, thoughtlessness and excessive confidence often cause accidents; the same applies to tiredness and sleepiness.

It is a good idea to remember the following:

- The burner must only be used as expressly described. Any other use should be considered improper and therefore dangerous.

Specifically:

it can be applied to boilers operating with water, steam, diathermic oil, and to other uses expressly named by the manufacturer;

the type and pressure of the fuel, the voltage and frequency of the electrical power supply, the minimum and maximum deliveries for which the burner has been regulated, the pressurisation of the combustion chamber, the dimensions of the combustion chamber and the ambient temperature must all be within the values indicated in the instruction manual.

- Modification of the burner to alter its performance and destinations is not allowed.
- The burner must be used in exemplary technical safety conditions. Any disturbances that could compromise safety must be quickly eliminated.
- Opening or tampering with the burner components is not allowed, apart from the parts requiring maintenance.
- Only those parts envisaged by the manufacturer can be replaced.



ATTENTION

The manufacturer guarantees safety and proper operation only if all burner components are intact and correctly positioned.

3.2 Personnel training

The user is the person, body or company that has acquired the machine and intends to use it for the specific purpose. He is responsible for the machine and for the training of the people working around it.

The user:

- undertakes to entrust the machine exclusively to suitably trained and qualified personnel;
- undertakes to inform his personnel in a suitable way about the application and observance of the safety instructions. With that aim, the user undertakes to ensure that everyone knows the use and safety instructions for his own duties;
- Personnel must observe all the danger and caution indications shown on the machine.
- Personnel must not carry out, on their own initiative, operations or interventions that are not within their province.
- Personnel must inform their superiors of every problem or dangerous situation that may arise.
- The assembly of parts of other makes, or any modifications, can alter the characteristics of the machine and hence compromise operating safety. The manufacturer therefore declines any and every responsibility for any damage that may be caused by the use of non-original parts.

In addition:



- must take all the measures necessary to prevent unauthorised people gaining access to the machine;
- the user must inform the manufacturer if faults or malfunctioning of the accident prevention systems are noticed, along with any presumed danger situation;
- personnel must always use the personal protective equipment envisaged by legislation and follow the indications given in this manual.

4 Technical description of the burner

4.1 Burner designation

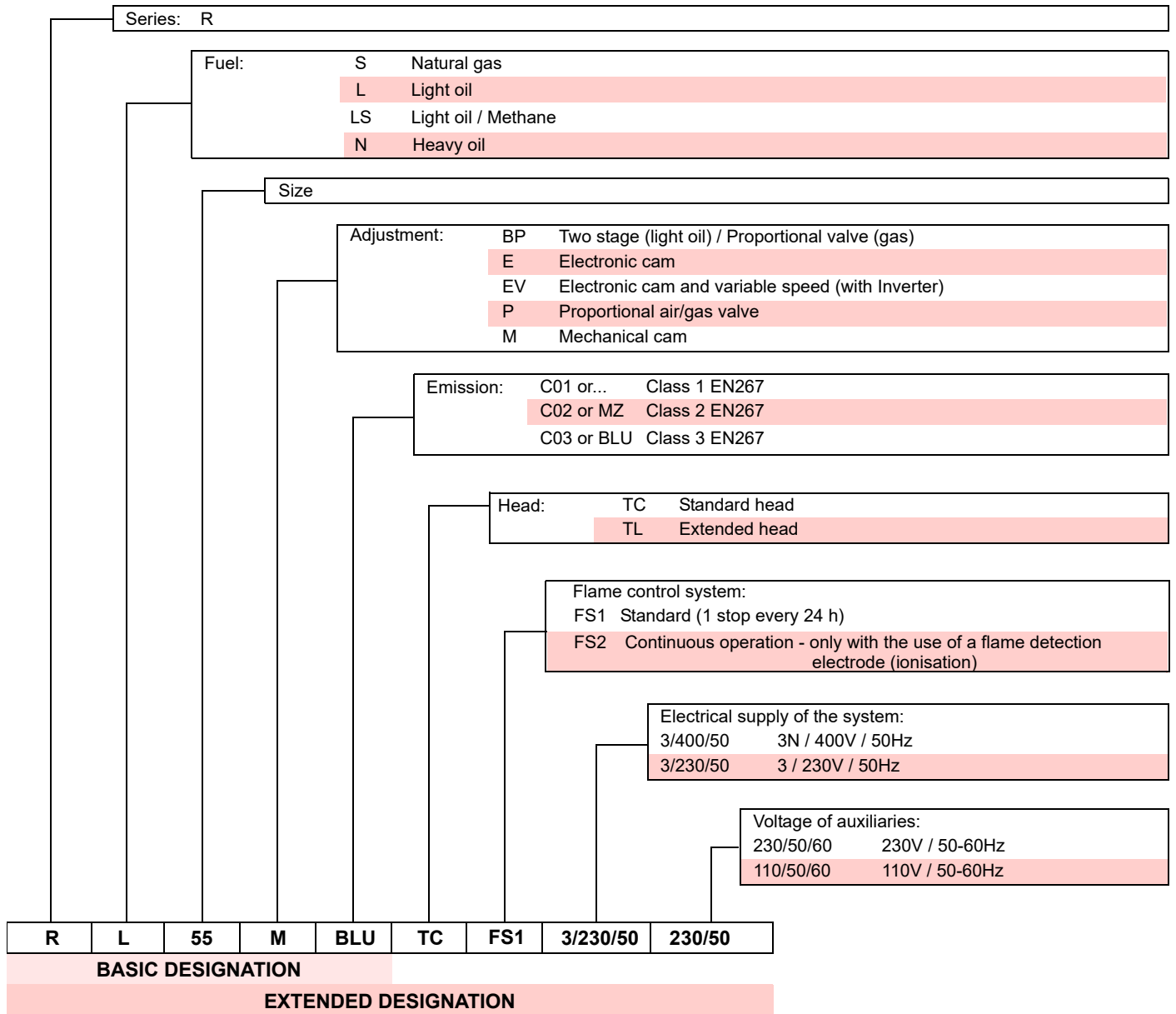

4.2 Models available

Designation	Voltage	Start-up	Code
RL 55/M BLU	3/230-400/50	Direct	20169338
RL 85/M BLU	3/230-400/50	Direct	20169330

4.3 Technical data

Model			RL 55/M BLU	RL 85/M BLU
Type			969 T	952 T1
Output (1)	Max.	kW	356 - 712	594 - 1023
		Mcal/h	307 - 614	512 - 882
	Min.	kg/h	30 - 60	50 - 86.2
		kW	190 - 356	223 - 594
		Mcal/h	164 - 307	192 - 512
		kg/h	16 - 30	18.8 - 50
Fuel			Light oil	
- Net calorific value		kWh/kg	11.86	
		Mcal/kg	10.2 (10.200 kcal/kg)	
- Density		kg/dm ³	0.82 - 0.85	
- viscosity at 20 °C		mm ² /s	max 6 (1,5 °E - 6 cSt)	
Operation			<ul style="list-style-type: none"> • Intermittent (min. 1 stop every 24 hours). • Progressive two-stage (modulating by kit). 	
Nozzle		number	1 (nozzle with return line)	
Standard applications			Boilers: water, steam, diathermic oil	
Ambient temperature		°C	0 - 40	
Combustion air temperature		°C max	60	
Pump output (at 20 bar)		kg/h	163	
pressure range		bar	10 - 21	
fuel temperature		°C max	90	
Protection level			IP 44	
Noise level (2)				
Sound pressure		dBA	78.5	78.5
Sound power			89.5	89.5

Tab. A

- (1) Reference conditions: Ambient temperature 20°C - Fuel temperature 15°C - Barometric pressure 1013 mbar - Altitude 0 m a.s.l.
- (2) Sound pressure measured in manufacturer's combustion laboratory, with burner operating on test boiler and at maximum output. The sound power is measured using the "Free Field" method, required by the EN 15036 standard, and according to an "Accuracy: Category 3" measurement, as described in EN ISO 3746.

4.4 Electrical data

Model		RL 55/M BLU	RL 85/M BLU
Electrical power supply	V	230 - 400 ~ +/-10%	
	Hz	50 - three-phase	
Electrical motor IE3	rpm	2910	2890
	W	1800	2200
	V	230/400	230/400
	A	6.9/4	8/4.6
Ignition transformer	V1 - V2	230 V - 2 x 5 kV	
	I1 - I2	1.9 A - 30 mA	
Absorbed electrical power	W max	2500	2900

Tab. B

4.4.1 Weight - approximate measurements

The weight of the burner complete with its packaging is shown in Tab. C.

Model	kg
RL 55/M BLU	65
RL 85/M BLU	70

Tab. C

4.5 Overall dimensions

The dimensions of the burner are given in Fig. 1.
 Bear in mind that inspection of the combustion head requires the burner to be opened and the rear part drawn back on the slide bars.

The maximum dimensions of the open burner are indicated by the value I.

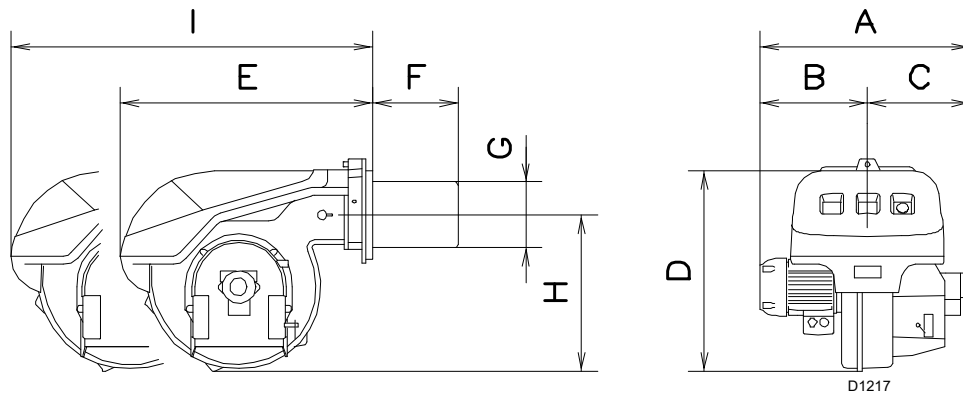

Fig. 1

mm	A	B	C	D	E	F	G	H	I
RL 55/M BLU	705	338	367	555	680	365	189	430	951
RL 85/M BLU	705	338	367	555	680	365	189	430	951

Tab. D

4.6 Standard equipment

The burner is supplied complete with:

- Flexible hoses No. 2
- Seal for flexible hoses No. 2
- Nipples for flexible hoses No. 2
- Thermal flange gasket No. 1
- M12x35 screws to secure the burner flange to the boiler. . No. 4
- Spare parts list No. 1
- Instructions. No. 1

4.7 Firing rates

During operation, burner output varies between:

- a **MINIMUM OUTPUT**: area A;
- a **MAXIMUM OUTPUT**: area B.

Diagrams (Fig. 2):

Horizontal axis: Burner output

Vertical axis: Pressure in combustion chamber

The work point is found by drawing a vertical line from the required output and an horizontal line from the corresponding pressure in the combustion chamber.

The intersection of these two lines is the work point which must lie within area A for the MINIMUM output and area B for the MAXIMUM output.



The FIRING RATE was obtained with an ambient temperature of 20°C and a barometric pressure of 1013 mbar (approx. 0m above sea level), with the combustion head adjusted as shown on page 19.

RL 55/M BLU

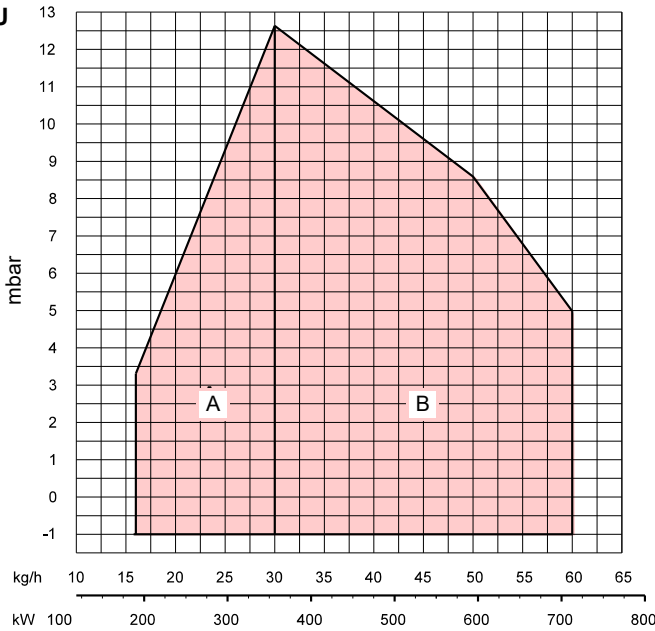

RL 85/M BLU

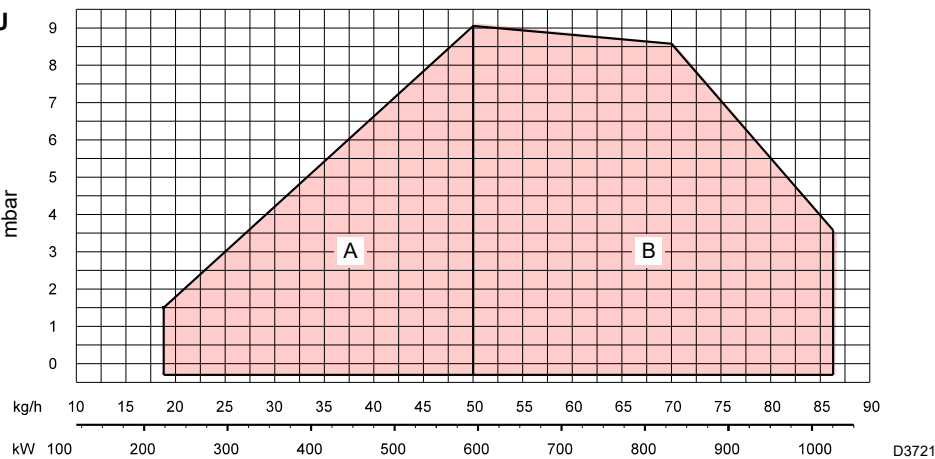

Fig. 2

4.8 Test boiler

The burner/boiler combination does not pose any problems if the boiler is EC approved and its combustion chamber dimensions are similar to those indicated in the diagram (Fig. 3).

If the burner must be combined with a boiler that has not been EC approved and/or its combustion chamber dimensions are clearly smaller than those indicated in the diagram, consult the manufacturer.

The firing rates were obtained in special test boilers, according to EN 267 standard.

In Fig. 3 you can see the diameter and length of the test combustion chamber.

Example:

Output 65 kg/h: diameter 60 cm - length 2 m.

MODULATING RATIO

The modulating ratio, obtained in test boilers in accordance with the norm (EN 267 for light oil) is 2:1.

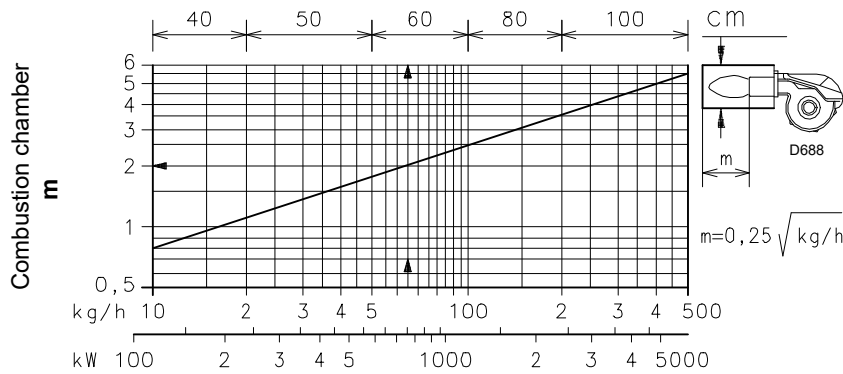

Fig. 3

4.9 Commercial boilers



Burners RL 55-85/M BLU have been designed only for combustion chambers with minimum dimensions in compliance with norm EN 304, with flue gases coming out from the bottom, for example three flue passes (not flue gas inversion boilers), accessible through the door.

Maximum thickness of the boiler's front panel: 250 mm, see Fig. 4.

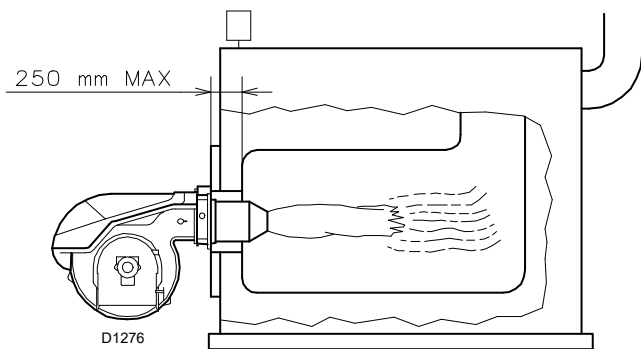

Fig. 4

4.9.1 Smoke ducts

Some norms provide indications for the correct installation of the smoke ducts, which connect the boiler to the flue pipe or the chimney.

At any rate we suggest following these indications:

- The smoke ducts must always have only an updraught;
- changes in direction are allowed only by using curved elements;
- The angle formed between the axis of the terminal entrance section and the axis of the flue pipe or the chimney must be greater than 45°.

4.10 Burner description

- 1 Ignition electrodes
- 2 Flame sensor
- 3 Combustion head
- 4 Screw for combustion head adjustment
- 5 Screw for fixing fan to flange
- 6 Oil pressure switch
- 7 Nozzle return pressure gauge
- 8 Pump
- 9 Air inlet to fan
- 10 Air damper
- 11 Fan pressure test point
- 12 Boiler fixing flange
- 13 Flame stability disc
- 14 Servomotor, controls the fuel flow rate variator and the air damper.
- 15 Slide bars for opening the burner and inspecting the combustion head
- 16 Electrical motor
- 17 Extensions for slide bars 15)
- 18 Electrical control box with lockout pilot light and reset button
- 19 Flame inspection window
- 20 Valve unit with nozzle return line pressure variator

Two types of burner lockout may occur:

Control box lockout: if the control box 18)(Fig. 5) push-button lights up, it indicates that the burner is in lockout.

Press the push-button to reset.

Motor lockout: release by pressing the push-button on thermal relay 2)(Fig. 6 on page 13).

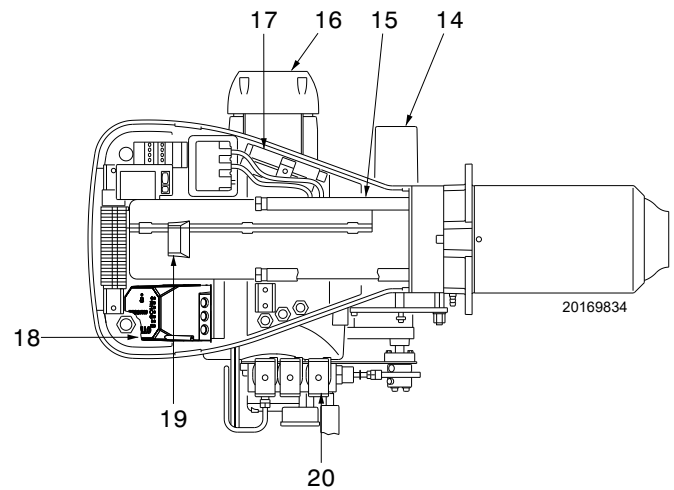
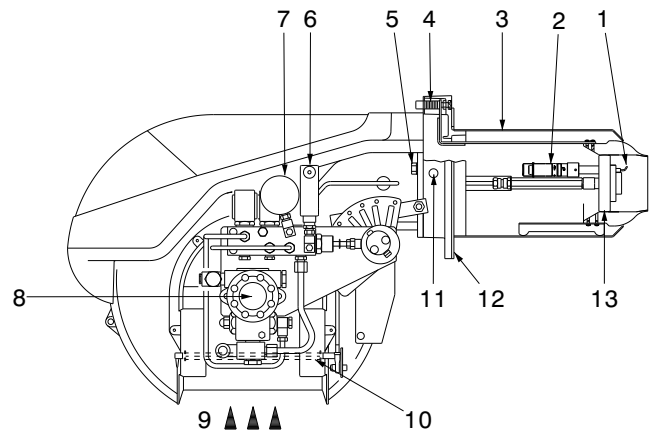

Fig. 5

4.11 Electrical panel description

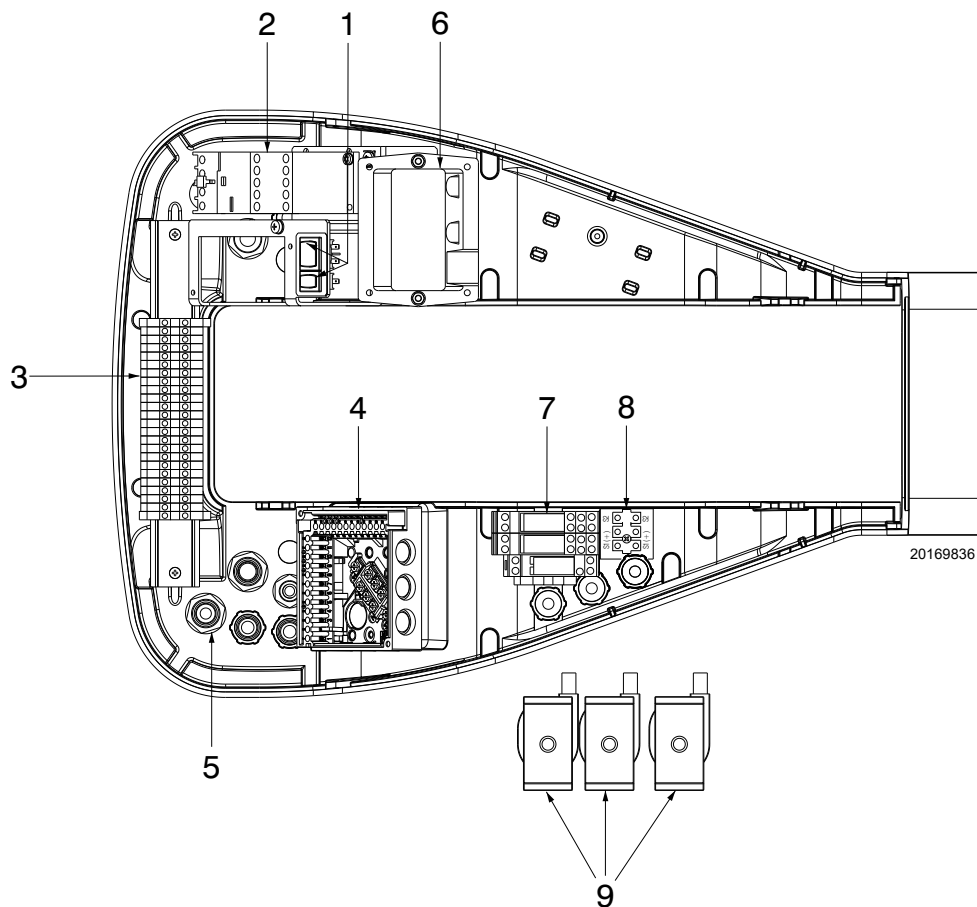

Fig. 6

- 1 Power switch for:
automatic - manual - off operation
Button for:
power increase - power reduction
- 2 Motor contactor and thermal relay with reset button
- 3 Terminal board for electric connection
- 4 Control box base
- 5 Cable grommets for external connections (to be carried out by the installer)
- 6 Ignition transformer
- 7 Relay
- 8 Terminal board for flame sensor
- 9 Oil valve coils

4.12 Control box RFGO-A23

Important notes



ATTENTION

To avoid accidents, material or environmental damage, observe the following instructions!

The control box is a safety device! Avoid opening or modifying it, or forcing its operation. The Manufacturer cannot assume any responsibility for damage resulting from unauthorised work!

- All interventions (assembly and installation operations, assistance, etc.) must be carried out by qualified personnel.
- Before modifying the wiring in the control box connection area, fully disconnect the system from the power supply (omnipolar separation).
- Protection against electrocution from the control box and all connected electric components is obtained with the correct assembly.
- Before any intervention (assembly and installation operations, assistance, etc.), ensure the wiring is in order and that the parameters are correctly set, then make the safety checks.
- Falls and collisions can negatively affect the safety functions. In this case, the control box must not be operated, even if it displays no evident damage.

For safety and reliability, comply with the following instructions:

- avoid conditions that can favour the development of condensate and humidity. Otherwise, before switching on again, make sure that the entire control box is perfectly dry!
- Static charges must be avoided since they can damage the control box's electronic components when touched.

Use

The control box is a control and supervision system of medium and large capacity forced draught burners.

If used with the flame detection electrode the system can operate continuously whereas, with the use of UV sensors it operates intermittently with stop and restart request at least once every 24h.

Installation notes

- Make sure that the electrical wiring inside the boiler complies with national and local safety regulations.
- Do not confuse the powered conductors with the neutral ones.
- Ensure that spliced wires cannot get into contact with neighbouring terminals. Use adequate ferrules.
- Arrange the H.V. ignition cables separately, as far as possible from the control box and the other cables.
- When wiring the unit, make sure that AC 230 V mains voltage cables are run strictly separate from extra low-voltage cables to avoid risks of electrical shock hazard.



20152163

Fig. 7

Technical data

Mains voltage	AC 230 V -15 % / +10 %
Mains frequency	50 / 60 Hz
Primary fuse (external)	Refer to the electric system
Weight	approx. 1.1 kg
Power absorption	approx. AC 7 VA
Protection level	IP40
Safety class	II
Environmental conditions	
Operation	DIN EN 60721-3-1
Climatic conditions	Class 1K2
Mechanical conditions	Class 1M2
Temperature range	-50...+85 °C
Humidity	< 90% RH (non-condensing)

Tab. E

Electrical wiring of the flame detector

It is important for signal transmission to be almost totally free of any disturbances or loss:

- Always separate the detector cables from the other cables:
 - The capacitive reactance of the line reduces the size of the flame signal.
 - Use a separate cable.
- Respect the allowed cable lengths.
- The ionisation probe is not protected against the risk of electrocution. When connected to the electricity supply, the ionisation probe must be protected against any accidental contact.
- Position the ignition electrode and the ionisation probe so that the ignition spark cannot form an arc on the probe (risk of electric overcharge).

4.13 Servomotor (SQN31...)

Important notes



To avoid accidents, material or environmental damage, observe the following instructions!

Avoid opening, modifying or forcing the actuators.

- All interventions (assembly and installation operations, assistance, etc.) must be carried out by qualified personnel.
- Before modifying the wiring in the connection area of the servomotor, fully disconnect the burner control device from the power supply (omnipolar separation).
- To avoid the risk of electrocution, protect the connection terminals in a suitable manner and correctly fix the cover.
- Check the wiring is in order.
- Falls and collisions can negatively affect the safety functions. In this case, the servomotor must not be operated, even if it displays no evident damage.

Assembly notes

- Check the relevant national safety standards are respected.
- When assembling the servomotor and connecting the damper, the gears can be disengaged by means of a lever, allowing the drive shaft to be easily adjusted in both directions of rotation.



20160309

Fig. 8

Technical data

Operating voltage	AC 220...240 V - 15% / +10% AC 100...110 V - 15% / +10%
Mains frequency	50...60 Hz ± 6%
Switching capacity of auxiliary devices and limit switches	10 (3) A, AC 24...250 V
Angle positioning	up to 160° (full scale)
Assembly position	option
Protection level	IP 54, DIN 40050
Safety class	I
Weight	approx. 0.8 kg
Actuator motor	synchronous motor
Power absorption	6.5 VA
Environmental conditions:	
Operation	DIN EN 60 721-3-1
Climatic conditions	Class 1K2
Mechanical conditions	Class 1M2
Temperature range	-20...+60°C
Humidity	< 95% RH

Tab. F

5 Installation

5.1 Notes on safety for the installation

After carefully cleaning all around the area where the burner is to be installed, and arranging for the environment to be illuminated correctly, proceed with the installation operations.



All the installation, maintenance and disassembly operations must be carried out with the electricity supply disconnected.



The installation of the burner must be carried out by qualified personnel, as indicated in this manual and in compliance with the standards and regulations of the laws in force.



The combustion air inside the boiler must be free from hazardous mixes (e.g.: chloride, fluoride, halogen); if present, it is highly recommended to carry out cleaning and maintenance more frequently.

5.2 Handling

The burner packaging includes a wooden platform, it is therefore possible to handle the burner (still packaged) with a pallet truck or fork lift truck.



Burner handling operations can be highly dangerous if not carried out with the greatest attention: distance unauthorised personnel, check integrity and suitability of the means available. Check also that the area in which you are working is empty and that there is an adequate escape area (i.e. a free, safe area to which you can quickly move if the burner should fall). During handling, keep the load at no more than 20-25 cm from the ground.



After positioning the burner near the installation point, correctly dispose of all residual packaging, separating the various types of material.



Before proceeding with the installation operations, carefully clean all around the area where the burner will be installed.

5.3 Preliminary checks

Checking the consignment



After removing all the packaging, check the integrity of the contents. In the event of doubt, do not use the burner; contact the supplier.



The packaging elements (wooden cage or cardboard box, nails, clips, plastic bags, etc.) must not be abandoned as they are potential sources of danger and pollution; they should be collected and disposed of in the appropriate places.

- Check the identification label of the burner, showing:
- the model (see **A** in Fig. 9) and the type of burner (**B**);
 - the year of manufacture, in cryptographic form (**C**);
 - the serial number (**D**);
 - the absorbed electrical power (**E**);
 - the types of fuel used and the relative supply pressures **F**;
 - the minimum and maximum possible output data of the burner (**G**) (see Firing rate).

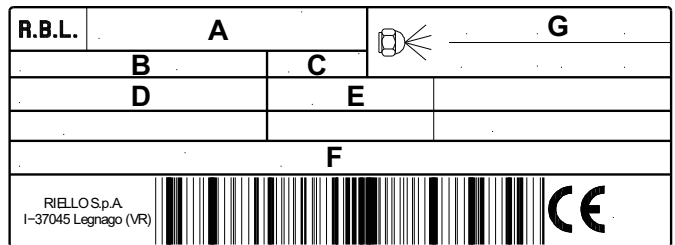

S9762

Fig. 9



A burner label that has been tampered with, removed or is missing, along with anything else that prevents the definite identification of the burner makes any installation or maintenance work difficult.

5.4 Operating position



- The burner is set up to operate only in positions **1, 2, 3** and **4** (Fig. 10).
- Installation **1** is preferable, as it is the only one that allows the maintenance operations as described in this manual.
- Installations **2, 3** and **4** permit operation but make maintenance and inspection of the combustion head more difficult.



- Any other position could compromise the correct operation of the appliance.
- The installation **5** is prohibited for safety reasons.

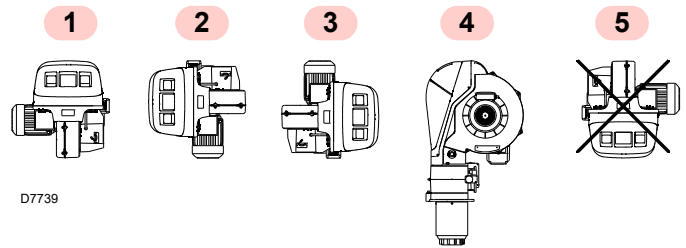

Fig. 10

5.5 Boiler plate

Pierce the closing plate of the combustion chamber, as in (Fig. 11). The position of the threaded holes can be marked using the thermal insulation screen supplied with the burner.

mm	A	B	C
RL 55/M BLU	195	275-325	M 12
RL 85/M BLU	195	275-325	M 12

Tab. G

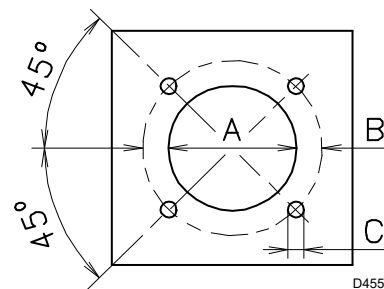

Fig. 11

5.6 Blast tube length

The length of the blast tube must be selected according to the indications provided by the manufacturer of the boiler, and in any case it must be greater than the thickness of the boiler door complete with its fettling.

The range of lengths available, L (mm), is as follows:

Blast tube 9)	RL 55/M BLU	RL 85/M BLU
	365	365

Tab. H

For boilers with front flue passes 12) or flame inversion chambers, a protection in heat-resistant material 10) must be inserted between the boiler refractory 11) and the blast tube 9).

This protection must not compromise the extraction of the blast tube.

For boilers with a water-cooled front piece, a refractory lining 10)-11)(Fig. 12) is not necessary, unless expressly requested by the boiler manufacturer.

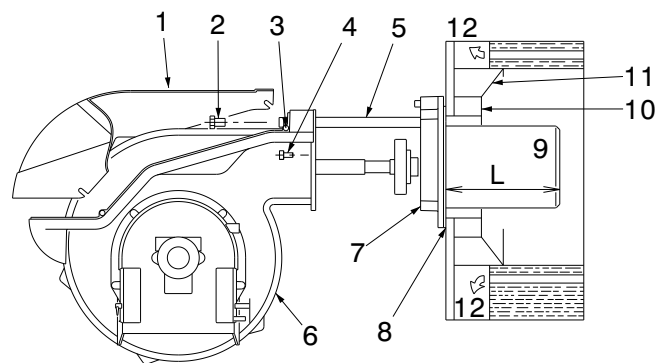

Fig. 12

5.7 Securing the burner to the boiler



Provide an adequate lifting system.



Be careful as some drops of fuel may leak out during this phase.

Remove blast tube 9)(Fig. 13) from the burner 6):

- loosen the 4 screws 3) and remove the cover 1);
- remove screws 2) from the two slide bars 5);
- remove the 2 screws 4) retaining the burner 6) to the flange 7);
- remove the blast tube 9) complete with flange 7) and slide bars 5).

Fix the flange 7)(Fig. 13) to the plate of the boiler interposing the seal 8)(Fig. 13) supplied with the unit.

Use the 4 screws, also supplied, after protecting their thread with an anti-locking product.

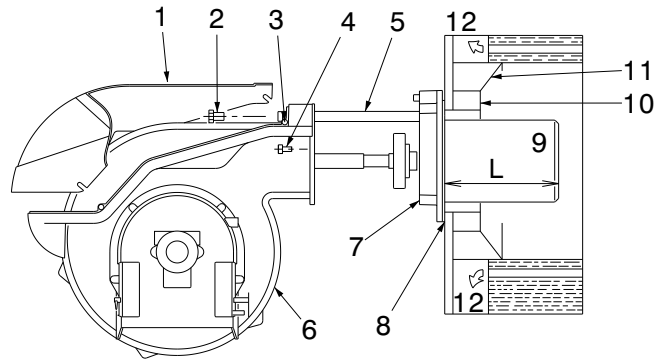

20175868

Fig. 13



ATTENTION

The seal between burner and boiler must be airtight.

5.8 Electrode positions



ATTENTION

Check that the electrodes are positioned correctly, as in Fig. 14, complying with the dimensions indicated.

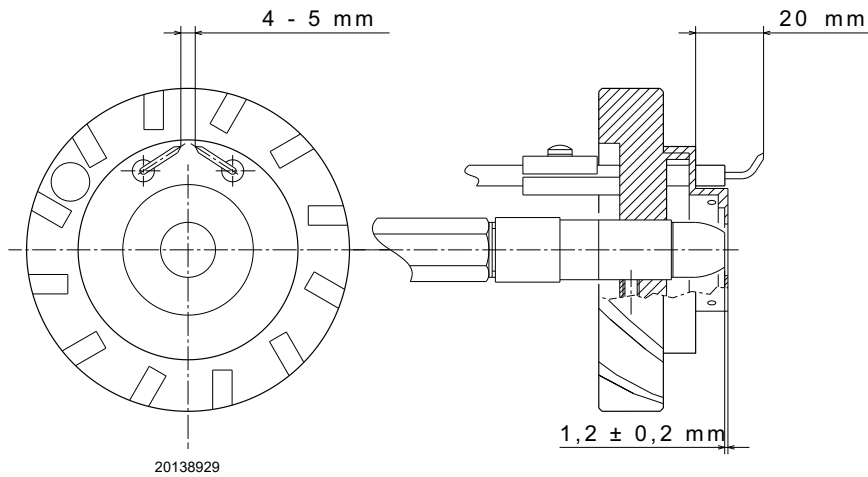

20138929

Fig. 14

5.9 Nozzle installation

The burner complies with the emission requirements of the EN 267 standard.

In order to guarantee that emissions do not vary, recommended and/or alternative nozzles specified by Riello in the Instruction and warning booklet should be used.



The use of nozzles other than those specified by Riello S.p.A. and inadequate regular maintenance may result into emission limits non-conforming to the values set forth by the regulations in force, and in extremely serious cases, into potential hazards to people and objects.

The manufacturing Company shall not be liable for any such damage arising from non-observance of the requirements contained in this manual.



It is advisable to replace the nozzle once a year during periodical maintenance.

5.9.1 Nozzle selection

See diagram (Fig. 26 on page 25).

If you want a delivery somewhere between the two values shown in the diagram (Fig. 26 on page 25), select a nozzle with a higher flow rate.

The reduction in the flow rate is obtained with the pressure variator.

NOZZLES RECOMMENDED:

- RL 55/M BLU:
Bergonzo type A3 - 60° angle
- RL 85/M BLU:
Bergonzo type A3 - 60° angle

5.10 Nozzle assembly

At this installation stage the burner is still separated from the blast tube; therefore it is possible to fit the nozzle by loosening the grub screws 1)(Fig. 15) and removing the swirl turbulator 2)(Fig. 15). Do not use any sealing products such as: gaskets, tape or sealants. Be careful to avoid damaging the nozzle sealing seat.

Finally remount the burner 3)(Fig. 16) on the slide bars 2) and slide it up to the flange 5), **keeping it slightly raised to prevent the flame stability disk from pressing against the blast tube.**

Tighten the screws 1) on the slide bars 2) and the screws 4) that fix the burner to the flange.

If it proves necessary to change a nozzle with the burner already fitted to the boiler, proceed as outlined below:

- open the burner on the slide bars 2)(Fig. 16) as shown in Fig. 12 on page 17.



- Do not use any sealing products such as: gaskets, tape or sealants.
- Be careful to avoid damaging the nozzle sealing seat.
- The nozzle must be screwed into place tightly but not to the maximum torque value provided by the wrench.

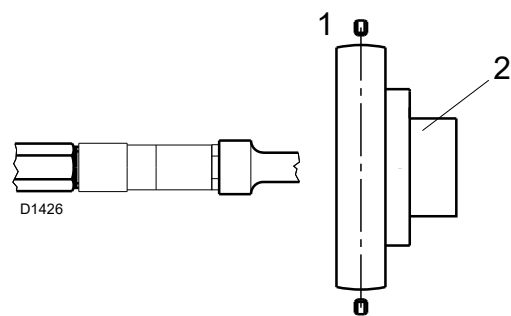

Fig. 15

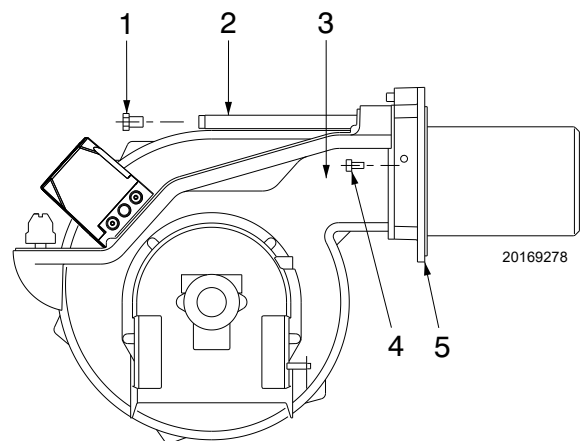

Fig. 16

5.11 Combustion head adjustment

The recommended combustion head adjustment is at notch 3, as shown in Fig. 17.

Rotate the screw 4) until notch 3 corresponds with the front flange surface 5).

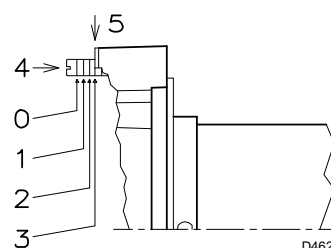

Fig. 17

5.12 Light oil supply



Explosion danger due to fuel leaks in the presence of a flammable source.

Precautions: avoid knocking, attrition, sparks and heat.

Make sure the fuel shut-off valve is closed before performing any operation on the burner.



ATTENTION

The fuel supply line must be installed by qualified personnel, in compliance with current standards and laws.

The burner is equipped with a self-priming pump which is capable of feeding itself within the limits listed in the table at the side.

Double-pipe circuit (Fig. 18)

The burner is equipped with a self-priming pump which is capable of feeding itself within the limits listed in the table at the side.

The tank is higher than the burner A

The distance P must not exceed 10 meters in order to avoid subjecting the pump seal to excessive strain; the distance V must not exceed 4 meters in order to permit pump self-priming even when the tank is almost completely empty.

The tank is lower than the burner B

The pump depression value must not exceed 0.45 bar (35 cm Hg). Because at higher levels gas is released from the fuel; the pump becomes noisy and its lifetime is shortened.

It is good practice to ensure that the return and suction lines enter the burner from the same height; the suction line is more difficult to disconnect.

Loop circuit

The loop circuit is composed of a duct starting from the tank and going back to it, in which an auxiliary pump makes the pressurised fuel flow.

A branch from the loop supplies the burner.

This circuit is extremely useful whenever the burner pump does not succeed in self-priming because the tank distance and/or height difference are higher than the values listed in Tab. I.

+ H - H (m)	L (m)		
	Ø (mm)		
	12	14	16
+ 4.0	71	138	150
+ 3.0	62	122	150
+ 2.0	53	106	150
+ 1.0	44	90	150
+ 0.5	40	82	150
0	36	74	137
- 0.5	32	66	123
- 1.0	28	58	109
- 2.0	19	42	81
- 3.0	10	26	53
- 4.0	-	10	25

Tab. I

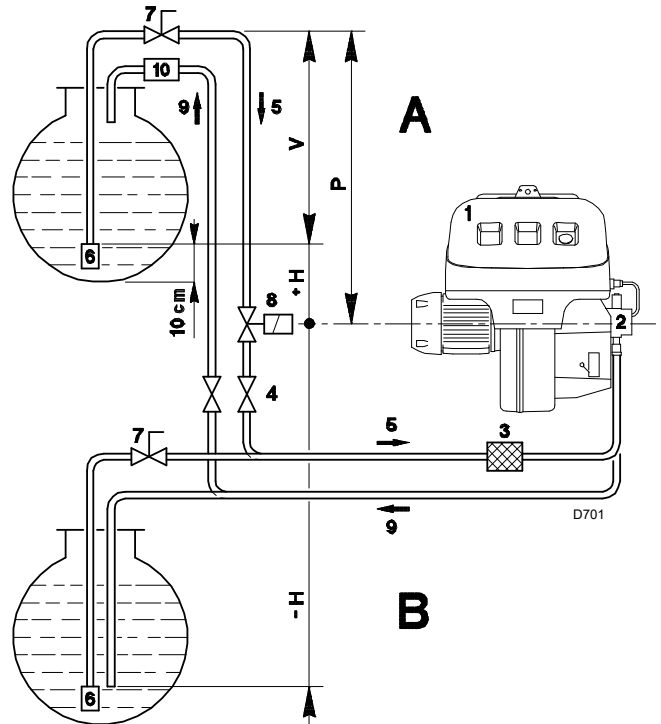

Fig. 18

Key

- H = Pump/Foot valve height difference
- L = Piping length
- Ø = Inside pipe diameter
- 1 = Burner
- 2 = Pump
- 3 = Filter
- 4 = Manual on/off valve
- 5 = Suction line
- 6 = Foot valve
- 7 = Quick closing manual valve with remote control (Italy only)
- 8 = On/off solenoid valve (Italy only)
- 9 = Return pipe
- 10 = Check valve (only Italy)

5.12.1 Hydraulic connections



- Make sure that the hoses to the pump supply and return line are installed correctly.

Double-pipe circuit

The pumps are equipped with a by-pass that connects return line with suction line.

They are installed on the burner with the by-pass closed by screw 6)(Fig. 20).

It is therefore necessary to connect both hoses to the pump.

The pump will break down immediately if it is run with the return line closed and the by-pass screw inserted.

Remove plugs from suction and return connectors of the pump.

Insert the hose connections with the supplied seals into the connections and screw them down.

Install the hoses where they cannot be stepped on or come into contact with hot surfaces of the boiler.

Finally, connect, the other end of the hoses to the suction line and return line ducts using the nipples supplied with the equipment.



- During the installation, hoses must not be stressed with twisting.

Single-pipe circuit (not recommended)

If the pump is fed with a single-pipe circuit, it is necessary to:

- remove the screw 6)(Fig. 20) (open by-pass) before making the hydraulic connections;
- insert a degasser in the circuit (refer to kit list).

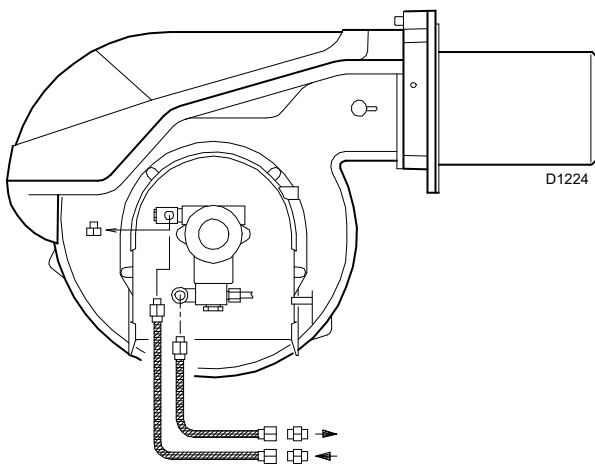

Fig. 19

5.12.2 Hydraulic circuit diagram

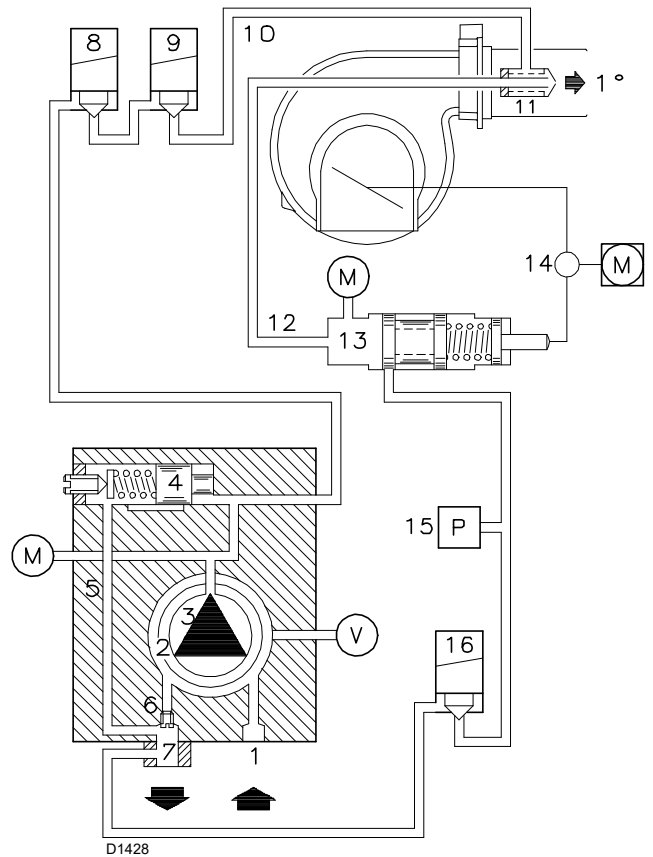

Fig. 20

- 1 Pump suction line
- 2 Filter
- 3 Pump
- 4 Pressure adjuster
- 5 Pressure test point
- 6 Bypass screw
- 7 Pump return line
- 8 Safety valve
- 9 Working valve
- 10 Delivery line
- 11 Nozzle
- 12 Return line
- 13 Pressure adjuster
- 14 Pressure adjustment eccentric
- 15 Maximum oil pressure switch
- 16 Return valve
- M Pressure gauge
- V Vacuumeter

5.13 Pump

5.13.1 Technical data

Pump		J6
Min. delivery rate at 20 bar pressure	kg/h	163
Delivery pressure range	bar	10 - 21
Max. suction depression	bar	0.45
Viscosity range	cSt	2.8 - 200
Max. light oil temperature	°C	90
Max. suction and return pressure	bar	1.5
Pressure calibration in the factory	bar	20
Filter mesh width	mm	0.170

Tab. J

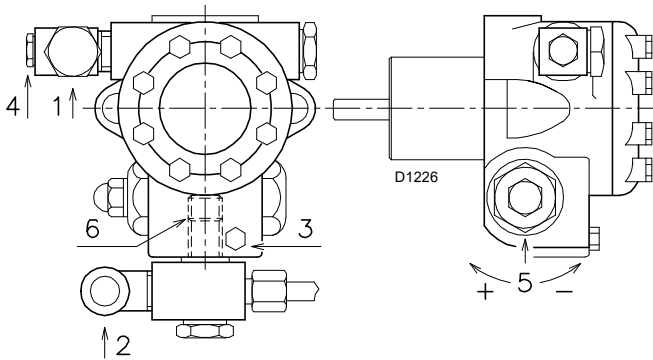

Fig. 21

- 1 Suction line G 1/2"
- 2 Return line G 1/2"
- 3 Pressure gauge connection G 1/8"
- 4 Vacuum connection G 1/8"
- 5 Pressure adjustment
- 6 By-pass screw

5.13.2 Priming pump

- Before starting the burner, make sure that the tank return line is not clogged. **Obstructions in the line could cause the sealing organ located on the pump shaft to break.**
- In order for self-priming to take place, the screw 3)(Fig. 21) of the pump must be loosened in order to bleed off the air contained in the suction line.
- Start the burner by closing the control devices and with the switch 1)(Fig. 25 on page 25) in "MAN" position. As soon as burner starts, check the fan rotation direction through the flame inspection window 25).
- The pump can be considered to be primed when the light oil starts coming out of the screw 3). Stop the burner: set switch 1)(Fig. 25 on page 25) to "OFF" and tighten the screw 3).

The time required for this operation depends upon the diameter and length of the suction tubing. If the pump fails to prime at first start-up and the burner locks out, wait approx. 15 seconds, reset the burner, and then repeat the start-up operation. And so on. After 5 or 6 starting operations allow 2 or 3 minutes for the transformer to cool.



ATTENTION

The above-mentioned operation is possible because the pump is already full of fuel when it leaves the factory. If the pump has been drained, fill it with fuel through the opening on the vacuum meter prior to starting; otherwise, the pump will seize.

Whenever the length of the suction piping exceeds 20-30 meters, the supply line must be filled using a separate pump.

5.14 Electrical connections

Notes on safety for the electrical wiring



DANGER

- The electrical wiring must be carried out with the electrical supply disconnected.
- Electrical wiring must be made in accordance with the regulations currently in force in the country of destination and by qualified personnel. Refer to the wiring diagrams.
- The manufacturer declines all responsibility for modifications or connections different from those shown in the wiring diagrams.
- Check that the electrical supply of the burner corresponds to that shown on the identification label and in this manual.
- The burners have been set for intermittent operation (FS1).
- The RFGO safety device features two built-in flame amplifiers which allow using it for applications with UV sensor only, FR sensor only or with both sensors (UV+FR).
The FR amplifier circuit is subject to constant auto-control, which allows to use it for applications requiring a burner operating cycle longer than 24 hours.
When it is used as a UV control, the system is considered as non-permanent, requiring one burner recycle every 24 hours.
Normally, burner stopping is guaranteed by the boiler's thermostat/pressure switch.
If this is not the case, a time switch must be applied to L-N in series, to stop the burner at least once every 24 hours. Refer to the wiring diagrams.
- The electrical safety of the device is obtained only when it is correctly connected to an efficient earthing system, made according to current standards.
It is necessary to check this fundamental safety requirement. In the event of doubt, have the electrical system checked by qualified personnel.
Do not use the gas tubes as an earthing system for electrical devices.
- The electrical system must be suitable for the maximum power absorption of the device, as indicated on the label and in the manual, checking in particular that the section of the cables is suitable for that level of power absorption.
- For the main power supply of the device from the electricity mains:
 - do not use adapters, multiple sockets or extensions;
 - make provisions for an omnipolar switch with a gap between the contacts of at least 3 mm (over-voltage category III), as required by current safety regulations.
- Do not touch the device with wet or damp body parts and/or in bare feet.
- Do not pull the electric cables.

Before carrying out any maintenance, cleaning or checking operations:



DANGER

Disconnect the electrical supply from the burner by means of the system main switch.



DANGER

Close the fuel shut-off valve.



DANGER

Avoid condensate, ice and water leaks from forming.

If the cover is still present, remove it and proceed with the electrical wiring according to the wiring diagrams.

Use flexible cables according to EN 60 335-1 standard.

5.14.1 Supply cables and external connections passage

All the cables to be connected to the burner terminal board 8)(Fig. 22) must be threaded through cable grommets.

The use of the cable grommets and the pre-blanked holes can be done in different manners; for example:

- 1 Pg 13.5 three-phase power supply
- 2 Pg 11 single-phase power supply
- 3 Pg 13.5 TL remote control
- 4 Pg 9 TR remote control or probe (RWF)
- 5 Pg 9 Preparing for pipe union
- 6 Pg 11 Preparing for pipe union
- 7 Pg 13.5 Preparing for pipe union

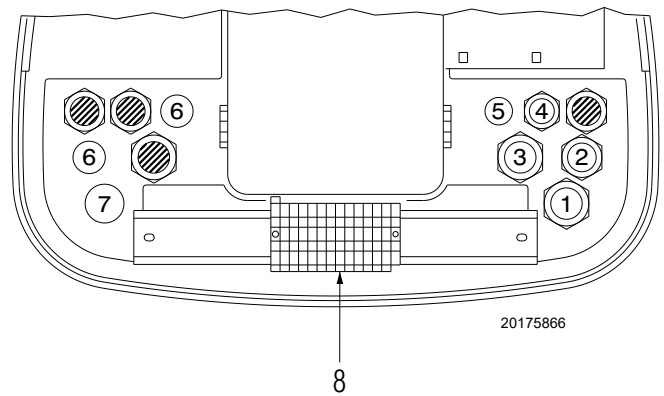

Fig. 22



After carrying out maintenance, cleaning or checking operations, reassemble the cover and all the safety and protection devices of the burner.

5.15 Calibration of the thermal relay

The thermal relay serves to avoid damage to the motor due to an excessive absorption increase or if a phase is missing.

For calibration 2), refer to the table indicated in the electrical layout (electrical wiring by the installer).

To reset, in case of an intervention of the thermal relay, press button "RESET" 1).

The button "STOP" 3) opens the NC contact (95-96) and stops the motor.

Insert a screwdriver in the window "TEST/TRIP" 4) and move it in the arrow direction (to the right) to carry out the thermal relay test.

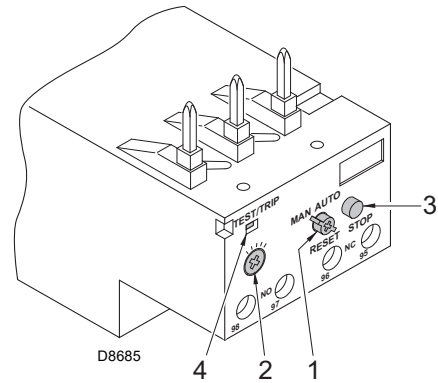

Fig. 23



The automatic reset can be dangerous. This operation is not foreseen in the burner operation.

ATTENTION

5.16 Motor rotation

As soon as the burner starts, place yourself in front of the cooling fan of the fan motor and check that it turns anticlockwise (Fig. 24).

If this is not the case:

- put the switch of the burner to "0" (off) and wait until the control box carries out the switching off phase.



Disconnect the electrical supply from the burner by means of the system main switch.

DANGER

- Invert the phases on the three-phase motor power supply.

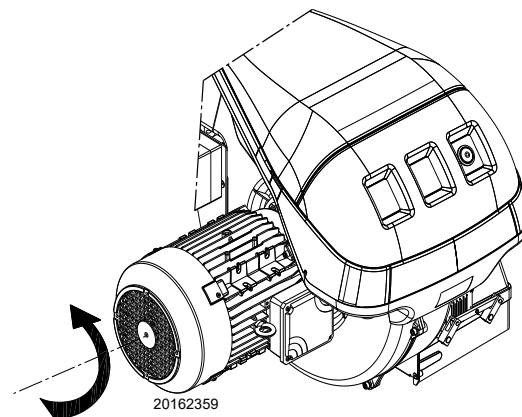

Fig. 24

6 Start-up, calibration and operation of the burner

6.1 Notes on safety for the first start-up



The first start-up of the burner must be carried out by qualified personnel, as indicated in this manual and in compliance with the standards and regulations of the laws in force.



Check the correct working of the adjustment, command and safety devices.

6.2 Burner ignition

Turn off the remote controls and set the switch 1)(Fig. 25) to "MAN".

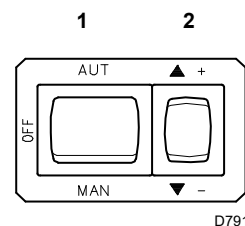

Fig. 25

6.3 Operation

The optimum adjustment of the burner requires an analysis of flue gases at the boiler outlet.

The adjustments that have already been performed and generally do not need variations are:

- Combustion head
- Servomotor, cams I - II - III - IV - V

Whereas the following must be adjusted one after the other:

- 1 MAX burner output;
- 2 MIN burner output;
- 3 Intermediate outputs between the two.

6.3.1 MAX output

MAX output must be selected within the firing rate range shown on page 10.

In the above instructions we left the burner running at the MIN output.

Now press the button 2)(Fig. 25) "+" and keep it pressed until the servomotor has reached 130°.

Nozzle output adjustment

The nozzle output varies depending on the light oil pressure on the nozzle return line.

The diagram (Fig. 26) indicates this relation for Bergonzo type A2 nozzles with a 20 bar pump delivery pressure.

Diagram:

Horizontal axis : bar, nozzle return line pressure

Vertical axis : kg/h, nozzle output

NOTE:

with a 20 bar pump delivery pressure we strongly advise against a nozzle return line pressure greater than 17 bar. The pressure difference between pump delivery and nozzle return line must be at least 3 bars. With smaller pressure differences, the nozzle return line pressure may be unstable.

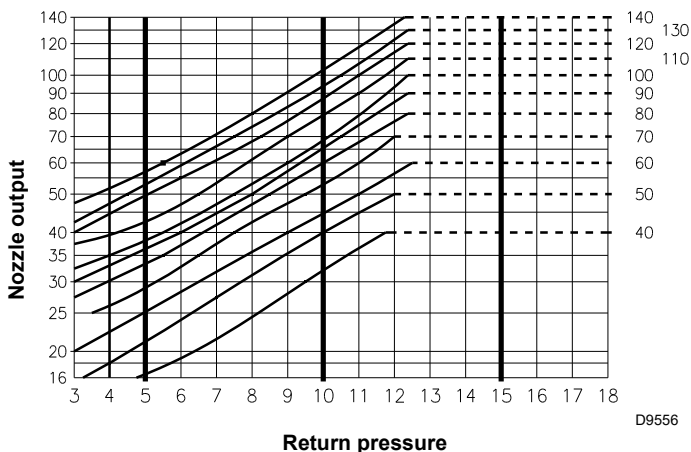

Fig. 26

Pressure variator

The value of the pressure on the return line of the nozzle is shown on the pressure gauge 1)(Fig. 27).

The pressure and the flow output of the nozzle are at their maximum when the servomotor is at the 130° position.

The return line pressure corrections are possible by changing the eccentric 6)(Fig. 27) and the nut with the lock nut 4)(Fig. 27).

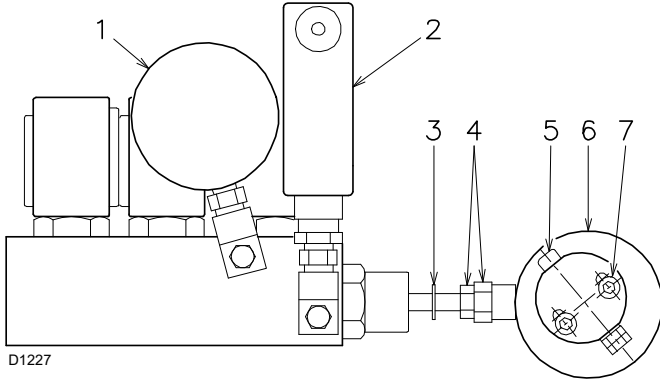

Fig. 27

- 1 Nozzle return pressure gauge
- 2 Oil pressure switch
- 3 Piston stop ring
- 4 Piston calibration nut and lock nut
- 5 Eccentric adjustment screw
- 6 Variable eccentric
- 7 Eccentric locking screws

NOTE:

- **For a correct calibration, the eccentric 6) must operate on the entire range of travel of the servomotor (30° ÷ 130°): a pressure variation must correspond to each servomotor variation.**
- **Never drive the variator piston fully home: the stop ring 3)(Fig. 27) determines the maximum stroke.**
- **At the end of the adjustment, manually check, after unlocking the servomotor (refer to page 27), that between 0° and 130° there is no sticking and that the maximum and minimum pressures correspond to the one selected according the diagram (Fig. 26 page 25).**
- **If you want to check the output delivery of the nozzle, open the burner, connect a pipe to the nozzle, simulate the ignition and proceed with the weighing of the fuel at the maximum and minimum pressures.**

If at the maximum delivery of the nozzle (maximum pressure on the return line) pressure oscillations can be seen on the pressure gauge 1), slightly reduce the pressure until they disappear.

To calibrate the eccentric, loosen screws 7), and turn screw 5) until the desired eccentricity is obtained. turning the screw 5) to the right the eccentricity increases, thus widening the difference between maximum and minimum nozzle flow output; whereas turning the screw 5) to the left the eccentricity decreases, thus reducing the difference between maximum and minimum nozzle flow output.

Air adjustment

Progressively adjust the end profile of cam 2)(Fig. 28) by turning the screws 5).

- Turn the screws clockwise to increase air delivery.
- Turn the screws anticlockwise to reduce air delivery.

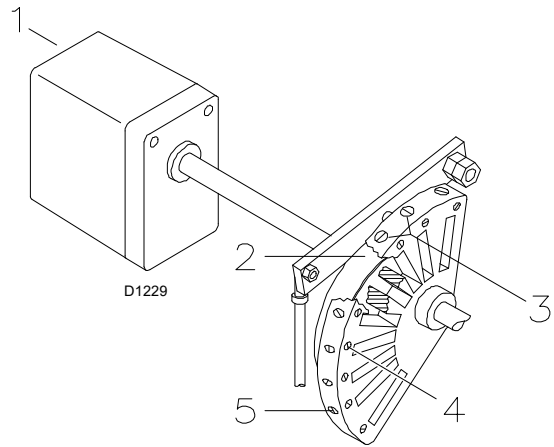

Fig. 28

- 1 Servomotor
- 2 Variable profile cam
- 3 Screws for adjusting the cam's adjustable profile
- 4 Screws for fixing the adjustment
- 5 Screws for adjusting the cam's adjustable profile

6.3.2 MIN output

MIN output must be selected within the firing rate range indicated on page 10.

Press button 2)(Fig. 25 page 25) "Output decrease" and keep it pressed until the servomotor reaches 30° (factory adjustment).

Nozzle output adjustment

The nozzle flow output is given in the diagram (Fig. 26 on page 25) in correspondence with the nozzle return line pressure, measured with the pressure gauge 1)(Fig. 27).

The pressure and the flow output of the nozzle are at their minimum level when the servomotor is at the 30° position.

For calibrating the return line pressure, refer to page 25.

Air flow adjustment

Progressively adjust the initial profile of cam 2)(Fig. 28) by turning the screws 3).

If possible, do not turn the first screw, since this is used to set the air damper to its fully closed position.

6.3.3 Intermediate outputs light oil/air delivery adjustment

Lightly press the "increase output" button 2)(Fig. 25 on page 25) so the servomotor rotates by about 15°.

Adjust the screws until optimal combustion is obtained. Proceed in the same way with the other screws.

Take care that the cam profile variation is progressive.

Switch the burner off with switch 1)(Fig. 28), OFF position. Release cam 2)(Fig. 28) from the servomotor by pressing and shifting button 3)(Fig. 29 on page 27) to the right, and check several times that by rotating cam 2) forwards and backwards by hand, the movement is soft and smooth, without jamming.

Join the cam 2) to the servomotor again by shifting the button 2)(Fig. 29 on page 27) to the left.

As far as is possible, try not to move those screws at the ends of the cam that were previously adjusted for the opening of the air damper to MAX and MIN output.

Once MAX - MIN - INTERMEDIATE outputs have been adjusted, recheck the ignition: its noise must be equal to the one of the following operation.

If you notice any sign of pulsations, reduce the ignition output.

Once optimum adjustment has been reached, fix it with the screws 4)(Fig. 28 on page 26).

NOTE:

The servomotor only follows the adjustment of cam III when the angle of the cam is reduced.

If it is necessary to increase the angle of the cam, you must first increase the angle of the servomotor by means of the “output increase” key, then increase the angle of cam III, and finally bring the servomotor to the position of MIN output, with the “output reduction” key.

For any necessary adjustment of cam III, especially for small movements, use the specific key 10)(Fig. 29) held in place beneath the servomotor with the aid of a magnet.

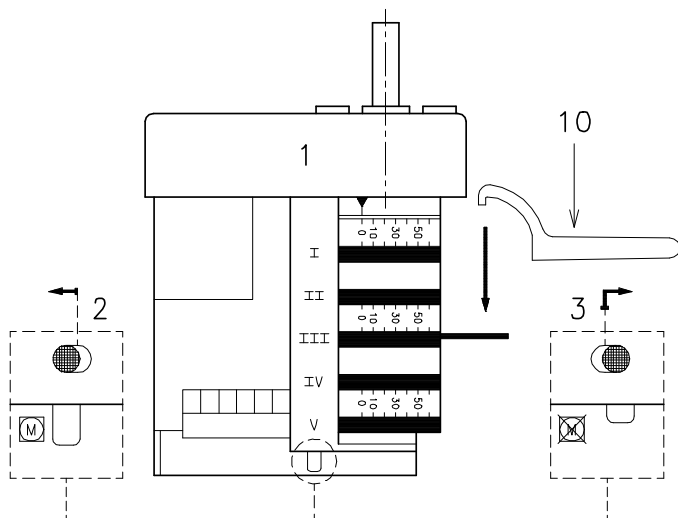

Fig. 29

6.3.4 Servomotor

The servomotor provides simultaneous adjustment of the air damper, by means of the variable profile cam and the pressure variator. The servomotor's rotation angle is 130° in 42 s.

Do not alter the factory setting for the 5 cams; just check that they are as specified below:

- Cam I:** 130° Limits rotation toward maximum position.
- Cam II:** 0° Limits rotation toward minimum position. With burner off, the air damper must be closed: 0°.
- Cam III:** 15° Adjusts the ignition position and the MIN output.
- Cam IV:** 30° Regulates the MIN modulating output.
- Cams V:** 35° It is used for reaching MIN output at start-up. Its calibration must be greater than the one pertaining to cam IV.

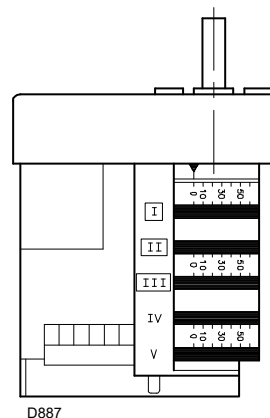

Fig. 30

6.4 Pressure switch adjustment

6.4.1 Oil pressure switch

The pressure switch 5)(Fig. 5 on page 12) is adjusted in the factory at 3 bar. If the light oil pressure reaches this value in the return duct, the pressure switch stops the burner.

The burner restarts automatically if the pressure goes back to less than 3 bar after stopping.

If the burner is fed by a loop circuit with a pressure of Px, the pressure switch must be adjusted at Px + 3 bar.

To adjust the pressure switches, use a tool to operate the adjustment screw, see Fig. 31.

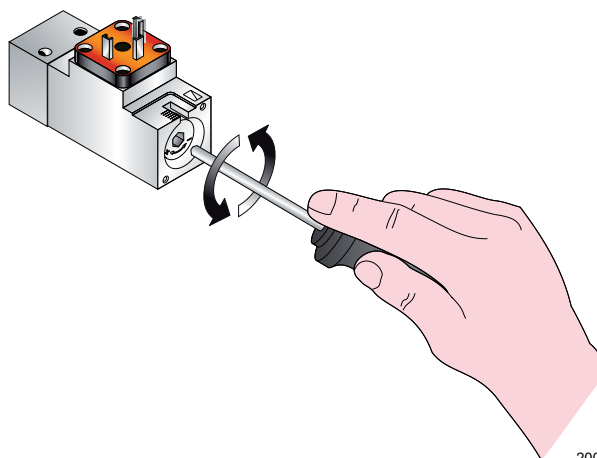

20079898

Fig. 31

6.5 Operation sequence of the burner

6.5.1 Burner start-up

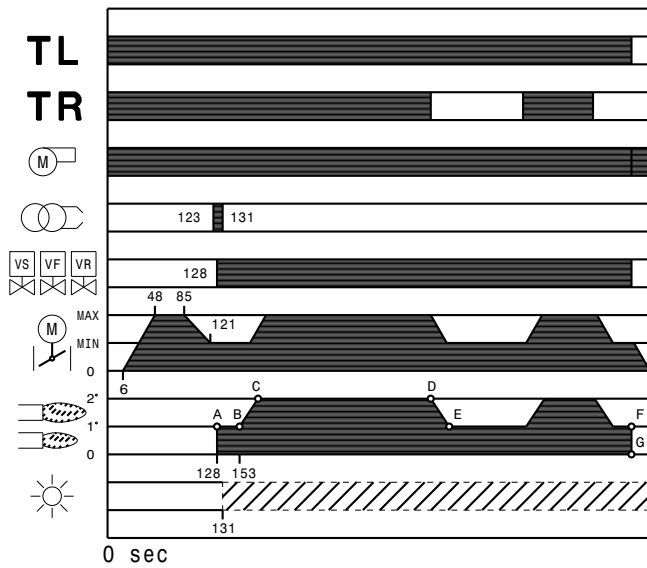

Fig. 32

- 0 s :** TL remote control closing, motor starting.
The pump 3)(Fig. 20 on page 21) sucks the fuel from the tank through the piping 1) and the filter 2) and pumps it under pressure to delivery. The piston 4) rises and the fuel returns to the tank through the piping 5) - 7).
The screw 6) closes the by-pass towards the suction line and the solenoid valves 8)-9)-16)(Fig. 20 on page 21), de-energised, closing the path towards the nozzle.
- 6 s :** Servomotor start-up: turn to the right by 130°, i.e. until the contact intervenes on cam I (Fig. 29 on page 27). The air damper is positioned to MAX output.
- 48 s :** Pre-purging stage with MAX output air flow.
- 85 s :** The servomotor rotates to the left until the contact on cam 3) activates (Fig. 29 on page 27).
- 121 s :** The air damper and the pressure variator go to the ignition output position.
- 123 s :** Ignition electrode strikes a spark.
- 128 s :** Solenoid valves 8)-9)-16)(Fig. 20 on page 21) open; the fuel goes through the duct 10), passing through the filter 11) and enters the nozzle. A part of the fuel is sprayed out of the nozzle and when it reaches the spark ignites: low output flame, point A; the rest of the fuel goes through the duct 12 at the pressure preset by the variator 13, then it goes back to the tank through the duct 7).
- 131 s :** The spark goes out.
- 153 s :** The start-up cycle ends.

6.6 Final checks

- **Block the flame sensor and turn off the remote controls:** the burner must start and then stop in lockout after approximately 5 s after start-up.
- **Free the flame sensor and turn off the remote controls:** the burner must stop in lockout.
- **Block the flame sensor when the burner is operating:** the flame must turn off and the burner stop in lockout within 1 s.
- **Turn on the remote control TL followed by TS while the burner is operating:** the burner must stop.

6.5.2 Steady state operation

Burner without output regulator RWF

Once the start-up cycle is completed, the servomotor command moves on to the TR remote control that controls the pressure or the temperature in the boiler, point B.

- If the temperature or pressure is low (so the TR remote control is closed), the burner progressively increases the output up to the MAX value (section B-C).
- If subsequently the temperature or pressure increases until TR opens, the burner progressively decreases its output to the MIN value (section D-E). And so on.
- The burner locks out when the heat request is less than the heat supplied by the burner at MIN output, (section F-G).

The TL remote control opens, the servomotor returns to angle 0° limited by the contact of cam II (Fig. 29 on page 27). The air damper closes completely to reduce heat losses to a minimum.

With each change of output, the servomotor automatically modifies the light oil output (pressure variator) and the air flow rate (fan damper).

Burner with output regulator RWF

See the manual supplied with the regulator.

6.5.3 Ignition failure

If the burner does not ignite, it locks out within 2.5 seconds after the light oil valve opens, and the post-purging phase starts lasting 15 seconds.

6.5.4 Burner flame goes out during operation

If the flame should accidentally go out during operation, the burner will lock out within 1s.



Make sure that the mechanical locking systems on the adjustment devices are fully tightened.

7 Maintenance

7.1 Notes on safety for the maintenance

The periodic maintenance is essential for the good operation, safety, yield and duration of the burner.

It allows you to reduce consumption and polluting emissions and to keep the product in a reliable state over time.



The maintenance interventions and the calibration of the burner must only be carried out by qualified, authorised personnel, in accordance with the contents of this manual and in compliance with the standards and regulations of current laws.

Before carrying out any maintenance, cleaning or checking operations:



Disconnect the electrical supply from the burner by means of the system main switch.



Close the fuel shut-off valve.



Wait for the components in contact with heat sources to cool down completely.

7.2 Maintenance programme

7.2.1 Maintenance frequency



The gas combustion system should be checked at least once a year by a representative of the manufacturer or another specialised technician.

7.2.2 Checking and cleaning



The operator must use the required equipment during maintenance.

Combustion

Carry out an analysis of the combustion flue gases. Significant differences with respect to the previous measurements indicate the points where more care should be exercised during maintenance.

If the combustion values measured before starting maintenance do not comply with applicable Standards or do not indicate efficient combustion, consult the table below or contact our Technical Support Service to implement the necessary adjustments.

EN 267	Air excess		CO
	Max. output $\lambda \leq 1.2$	Min. output $\lambda \leq 1.3$	
Theoretical max CO ₂ 0 % O ₂	CO ₂ % Calibration		mg/kWh
	$\lambda = 1.2$	$\lambda = 1.3$	
15.2	12.6	11.5	≤ 100

Tab. K

Combustion head

Check to make sure that all the parts of the combustion head are in good condition, positioned correctly, free of all impurities, and that no deformation has been caused by operation at high temperatures.

Pump

The delivery pressure must be stable at 20 bar.

The depression must be less than 0.45 bar.

Unusual noise must not be evident during pump operation.

If the pressure is unstable, or the pump runs noisily, the flexible hose must be detached from the line filter and the fuel must be sucked from a tank located near the burner. This measure permits the cause of the anomaly to be traced to either the suction piping or the pump.

If the pump is found to be responsible, check to make sure that the filter is not dirty. The vacuumeter is installed upstream from the filter and consequently will not indicate whether the filter is clogged or not.

Contrarily, if the problem lies in the suction line, check to make sure that the filter is clean and that air is not entering the piping.

Servomotor

Release cam 2)(Fig. 28 page 26) from the servomotor, by pressing and shifting button 3)(Fig. 29 on page 27) to the right. Manually rotate it backwards and forwards to make sure it moves smoothly.

Now engage the cam again by shifting the button 2)(Fig. 29 on page 27) to the left.

Nozzle

It is advisable to replace nozzles once a year during periodical maintenance.

Do not clean the nozzle openings.

Flexible hoses

Check to make sure that the hoses are still in good condition.

Fuel tank

Approximately every 5 years, or whenever necessary, suck any water or other impurities present on the bottom of the tank using a separate pump.

Filters

Check the following filter boxes:

- on line 1)
- in the pump 2)
- at the nozzle 3), and clean or replace as required.

If rust or other impurities are observed inside the pump, use a separate pump to lift any water and other impurities that may have deposited on the bottom of the tank (Fig. 33).

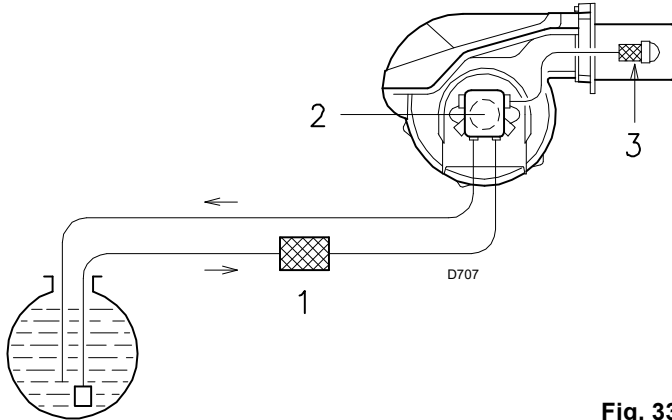

Fig. 33

Flame inspection window

Clean the viewing port (Fig. 34).

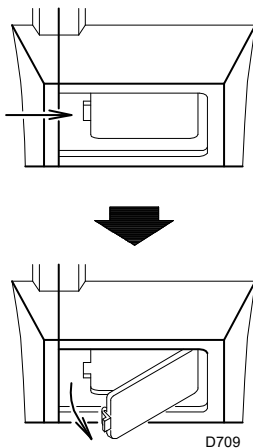

Fig. 34

Burner

Make sure that the screws are well secured.

Flame presence check

Check the level of the flame detection signal with the “Check mode” function from the flame control: LEDs from 2 to 6 indicate the flame signal level, respectively. “LED indicator and special function” on page 32.

Check Mode

With burner flame on:

- hold the reset button on the flame control pressed for at least 3 sec.;
- the button colour will change from green to yellow;
- each operating status signalling LED will be compared to 20% of the maximum brightness;
- press the reset button again (<0.5sec) to reset the standard operation of the signalling LEDs.

Possible pump and/or coupling replacement

Carry out the fitting following the instructions in the Fig. 35.

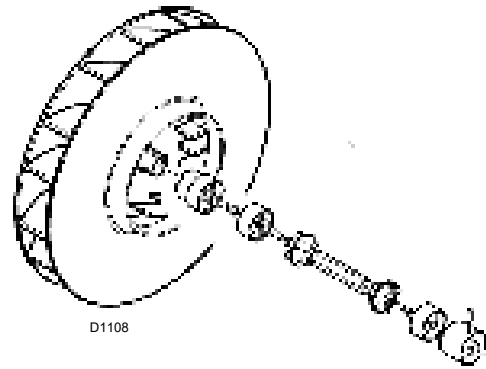

Fig. 35

7.2.3 Safety components

The safety components should be replaced at the end of their life cycle indicated in the Tab. L.

The specified life cycles do not refer to the warranty terms indicated in the delivery or payment conditions.

Safety component	Life cycle
Flame control	10 years or 250,000 operation cycles
Flame sensor	10 years or 250,000 operation cycles
Gas valves (solenoid)	10 years or 250,000 operation cycles
Pressure switches	10 years or 250,000 operation cycles
Pressure adjuster	15 years
Servomotor (electronic cam)	10 years or 250,000 operation cycles
Oil valve (solenoid)	10 years or 250,000 operation cycles
Oil regulator	10 years or 250,000 operation cycles
Pipes/ oil fittings (metallic)	10 years
Flexible hoses (if present)	5 years or 30,000 pressurised cycles
Fan impeller	10 years or 500,000 start-ups

Tab. L

7.3 Opening the burner



DANGER

Disconnect the electrical supply from the burner by means of the system main switch.



DANGER

Close the fuel shut-off valve.



Wait for the components in contact with heat sources to cool down completely.

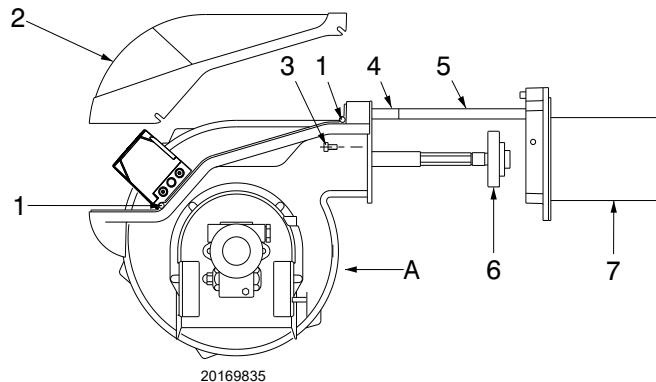

20169835

Fig. 36

To open the burner, proceed as follows:

- loosen the screws 1)(Fig. 36) and remove the hood 2);
- loosen the screws 3);
- assemble the two extensions 4) supplied on the slide bars 5);
- pull part A backward keeping it slightly raised to avoid damaging the disk 6) on blast tube 7) and disconnecting the start-up electrode cables.

7.4 Closing the burner





Refit following the steps described but in reverse order; refit all burner components as they were originally assembled.

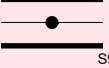
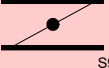

After carrying out maintenance, cleaning or checking operations, reassemble the cover and all the safety and protection devices of the burner.

8 LED indicator and special function

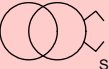
8.1 Description of LED lamps

	Fan	It turns on when the fan motor is powered (T6) and blinks when RUN/CHECK switch is set to "CHECK" during damper movement phases, PTFI AND MTFI.
	Damper open	It blinks when the air damper is moving towards the maximum opening position until the position-reached feedback sent by the servomotor is received, then it stays steadily on for the time set by the flame control.
	Damper closed	If blinks when the air damper is moving towards the minimum opening position until the position-reached feedback sent by the servomotor is received, then it stays steadily on until the end of the pre-purging time.
	Auto	It indicates that the burner is ready for the output modulation.
	Ignition	It blinks during the ignition phase (1st safety time) and stays steadily on during the MTFI.
	Flame	It blinks during the first safety time and stays steadily on if the flame detection has been correctly performed.
	Alarm	It turns on in red when a lock-out condition occurs. Together with the other indicators, it indicates the type of fault during the lock-out phase. Together with the other LEDs, it indicates the operating status during the normal cycle.

Tab. M

8.2 Check mode function

By means of the reset button on-board the flame control, it is possible to use a control function during start-up phases. (pre-purging, ignition, 1st safety time and 2nd safety time).

This function, indicated as CHECK MODE, is designed to facilitate checking the phases of the burner and of the safety devices monitored by the flame control.

This function is particularly useful during the burner first commissioning or during maintenance.

To enable the check mode function:

- keep the reset button pressed, see chapter 8 for more details, for at least 3 seconds, the status LED changes from green to yellow to signal that the control device is in check mode.
- the control device locks out during pre-purging, after a timeout of max 30 minutes the flame control will automatically exit the check mode function.





- check mode has a 2 minute timeout during the 2nd safety time. When it ends, the flame control goes back to the normal operating status.
- check mode has a 2 minute timeout during the MTFI status. When it ends, the flame control goes back to the normal operating status.
- During the check mode 1st or 2nd safety time, the flame signal level can be indicated by the 5 central LEDs on the flame control central panel, which turn on proportionally. Each lit LED (starting from the flame LED) represents 20% of the signal power.
To exit the check mode function, press the reset button; the flame control will go back to the normal operating mode.

8.3 Flame control lock-out or emergency stop condition

The RFGO control device can be locked out (emergency stop) at any time during the operating cycle and unlocked when already locked (lock-out) by simply pressing the key on the front panel or by means of the terminal T21 on the support base.

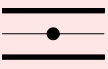
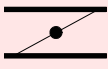
8.4 LED lamps: burner operating status

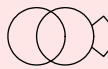
OPERATING STATUSES INDICATED BY LEDES DURING NORMAL OPERATION AND CHECK MODE

Operation LED ● = ON	Fan	Damper open	Damper closed	Modulation	Ignition	Flame	Status
Icon	 S9740	 S9741	 S9742	 S9743	 S9744	 S9745	 S9746
Power OFF/ON							OFF
Not ready/ Diagnostics							Green
Standby			●				Green
Servomotor movement (Note 3)	●	OFF Flashing ●	● Flashing OFF				Green
Waiting for closing	Green blinking						Green
OPEN (before ignition)	●	●					Green
Minimum (before ignition)	●		●				Green
Ignition	●		●		●		Green
PTFI	●		●		●	Green blinking	Green
MTFI	●		●			●	Green
Active modulation	●			●		●	Green
Minimum output position	●		●			●	Green
With flame present	●	●				●	Green
Economy mode	●		●				Green
Check during maximum opening phase	Flashing	●					Yellow
Check during minimum closing phase	Flashing		●				Yellow
Check during ignition phase with pilot PTFI	Flashing	● Note 1	● Note 1	● Note 1	● Note 1	● Note 1	Yellow
Check during ignition phase with main fuel valve MTFI	Flashing	● Note 1	● Note 1	● Note 1	● Note 1	● Note 1	Yellow
Fault/lock-out	● Note 2	● Note 2	● Note 2	● Note 2	● Note 2	● Note 2	Red
End of the cycle	●		●	●			Green

Tab. N

1. LEDs form a progress bar which indicates the Flame Signal Power in order to orientate the sensors during commissioning (LEDs "Grow" upwards, moving away from the Status at 20% intervals of flame power.)
2. LEDs indicate the error or lock-out code for troubleshooting.
3. LEDs change from ON to BLINKING to OFF showing the servomotor movement control until the position-reached feedback is received See paragraph "**Problems - Causes - Remedies signalled by LED indicators**" on page 34".

9 Problems - Causes - Remedies signalled by LED indicators

When an emergency stop occurs, the control device LEDs indicate the cause of the stop.
 The terminal T3 is not powered.
 The device operating status is internally memorised in case of any lack of power supply.

The device lock-out condition can be caused by pressing (<1sec.) the reset button on the flame control front side or through the remote reset - terminal T21 on the base.
 Since the reset button is very sensitive, do not press it strongly during the reset operation.

Unlocking the control device

The RFGO control device can be reset in two ways: reset button and remote reset terminal.

The remote reset must be a normally open connected button between T21 and flame control power supply voltage (see illustrative diagrams):

- the reset is performed when a faulty condition is detected by the flame control.
- Press the reset button to reset the system after a lock-out.
- Pressing the reset button during operation will cause an emergency stop.
- The reset or emergency stop condition can be obtained also by using the remote reset with the same modalities.
- The number of reset attempts is limited to a maximum of 5 within 15 minutes.

Error / RFGO LED lock-out Codes

During an alarm condition, the status LED becomes steady red. The remaining LEDs turn on according to a coded sequence which identifies the lock-out cause.

The following table shows the different LED Lock-out codes.



The device described in this manual can cause material problems, severe injuries or death.

It is the owner or user's responsibility to make sure that the equipment described is installed, used and commissioned in compliance with the requirements provided both by national and local law. The lock-out condition indicates the presence of a fault which occurred during the operating cycle or during stand-by mode.

Before performing an unlock attempt, it is necessary to restore the original optimal operating conditions.



Thermal unit's operation, maintenance and troubleshooting interventions must be carried out by trained personnel.

The persons who solve lock-out problems or reset the control device must observe the error codes to solve the problems described in this product technical data sheet.

It is not admitted to tamper with or act on the system or control in a way that could compromise the product safety or warranty.

Any tests on safety devices or on loads, such as fan motor, valves, igniter, flame sensors, must be performed with the shut-off valves closed and by qualified personnel.

Do not by-pass nor exclude the safety devices connected to the flame control.

Failure to observe these guidelines will exclude any liability.





The regulation prohibits the system from allowing more than 5 remote reset attempts within a 15 minute time window.

If more than 5 attempts are performed without solving the lock-out, the system will prevent the user to perform further remote resets and force him/her to wait for the 15 minutes to elapse.

The remote reset operation will be restored at the end of the waiting time.

It is recommended that qualified personnel evaluate the lock-out condition and implement the solution which is suitable for the fault to be solved.

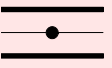
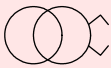
Error / RFGO LED lock-out codes

No.	Faults	LED 1	LED 2	LED 3	LED 4	LED 5	LED 6	LED 7
	Operation LED ● = ON	Fan	Open damper	Closed damper	Auto	Ignition	Flame	Status
	Icon	 S9740	 S9741	 S9742	 S9743	 S9744	 S9745	 S9746
1	Post-diagnostics fault	●						Red
2	Local reset		●					Red
3	Combustion air fan fault	●	●					Red
4	Supervisor processor diagnostics fault			●				Red
5	FR- NO Flame at the end of the 2 nd safety time (MTFI)	●		●				Red
6	FR: internal circuit fault		●	●				Red
7	Internal communication fault	●	●	●				Red
8	Remote reset				●			Red
9	FR: internal fault	●			●			Red
10	Main processor fault		●		●			Red
11	Data memory test fault	●	●		●			Red
12	Data memory test fault			●	●			Red
13	Mains voltage or frequent fault	●		●	●			Red
14	Internal processor fault		●	●	●			Red
15	Internal processor fault	●	●	●	●			Red
16	No flame: 1 st safety time (PTFI)	●				●		Red
17	Wiring fault		●			●		Red
18	Safety relay fault	●	●			●		Red
19	Combustion airflow switch fault in the rest position			●		●		Red
20	UV: no flame at the end of the 2 nd safety time (MTFI)	●		●		●		Red
21	Safety relay fault		●	●		●		Red
22	Supervisor processor fault	●	●	●		●		Red
23	Supervisor memory test fault				●	●		Red
24	Flame loss during the operation (AUTO)	●			●	●		Red
25	Supervisor processor data memory fault		●		●	●		Red
26	Supervisor processor internal fault	●	●		●	●		Red
27	Not used							
28	Not used							
29	Operating temperature out of range		●	●	●	●		Red
30	Code memory fault	●	●	●	●	●		Red
31	FR: external short circuit						●	Red
32	Check mode timeout (manual)	●					●	Red
33	False flame in stand-by mode		●				●	Red
34	Not used							
35	Internal processor timeout			●			●	Red
36	Internal processor timeout	●		●			●	Red
37	Combustion air check timeout		●	●			●	Red
38	Internal processor timeout	●	●	●			●	Red
39	Internal processor timeout				●		●	Red
40	Internal hardware fault	●			●		●	Red
41	Internal hardware fault		●		●		●	Red
42	Main processor fault	●	●		●		●	Red
43	Supervisor processor fault			●	●		●	Red
44	Supervisor processor timeout	●		●	●		●	Red
45	Off-specification mains voltage		●	●	●		●	Red

No.	Faults	LED 1	LED 2	LED 3	LED 4	LED 5	LED 6	LED 7
46	Off-specification mains voltage	•	•	•	•		•	Red
47	UV: Internal fault					•	•	Red
48	Supervisor processor fault	•				•	•	Red
49	Main processor fault		•			•	•	Red
50	Ignition feedback fault	•	•			•	•	Red
51	Pilot feedback fault			•		•	•	Red
52	Piloted valve feedback fault	•		•		•	•	Red
53	Actuator feedback waiting time expired		•	•		•	•	Red
54	Direct ignition valve feedback fault	•	•	•		•	•	Red
55	Internal processor fault				•	•	•	Red
56	UV: false flame during operation			•	•	•	•	Red
57	FR: false flame during operation	•		•	•	•	•	Red
58	T8 inlet fault		•	•	•	•	•	Red
59	Internal hardware fault	•			•	•	•	Red
60	Local reset fault	•	•	•	•	•	•	Red
61	Open POC fault		•		•	•	•	Red
62	UV: strong UV flame fault	•	•		•	•	•	Red
63	Internal hardware fault					•		Red

Tab. O
Fault explanation

No.	Faults	Cause	Solution
1	Post-diagnostics fault	Initial power diagnostics fault Make sure that the status of inlets and outlets is correct upon ignition	Check T12, T13 and T14
2	Local reset	The user started the manual reset or the reset switch is faulty	Check T21 inlet or reset for normal operation
3	Combustion air fan fault	No Air Check signal (T14) during the bleed cycle or Air Check signal loss during the burner operation	Check the fan or the air pressure switch
4	Supervisor processor diagnostics fault	The system detected the presence of voltage on T16, T17, T18 or T19 at the wrong moment or there is no voltage when necessary	Check the wiring and make sure that the system is operating on a single-phase line (50/60Hz)
5	FR- No flame at the end of the 2 nd safety time (MTFI)	No flame at the end of the second safety time	Inspect the system, check the gas pressure, inspect the flame detection electrode, check the wiring, etc.
6	FR: internal circuit fault	Internal fault	Replace the control device
7	Internal communication fault	Internal fault	Replace the control device
8	Remote reset	The user pressed the remote reset button or the reset switch is discontinuous/dynamic	Check the remote switch
9	FR: internal fault	Internal fault	Replace the control device
10	Main processor fault	Internal fault	Replace the control device
11	Data memory test fault	Internal fault	Replace the control device
12	Data memory test fault	Internal fault	Replace the control device
13	Mains voltage or frequent fault	Off-specification power supply voltage and/or frequency	Check the input power supply
14	Internal processor fault	Internal fault	Replace the control device
15	Internal processor fault	Internal fault	Replace the control device
16	No flame: 1 st safety time (PTFI)	No flame at the end of the first safety time	Inspect the system, check the gas pressure, check the flame sensor, check the wiring, etc.
17	Wiring fault	The system detected the presence of voltage on critical terminals (T16, T17, T18 or T19) at the wrong moment or there is no voltage when necessary	Inspect the wiring and make sure that the system is operating on a single-phase line (50/60Hz)
18	Safety relay fault	Internal fault	Replace the control device
19	Combustion airflow switch fault in the rest position	Open the circuit upon T13 start-up	Check the wiring for the air pressure switch

No.	Faults	Cause	Solution
20	UV: no flame at the end of the 2 nd safety time (MTFI)	No flame at the end of the 2 nd safety time	Inspect the system, check the gas pressure, check the flame sensor, check the wiring, etc.
21	Safety relay fault	Internal fault	Replace the control device
22	Supervisor processor fault	Internal fault	Replace the control device
23	Supervisor memory test fault	Internal fault	Replace the control device
24	Flame loss during the operation (AUTO)	Loss of flame	Check the flame sensor or the fuel flow line
25	Supervisor processor data memory fault	Internal fault	Replace the control device
26	Supervisor processor internal fault	Internal fault	Replace the control device
27	Not used		
28	Not used		
29	Operating temperature out of range	Operating temperature below -40°C or above 70°C	Bring the control device within the specified temperature nominal values
30	Code memory fault	Internal fault	Replace the control device
31	FR: external short circuit	External short circuit between T24 and EARTH	Inspect the flame detection electrode
32	Check mode timeout (manual)	The interval for the manual mode (30 minutes) to end has elapsed	Exit the manual mode correctly to avoid timeout
33	False flame in stand-by mode	Unexpected flame (false or parasitic flame) detected during the Stand-by status	Check flame sensor or interference
34	Not used		
35	Internal processor timeout	Internal fault	Replace the control device
36	Internal processor timeout	Internal fault	Replace the control device
37	Combustion air check timeout	The system could not perform verification tests of the combustion air during the burner sequence	Check the wiring or the air pressure switch
38	Internal processor timeout	Internal fault	Replace the control device
39	Internal processor timeout	Internal fault	Replace the control device
40	Internal hardware fault	Internal fault	Replace the control device
41	Internal hardware fault	Internal fault	Replace the control device
42	Main processor fault	Internal fault	Replace the control device
43	Supervisor processor fault	Internal fault	Replace the control device
44	Supervisor processor timeout	Internal fault	Replace the control device
45	Off-specification mains voltage	Off-specification mains voltage/frequency	Check the mains voltage level or the frequency. Contact the factory if the problem persists
46	Off-specification mains voltage	Off-specification mains voltage/frequency	Check the mains voltage level or the frequency. Contact the factory if the problem persists
47	UV: Internal fault	Internal fault	Replace the control device
48	Supervisor processor fault	Internal fault	Replace the control device
49	Main processor fault	Internal fault	Replace the control device
50	Ignition feedback fault	The system detected the presence of voltage on T16 at the wrong moment or there is no voltage when necessary	Check the wiring and make sure that the earthing is appropriate If the problem persists, contact the distributor/factory
51	Pilot feedback fault	The system detected the presence of voltage on T17 at the wrong moment or there is no voltage when necessary	Check the wiring and make sure that the earthing is appropriate. If the problem persists, contact the distributor/factory
52	Piloted valve feedback fault	The system detected the presence of voltage on T19 at the wrong moment or there is no voltage when necessary	Check the wiring and make sure that the earthing is appropriate If the problem persists, contact the distributor/factory
53	Actuator feedback waiting time expired	No actuator feedback on T8 for more than 10 minutes	Check the wiring Check the modulation equipment
54	Direct ignition valve feedback fault	The system detected the presence of voltage on T18 at the wrong moment or there is no voltage when necessary	Check the wiring and make sure that the earthing is appropriate. If the problem persists, contact the distributor/factory

No.	Faults	Cause	Solution
55	Internal processor fault	Internal fault	Replace the control device
56	UV: false flame during operation	False flame detected before ignition	Check the flame sensor
57	FR: false flame during operation	False flame detected before ignition	Check the wiring Check the flame sensor Make sure that earthing is appropriate
58	T8 inlet fault	The system detected the presence of voltage on T8 at the wrong moment or there is no voltage when necessary	Check the wiring Check the actuator
59	Internal hardware fault	Internal fault	Replace the control device
60	Local reset fault	Local reset button pressed for more than 10 seconds or reset button locked	If the problem persists, replace the control device
61	Open POC fault	The fuel valve is open at the wrong moment	Check the wiring
62	UV: strong UV flame fault	The flame sensor is too close to the flame	Increase the distance between the sensor and the flame OR use an orifice to reduce the view field
63	Internal hardware fault	Internal fault	Replace the control device

Tab. P

A Appendix - Accessories**Kit for modulating operation**

The parts to be ordered are two:

- output regulator to be installed to the burner;
- probe to be installed to heat generator.

Parameter to be controlled		Probe		Output regulator	
Adjustment field		Type	Code	Type	Code
Temperature	- 100...+ 500 °C	PT 100	3010110	RWF50 RWF55	20082208 20099657
Pressure	0...2.5 bar	Output probe 4...20 mA	3010213		
	0...16 bar		3010214		

Soundproofing box kit

Burner	Type	dB(A)	Code
All models	C4/5	10	3010404

Degasser kit

Burner	Filter	Code
All models	with filter	3010055
All models	without filter	3010054

Spacer kit

Burner	Code
All models	3010129

Potentiometer kit

Burner	Code
All models	3010021

B Appendix - Electrical panel layout

1	Index of layouts
2	Reference indication
3	Functional layout RFGO-A23
4	Functional layout RFGO-A23
5	Functional layout RFGO-A23
6	Electrical wiring that is the responsibility of the installer
7	Electrical wiring that is the responsibility of the installer
8	Functional layout RWF

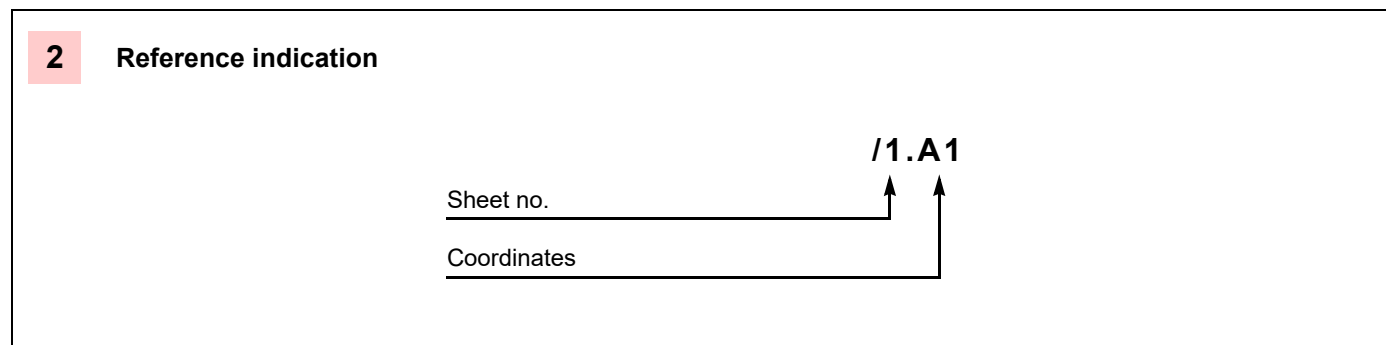

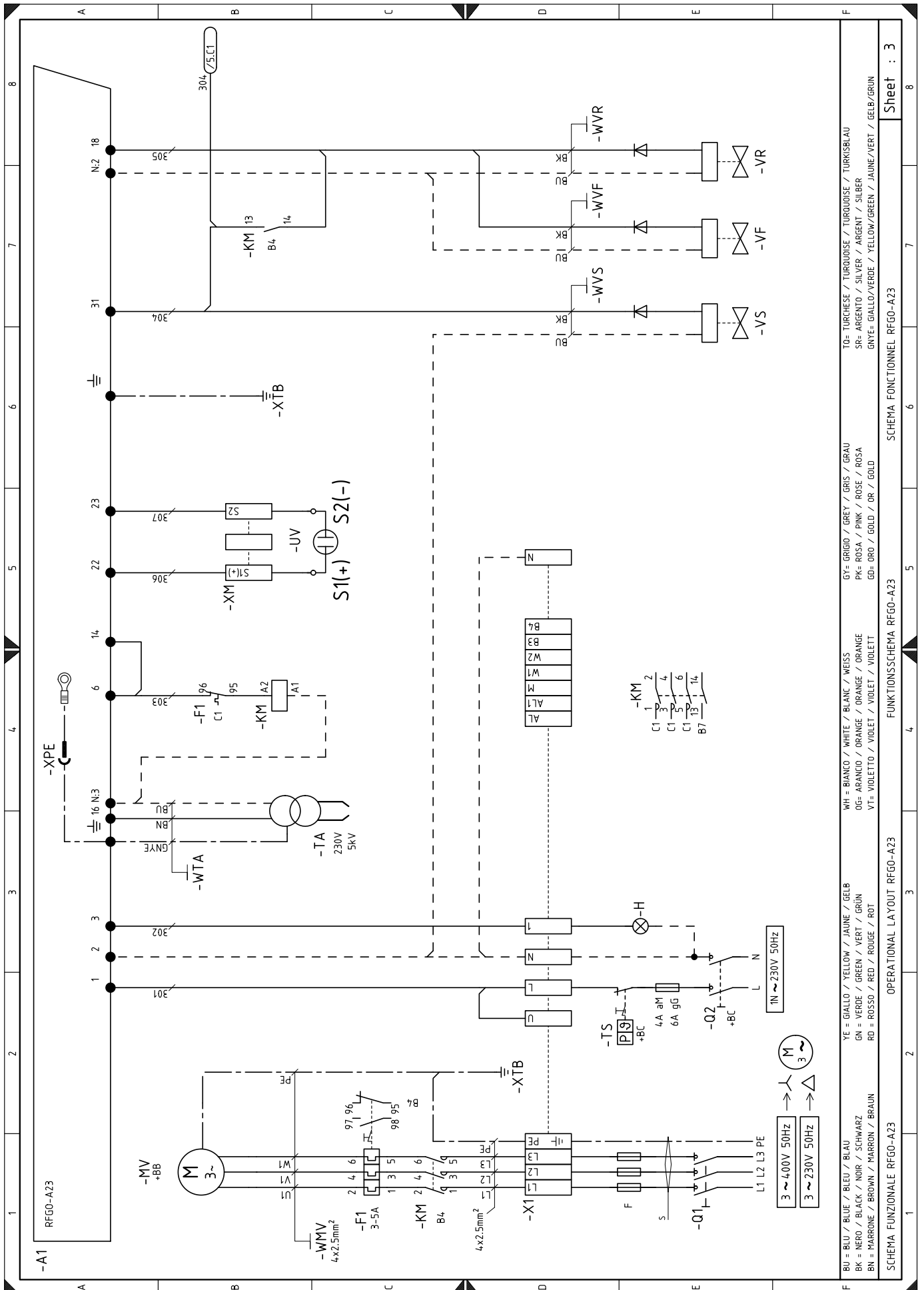

BU = BLU / BLUE / BLEU / BLAU
 BK = NERO / BLACK / NOIR / SCHWARZ
 BN = MARRONE / BROWN / MARRON / BRAUN
 YE = GIALLO / YELLOW / JAUNE / GELB
 GN = VERDE / GREEN / VERT / GRÜN
 RD = ROSSO / RED / ROUGE / ROT
 WH = BIANCO / WHITE / BLANC / WEISS
 OG = ARANCIO / ORANGE / ORANGE / ORANGE
 VF = VIOLETTA / VIOLET / VIOLET / VIOLETT
 GY = GRIGIO / GREY / GRIS / GRAU
 PK = ROSA / PINK / ROSE / ROSA
 GD = ORO / GOLD / OR / GOLD
 IO = TURCHESE / TURQUOISE / TURQUOISE / TURKISBLAU
 SR = ARGENTO / SILVER / ARGENT / SILBER
 GNVE = GIALLO/VERDE / YELLOW/GREEN / JAUNE/VERT / GELB/GRÜN

SCHEMA FUNZIONALE RFG0-A23
 OPERATIONAL LAYOUT RFG0-A23
 FUNKTIONSSCHHEMA RFG0-A23
 SCHEMA FONCTIONNEL RFG0-A23
 Sheet : 3

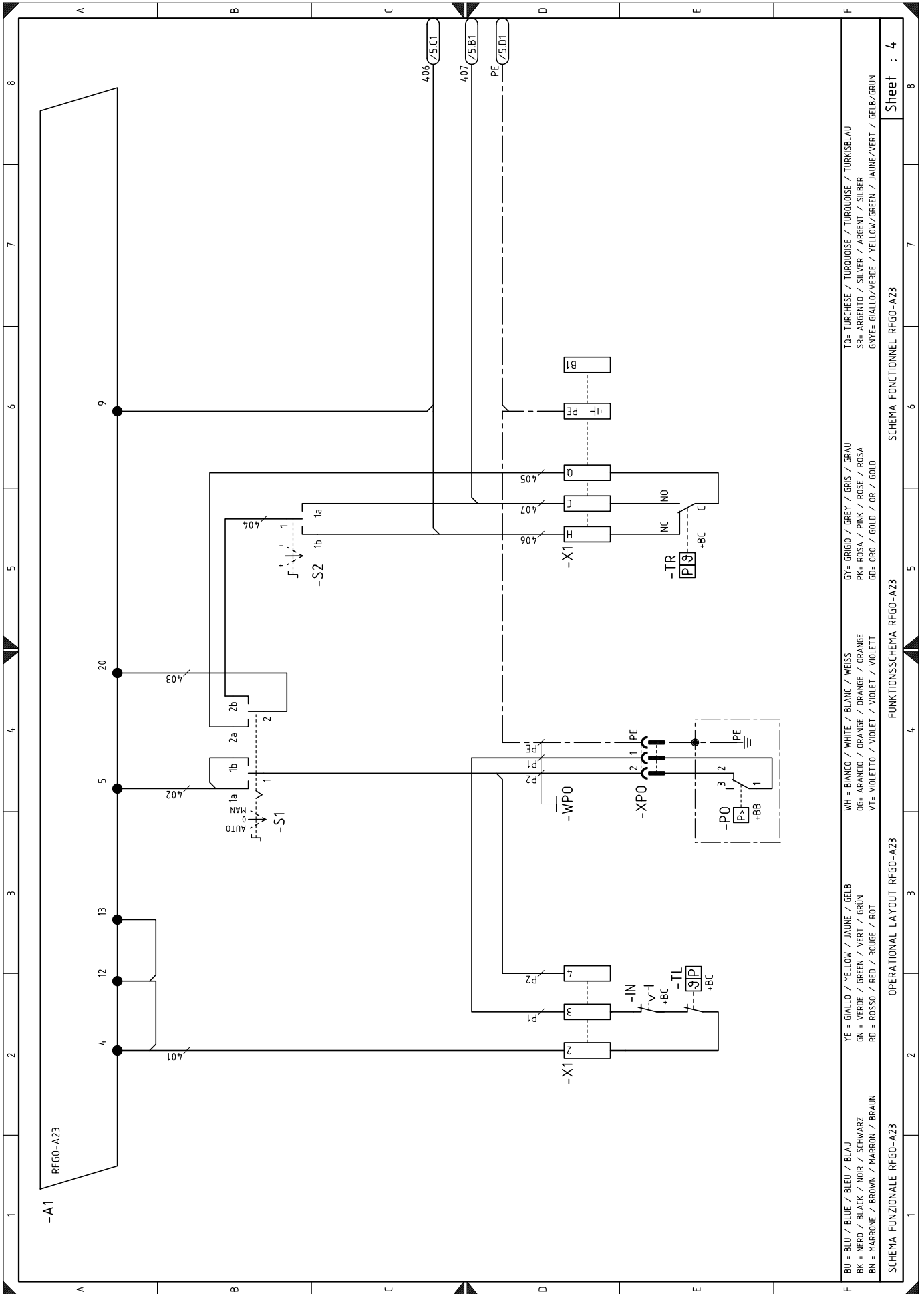

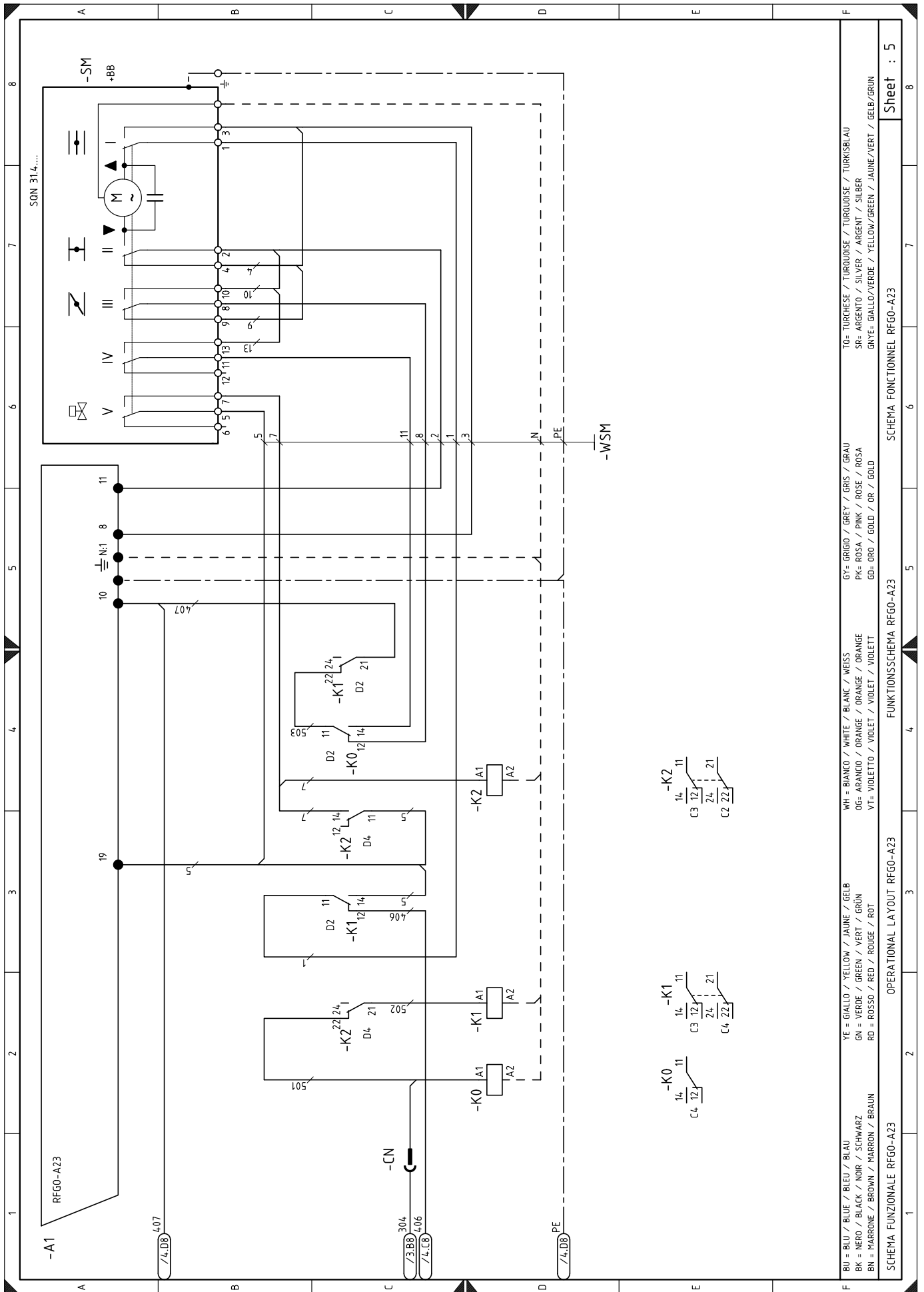

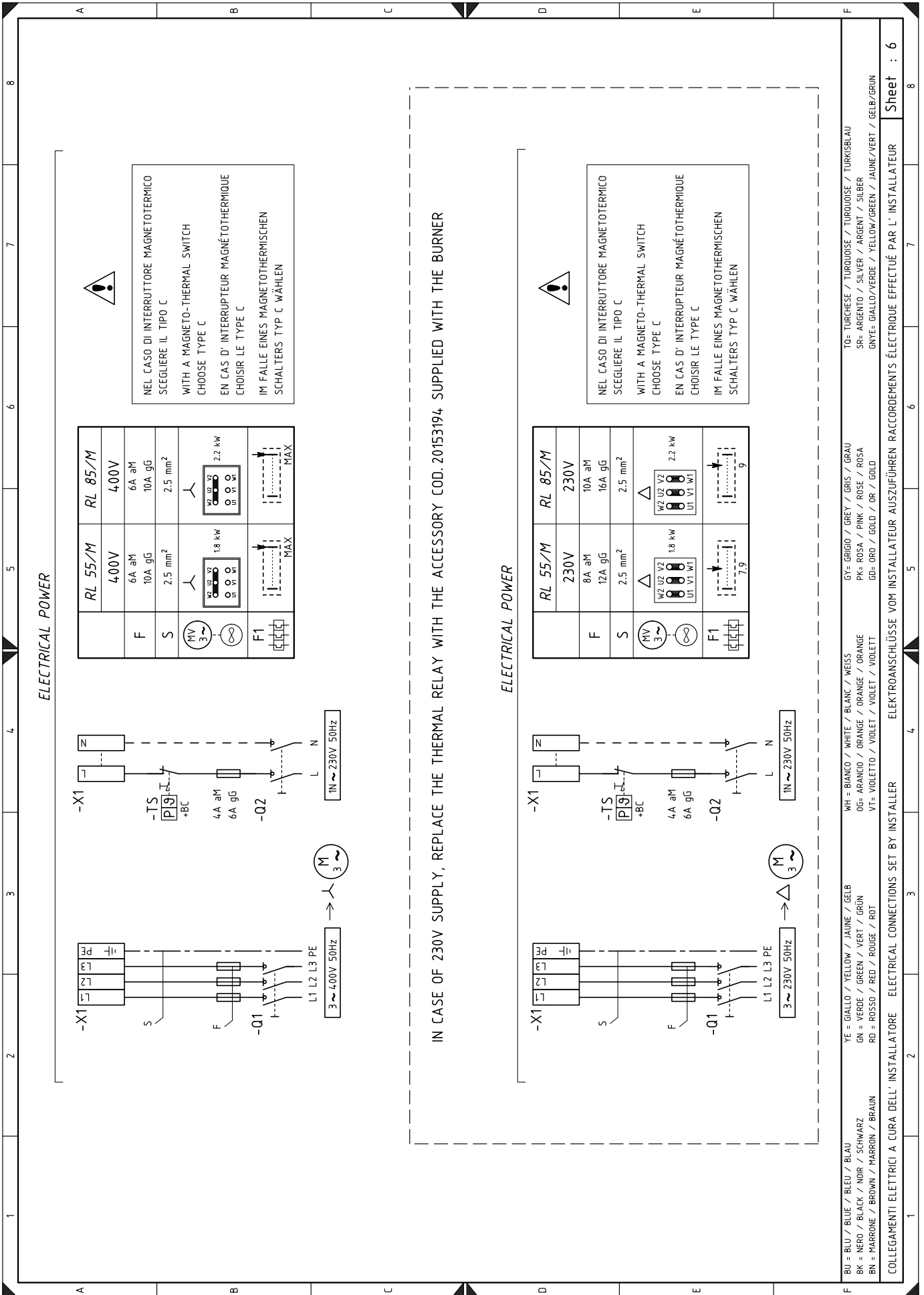

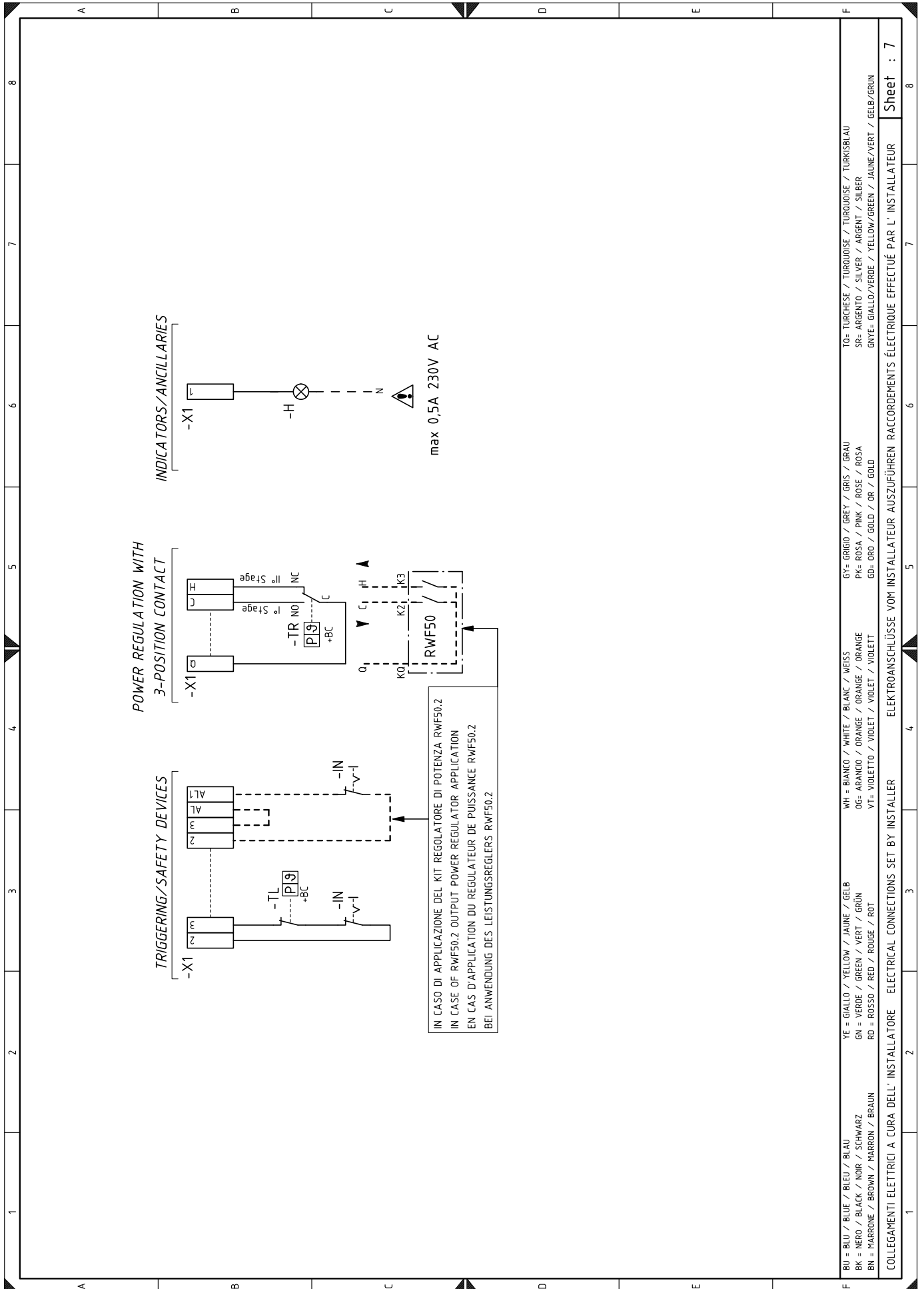

WIRING DIAGRAM KEY

A1	Control box
B1	RWF Output power regulator
BA	Probe with output under current
BA1	Device with output under current for change of remote setpoint
BP	Pressure probe
BP1	Pressure probe
BR	Remote setpoint potentiometer
BT1	Thermocouple probe
BT2	Probe Pt100, 2 wires
BT3	Probe Pt100, 3 wires
BT4	Probe Pt100, 3 wires
BTEXT	External probe for climatic compensation of the setpoint
BV	Probe with output under voltage
BV1	Device with output under voltage for change of remote setpoint
CN	Servomotor connector
F	Three-phase line fuses
F1	Fan motor thermal relay
H	Remote lockout signalling
IN	Burner manual stop switch
KO	Relay
K1	Relay
K2	Relay
KM	Fan motor contactor
FM	Fan motor
Q1	Three-phase line disconnecting switch
Q2	Single-phase line disconnecting switch
S1	Off / automatic / manual switch
S2	Button for - = power reduction + = power increase
SM	Servomotor
TA	Ignition transformer
TL	Limit thermostat/pressure switch
TR	Adjustment thermostat/pressure switch
ST	Safety thermostat
X1	Terminal board
XS	Flame sensor terminal board
XPE	Control box earth
XTB	Burner earth
UV	UV Flame sensor
PO	Oil pressure switch
XPO	Oil pressure switch connector
VS	Safety valve
VF	Working valve
VR	Adjustment valve

RIELLO

RIELLO S.p.A.
I-37045 Legnago (VR)
Tel.: +39.0442.630111
[http:// www.riello.it](http://www.riello.it)
[http:// www.riello.com](http://www.riello.com)