

# CS200 Series Commercial / Industrial Pressure Reducing Regulators

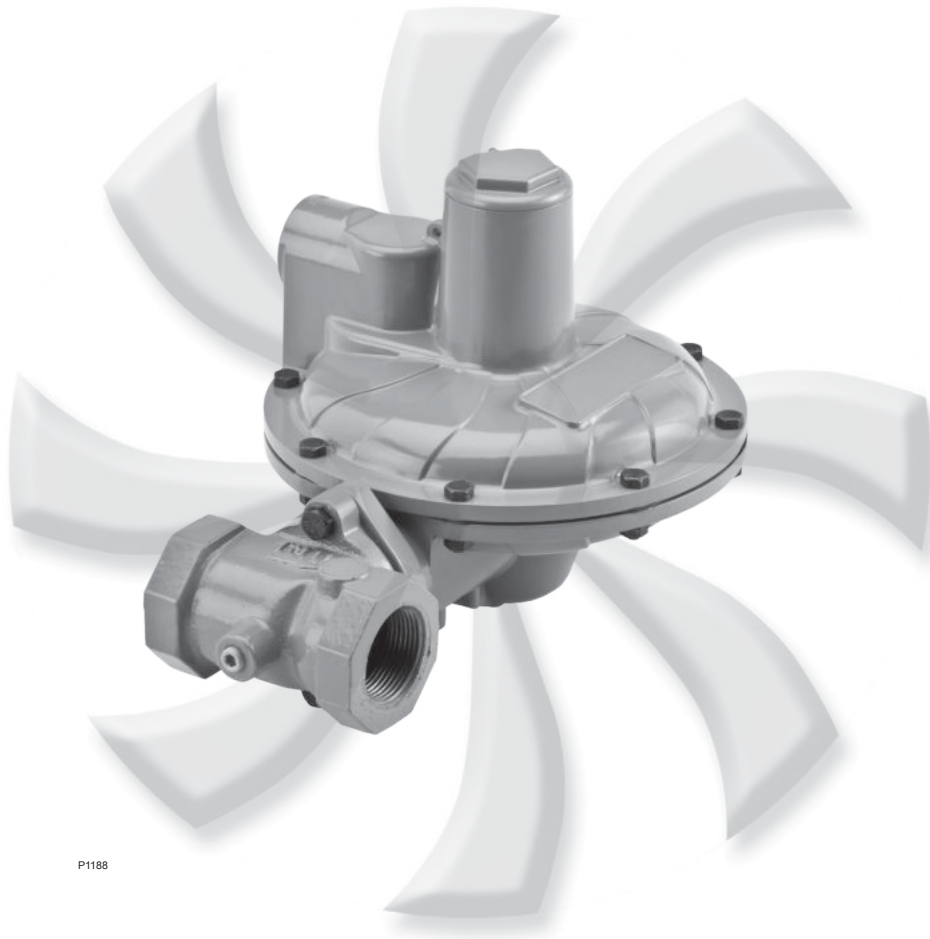

P1188

*Figure 1. Typical CS200 Series Pressure Reducing Regulator*

## Features and Benefits

- Wide Range of Body Sizes and End Connections
- Easy to Install and Maintain
- Only Standard Tools Required for Pressure Adjustment and Orifice Removal
- Fixed Factor Accuracy (PFM Approved)
- Application Flexibility including Internal Relief, Non-Relieving, and Secondary Seat™ Protection
- Secondary Seat Protection provides a secondary seating and disk surface in the event that damage to the primary disk or orifice seat or debris in the flow path inhibit lockup



[www.fisherregulators.com](http://www.fisherregulators.com)



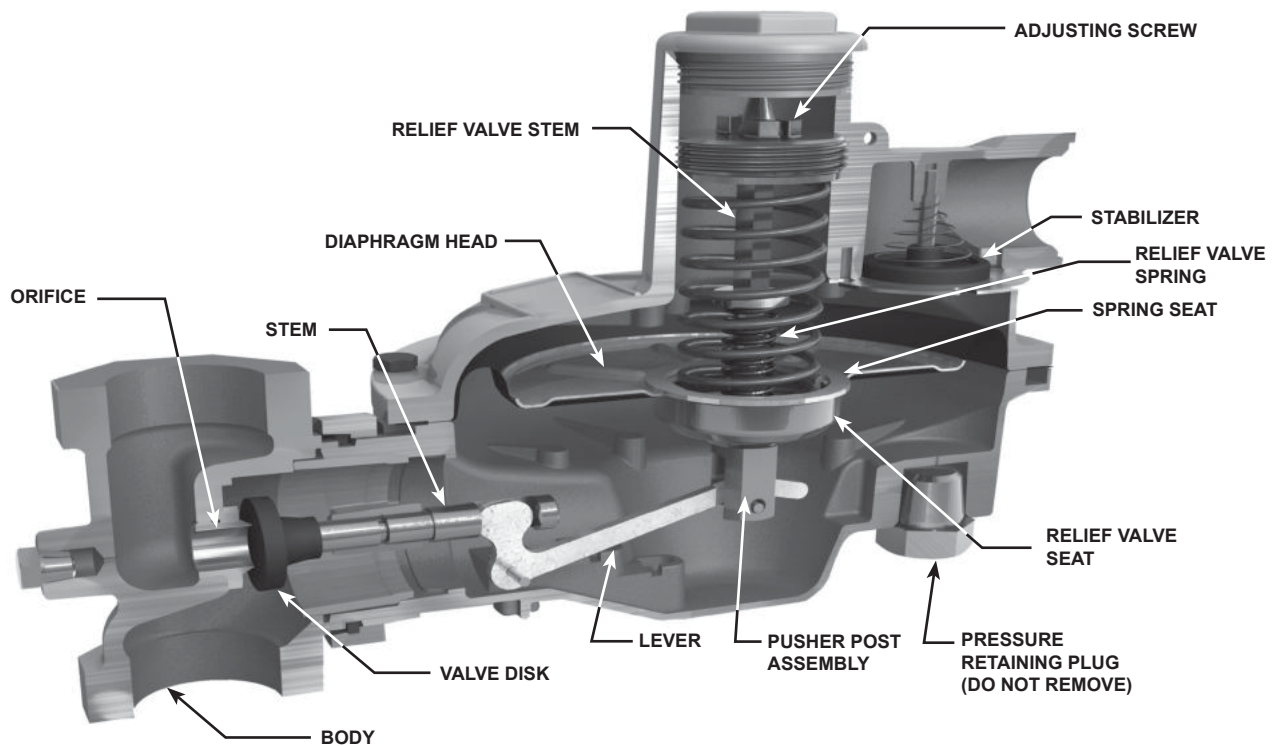

*Figure 2. Typical CS200 Series Pressure Reducing Regulator Cut-Away View*

## Introduction

The CS200 Series direct-operated, spring-loaded regulators have been engineered to fit a multitude of pressure-reducing applications including commercial and industrial installations. This flexibility is provided by the numerous body sizes, outlet pressure settings, and orifice sizes. Ease of maintenance and installation is also a strength of the CS200 Series, which offers a full 360-degree of rotation of the actuator via the union ring connection between the body and casing. The combination of 360-degree rotatable union ring along with a rotatable upper casing provide simplified vent position, especially in tight spaces or awkward installations.

The CS200 Series also offers Overpressure Protection in the form of Internal Relief and Secondary Seat™ Protection.

## Overpressure Protection Options Available:

- **Internal Relief** – Relieves gas across the main diaphragm assembly to minimize downstream pressure buildup.
- **Secondary Seat™ Protection** – provides lockup via a secondary seating and disk surface in the event that damage to the primary disk or orifice seating surface, or debris in the flow path, inhibit primary lockup. Secondary Seat Protection does not provide additional overpressure protection in the event the secondary seat or disk is damaged by debris or contamination in the pipeline or from conditions that would cause the regulator to go wide open. See page 6 for additional information.

## Specifications

### Available Configurations

**Type CS200IN:** Basic construction with Internal pressure registration and Non-Relieving diaphragm assembly

**Type CS200IR:** Basic construction with Internal pressure registration and Relieving diaphragm assembly

**Type CS205IN:** Type CS200IN with Secondary Seat™ Protection

**Type CS205IR:** Type CS200IR with Secondary Seat Protection

**Type CS206IR:** Type CS200IR with Secondary Seat Protection with bleed to indicate Secondary Seat is functioning  
See also Table 1

### Body Sizes, Material, End Connections, and Pressure Rating<sup>(1)</sup>

See Table 2

### Inlet Pressure Ratings<sup>(1)</sup>

See Table 3

### Maximum Outlet Pressure<sup>(1)</sup>

**Casing:** 25 psig / 1.7 bar

**To Avoid Internal Parts Damage:**  
5 psig / 0.34 bar differential above outlet pressure setting

**Operating:** 2 psig / 138 mbar

### Outlet Pressure Ranges

3.5 inches w.c. to 2 psig / 9 to 138 mbar

### Internal Relief Performance

#### Approximate Internal Relief Start-to-Discharge:

See Table 5

#### Secondary Seat Approximate Lockup Values:

See Table 6

### Relief Performance:

See Figures 7 to 10 and Tables 8, 11, 16, and 21

### Flow Capacities

See Tables 7, 9 to 10, 12 to 15, 17 to 20, and 22 to 33

### Flow and IEC Sizing Coefficients

See Table 3

### Orifice Sizes

See Table 3

### Temperature Capabilities<sup>(1)(2)</sup>

-20 to 150°F / -29 to 66°C

### Spring Case Vent Connection

1 NPT

### Body Positions and Spring Case Vent Locations

See Figure 9

### Inlet Pressure Tap

1/4 NPT restricted to 0.054 inch / 1.4 mm

### Construction Materials

**Body:** Gray cast iron

**Body O-ring:** Nitrile (NBR)

**Closing Cap:** Aluminum

**Adjusting Screw:** Aluminum

**Diaphragm Case, Spring Case, and Valve Stem:** Aluminum

**Diaphragm Head:** Steel

**Orifice:** Aluminum

**Orifice with Secondary Seat Protection:**  
Brass and Nitrile (NBR)

**Pusher Post:** Aluminum

**Diaphragm and Disk:** Nitrile (NBR)

**Control Spring:** Stainless steel or Music wire

**Relief Valve Spring:** Stainless steel

**Relief Valve Spring Retainer:** Aluminum

**Vent Screen:** Stainless steel

**Vent Screen Retaining Ring:** Zinc-plated steel

**Lever Pin:** Stainless steel

**Spring Seat:** Zinc-plated steel

**Lever, Other Metal Parts:** Steel

### Approximate Weight

8 pounds / 4 kg

### Designed, Tested, and Evaluated consistent with:

ASME B16, ASME Section VIII DIV I, ASTM B117  
(Corrosion Resistance)

1. The pressure/temperature limits in this Bulletin or any applicable standard limitation should not be exceeded.

2. Product has passed Emerson Process Management Regulator Technologies, Inc. (Regulator Technologies), testing for lockup, relief start-to-discharge, and reseal down to -40°.

# Bulletin 71.1:CS200

**Table 1. Available Configuration**

TYPE NUMBER					OPTIONS	
C	S	2	0			
						<b>OVERPRESSURE PROTECTION MODULE</b>
				0		Without Overpressure Protection Module
				5		With Secondary Seat™ Protection
				6		With Secondary Seat Protection with bleed to indicate Secondary Seat is functioning
						<b>PRESSURE REGISTRATION</b>
				I		Internal Registration
						<b>RELIEF</b>
					N	Non-Relief
					R	Internal Relief

**Table 2. Body Sizes, Material, End Connection, and Pressure Rating**

SERIES	BODY SIZE, NPS	END CONNECTION	BODY MATERIAL	PRESSURE RATING	
				psig	bar
CS200	3/4 3/4 x 1 3/4 x 1-1/4 1 1 x 1-1/4 1-1/4	NPT	Gray Cast Iron	175	12.1

**Table 3. Inlet Pressure Ratings and Flow and Sizing Coefficients**

TYPE	ORIFICE SIZE		MAXIMUM OPERATING INLET PRESSURE TO OBTAIN OPTIMUM PERFORMANCE <sup>(1)(2)</sup>		MAXIMUM EMERGENCY INLET PRESSURE <sup>(2)</sup>		FLOW COEFFICIENTS (WIDE-OPEN)		C <sub>1</sub>	IEC SIZING COEFFICIENTS		
	Inch	mm	psig	bar	psig	bar	C <sub>g</sub>	C <sub>v</sub>		X <sub>T</sub>	F <sub>D</sub>	F <sub>L</sub>
CS200	1/8	3.2	125	8.6	175	12.1	12	0.4	30	0.53	0.87	0.89
	3/16	4.8	125	8.6			24	0.8	30	0.58	0.82	
	1/4	6.4	125	8.6			44	1.52	29	0.53	0.85	
	3/8	9.5	60	4.1			102	3.3	31	0.6	0.83	
	1/2	13	40	2.8			172	4.4	39	0.97	0.72	
CS205 and CS206	1/8	3.2	125	8.6	175	12.1	17	0.6	28	0.5	0.82	0.89
	3/16	4.8	125	8.6			37	1.4	27	0.49	0.8	
	1/4	6.4	125	8.6			65	2.2	30	0.5	0.8	
	5/16	7.9	100	6.9			88	2.7	33	0.65	0.79	

1. Inlet pressures based on lock-up performance. For maximum inlet pressure values with optimum regulating performance refer to the applicable Flow Capacity table.  
 2. To comply with ANSI B109.4 relief requirements, the maximum inlet pressure may need to be reduced. Reference the Relief Performance Tables 8, 11, 16, and 21.

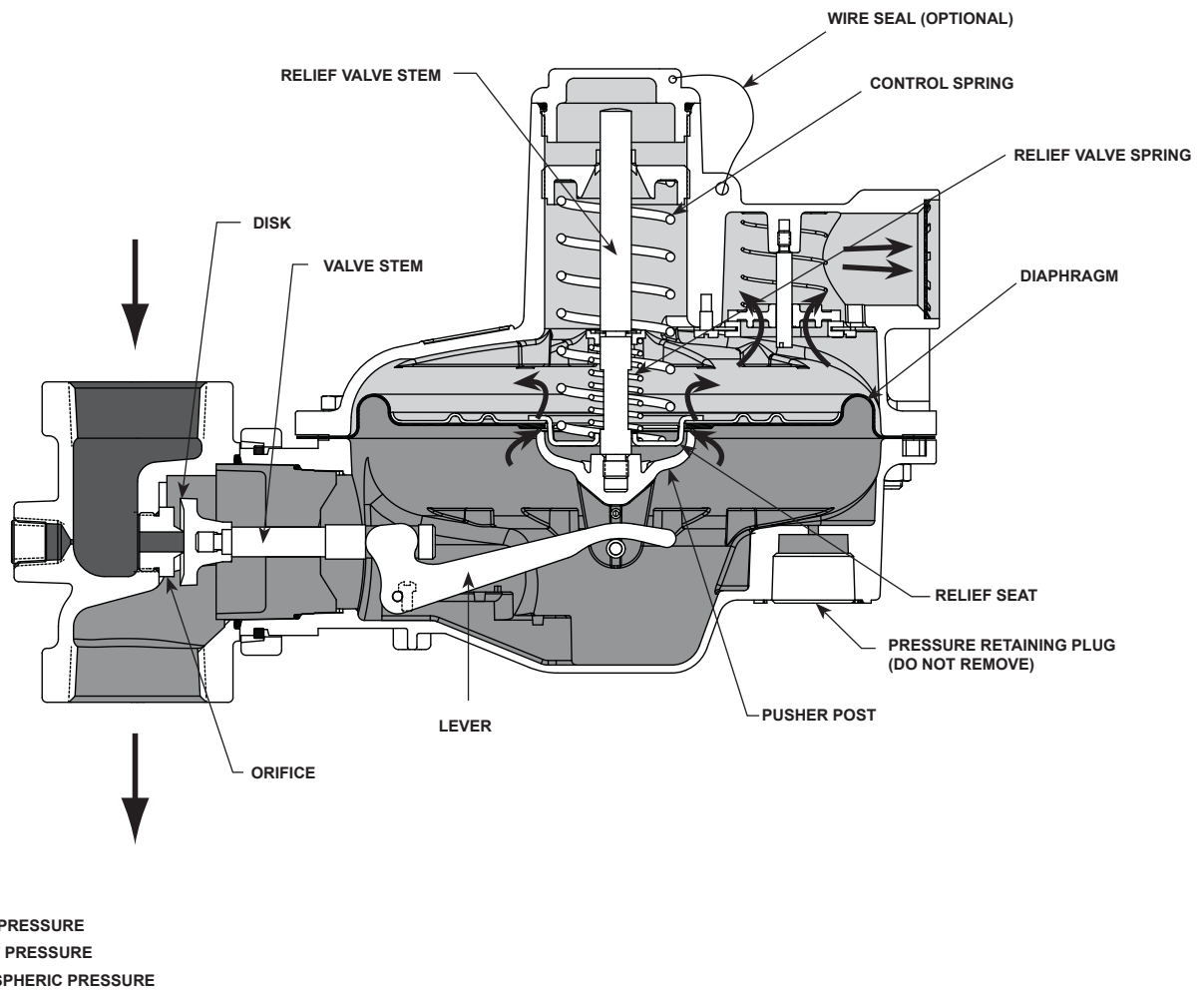

Figure 3. Type CS200IR Pressure Reducing Regulator with Internal Relief

## Principle of Operation

### Type CS200 Base Regulator Operation

Refer to Figure 3. When downstream demand decreases, the pressure under the diaphragm increases. This pressure overcomes the regulator setting (which is set by the control spring). Through the action of the pusher post assembly, lever, and valve

stem, the valve disk moves closer to the orifice and reduces gas flow. If demand downstream increases, pressure under the diaphragm decreases. Spring force pushes the pusher post assembly downward and the valve disk moves away from the orifice.

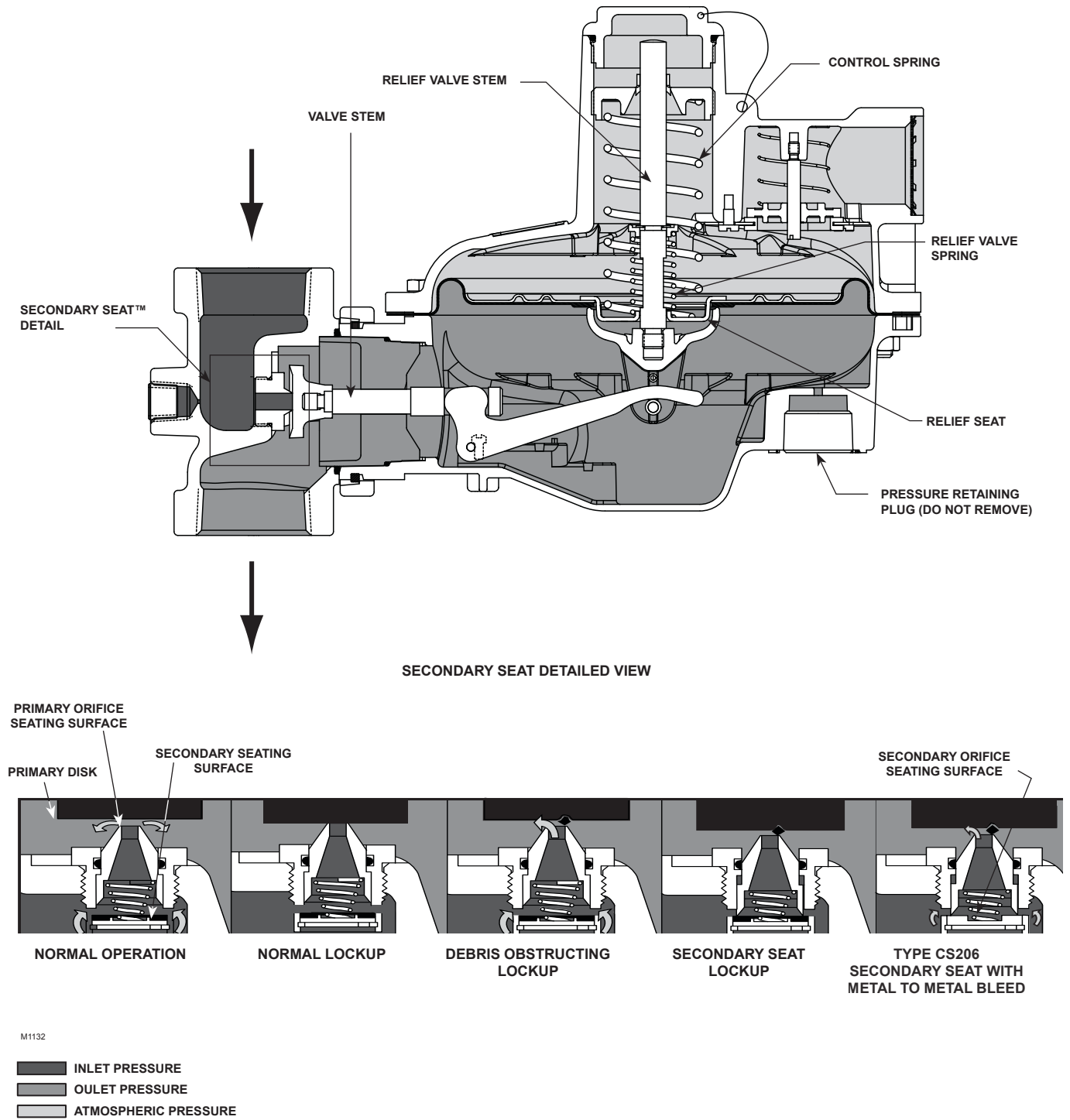

Figure 4. CS200 Series with Secondary Seat Protection

## CS200 Series with Internal Relief

Refer to Figure 3. The option for internal relief is offered on the Types CS200 and CS205 and is standard on the Type CS206. Internal relief is used to help minimize overpressure. Any outlet pressure above the start-to-discharge point of the non-adjustable relief spring moves the diaphragm off of the relief seat, allowing excess pressure to discharge through the vent. For approximate start-to-discharge values, see Table 5. If emergency conditions should exist that prevent normal operation of the regulator or internal relief valve, the relief valve stem acts as a secondary travel stop contacting the underside of the closing cap and stopping the upward travel of the relief seat. Since the diaphragm continues to rise as downstream pressure builds, the diaphragm lifts off of the relief seat to provide relief operation. See Figures 5 through 8 for Relief Capacity data.

## Type CS205 with Secondary Seat™ Protection

Refer to Figure 4. The Type CS205 provides Secondary Seat Protection. As downstream demand decreases and downstream pressure rises to the regulator pressure lock-up value, the regulator will lock up. If, however, damage has occurred to the primary disk, to the primary orifice's seating surface, or debris has become lodged between the primary disk and primary orifice, the outlet pressure will continue to rise. This additional pressure causes the primary disk to apply additional force to the orifice seating surface, which causes the secondary seating surface to move toward the secondary disk or sealing surface. If downstream demand decreases to zero, then the secondary seating surface will contact the sealing surface to provide lockup. Refer to Table 6 for approximate lock-up values provided by the Secondary Seat.

## Type CS206 Secondary Seat Protection with Bleed

The Type CS206 provides small bleed to the downstream system as an indication that the Secondary Seat is providing lockup. In the event that the primary orifice and disk can not provide lockup, the secondary seating surface will move into contact with a metal disk. This metal to metal interface will allow a small amount of gas to bleed downstream thereby increasing

outlet pressure until the Internal relief valve begins to discharge gas to the atmosphere. The odor of this discharged gas provides an indication that the regulator is relying on the Secondary Seat for overpressure protection. See Table 6 for the Downstream Pressure Buildup of the Internal relief acting in conjunction with the Type CS206 Secondary Seat Assembly.

## Types CS205 and CS206 Secondary Seat Protection Limitations

Secondary Seat Protection does not provide additional overpressure protection in the event the secondary seating surface or disk is damaged by debris or contamination in the pipeline or from conditions that would cause the regulator to go wide open. When selecting Secondary Seat Protection option, it is recommended that:

- Other additional overpressure protection methods be added in the downstream system as discussed in the section on Overpressure Protection; and
- An annual downstream lock-up pressure test be done to determine if the Secondary Seat Protection option is operating and functional

## Installation

The CS200 Series regulators may be installed in any position. However, the spring case vent should be pointed downward. If gas escaping through the CS200 Series internal relief valve could constitute a hazard, the spring case vent must be piped to a location where escaping gas will not be hazardous. If the vented gas will be piped to another location, use obstruction-free tubing or piping at least equal in size to the vent, and the end of the vent pipe must be protected from anything that might restrict or clog it. Dimensions are shown in Figure 10.

## Overpressure Protection

The CS200 Series regulators have outlet pressure ratings lower than the inlet pressure ratings. Additional downstream overpressure protection is needed and sized for wide-open capacity discharge if the actual inlet pressure exceeds the outlet pressure rating.



# Bulletin 71.1:CS200

**Table 4. Outlet Pressure Ranges**

TYPE	OUTLET PRESSURE RANGE		PART NUMBER	SPRING COLOR	SPRING WIRE DIAMETER		SPRING FREE LENGTH	
	Inch w.c.	mbar			Inch	mm	Inch	mm
CS200	3.5 to 5	9 to 12	GE30198X012	Red	0.102	2.59	3.95	100
	4.5 to 6.5	11 to 16	GE30195X012	Purple	0.090	2.28	4.32	110
	6 to 8	15 to 20	GE30188X012	Gold	0.111	2.82	4.48	114
	7.5 to 11	19 to 27	GE30189X012	Blue	0.112	2.84	4.40	112
	10 to 14	25 to 35	GE30224X012	Unpainted	0.102	2.59	4.78	121
	12 to 19	30 to 47	GE30196X012	Green	0.112	2.84	4.70	119
	18 to 1 psig	45 to 69	GE30225X012	Orange	0.120	3.04	4.94	125
	1 to 2 psig	69 to 138	GE30190X012	Black	0.145	3.68	4.66	118

**Table 5. Types CS200 and CS205 Approximate Internal Relief Valve Start-to-Discharge Pressure Above Setpoint**

SETPOINT		SPRING COLOR	SPRING PART NUMBER	START-TO-DISCHARGE PRESSURE RANGE ABOVE SETPOINT			
psig	mbar			TYPE CS200		TYPE CS205	
				psi	mbar	psi	mbar
7 inches w.c.	17	Gold	GE30188X012	6 to 12 inches w.c.	15 to 30	11 to 16 inches w.c.	27 to 40
11 inches w.c.	27	Blue	GE30189X012	7 to 13 inches w.c.	17 to 32	11 to 16 inches w.c.	27 to 40
14 inches w.c.	35	Unpainted	GE30224X012	8 to 14 inches w.c.	20 to 35	13 to 19 inches w.c.	32 to 47
1	69	Orange	GE30225X012	0.3 to 1.5	21 to 103	1 to 1.8	69 to 124
2	138	Black	GE30190X012	0.3 to 1.5	21 to 103	1 to 1.8	69 to 124

**Table 6. Secondary Seat™ Outlet Pressures**

CONTROL SPRING		SPRING RANGE		SETPOINT		TYPE CS205		TYPE CS206	
Color	Spring Part Number	Inch w.c.	mbar	Inch w.c.	mbar	Secondary Seat Shutoff above Setpoint <sup>(1)(2)</sup>		Downstream Pressure Buildup <sup>(2)</sup>	
						Inch w.c.	mbar	Inch w.c.	mbar
Gold	GE30188X012	6 to 8	15 to 20	7	17	5	12	25.1	62
Blue	GE30189X012	7.5 to 11	19 to 27	11	27	5.5	14	29.6	74
Unpainted	GE30224X012	10 to 14	25 to 35	14	35	5.8	14	1.26 psig	87
Orange	GE30225X012	18 to 1 psig	45 to 69	1 psig	69	7.8	19	1.90 psig	131
Black	GE30190X012	1 to 2 psig	69 to 138	2 psig	138	13	32	3.42 psig	236

1. Shutoff with primary orifice / seating surface disabled.  
 2. Shutoff and buildup per ANSI B109.4 at 125 psig / 8.6 bar inlet pressure.



## Internal Relief

The internal relief provided by the Type CS200IR limits the total outlet pressure to values shown in Relief Tables 8, 11, 16, and 21. This internal relief may be adequate, however, if an additional pressure relief is required to maintain downstream pressure at the desired maximum level, an additional relieving or pressure limiting device should be installed to protect downstream equipment.

Overpressuring any portion of a regulator or associated equipment may cause leakage, parts damage, or personal injury due to bursting of pressure-containing parts or explosion of accumulated gas. Regulator operation within ratings does not preclude the possibility of damage from external sources or from debris in the pipeline. A regulator should be inspected for damage periodically and after any overpressure condition.

Refer to the relief sizing coefficients. Table 3, and the Capacity Information section to determine the required relief valve capacity.

## Internal Relief Per ANSI B109.4

The ANSI B109.4 standard applies to outlet setpoints at or below 14-inches w.c. / 35 mbar. At these conditions the maximum outlet pressure allowed during relief is 2 psig / 138 mbar. If the Type CS200IR installation requires conformance with the ANSI B109.4, then the maximum inlet pressure allowed per orifice is limited to the value that maintains an outlet below 2 psig / 138 mbar during relief. Reference applicable relief capacity curves, Figures 5 through 8, to determine maximum allowable inlet per orifice.

Flows are in SCFH (60°F and 14.7 psia) and Nm<sup>3</sup>/h (0°C and 1.01325 bar) of 0.6 specific gravity natural gas. To determine equivalent capacities for air, propane, butane, or nitrogen, multiply the capacity number in the tables by the following appropriate conversion factor: 0.775 for air, 0.628 for propane, 0.548 for butane, or 0.789 for nitrogen. For gases of other specific gravities, multiply the given capacity by 0.775 and divide by the square root of the appropriate specific gravity.

The published capacities were obtained using inlet and outlet piping the same size as the regulator body size.

## Relief Sizing

### For Critical Flow:

To determine wide-open flow capacities for relief sizing of 0.6 specific gravity natural gas at 60°F at critical pressure drops (absolute outlet pressure equal to approximately one-half or less than one-half of the absolute inlet pressure), use the following formula:

$$Q = P_{1abs}(C_g)(1.29)$$

### For Subcritical Flow:

If pressure drops are lower than critical (absolute outlet pressure greater than approximately one-half the absolute inlet pressure), use the following formula and convert according to the factors in the preceding paragraph if necessary:

$$Q = \sqrt{\frac{520}{GT}} C_g P_1 \text{SIN} \left( \frac{3417}{C_1} \sqrt{\frac{\Delta P}{P_1}} \right) \text{DEG}$$

where:

- $C_1 = C_g/C_v$  (See Table 2)
- $C_g$  = Gas sizing coefficient (See Table 3)
- $G$  = Gas specific gravity (air = 1.0)
- $P_1$  = Regulator inlet pressure, psia
- $\Delta P$  = Pressure drop across regulator, psi
- $Q$  = Gas flow rate, SCFH
- $T$  = Absolute temperature of gas at inlet, °Rankine

## Capacity Information

Tables 7, 9 to 10, 12 to 15, 17 to 20, and 22 to 32 give the CS200 Series natural gas regulating capacities at selected inlet pressures, outlet pressure settings, and body outlet sizes.

# Bulletin 71.1:CS200

**Table 7. CS200IN and CS200IR Series Flow Capacities for 7-inches w.c. / 17 mbar Setpoint**

SETPPOINT	ACCURACY		SET RANGE	SPRING PART NUMBER / COLOR
	Droop	Boost		
7 inches w.c.	-1 inch w.c.	2 inches w.c.	6 to 8 inches w.c.	GE30188X012 / Gold
17 mbar	-2 mbar	5 mbar	15 to 20 mbar	

CAPACITIES IN SCFH / Nm <sup>3</sup> /h OF 0.6 SPECIFIC GRAVITY NATURAL GAS											
Inlet Pressure		Orifice Size, Inch / mm									
		1/8 / 3.2		3/16 / 4.8		1/4 / 6.4		3/8 / 9.5		1/2 / 13	
		SCFH	Nm <sup>3</sup> /h	SCFH	Nm <sup>3</sup> /h	SCFH	Nm <sup>3</sup> /h	SCFH	Nm <sup>3</sup> /h	SCFH	Nm <sup>3</sup> /h
psig	bar	Body Size: NPS 3/4									
0.5	34 mbar	60	1.6	120	3.2	170	4.6	225	6.0	300	8.1
1	69 mbar	100	2.7	175	4.7	300	8.1	350	9.4	425	11.4
2	138 mbar	130	3.5	250	6.7	325	8.7	525	14.1	625	16.8
3	0.21	160	4.3	325	8.7	400	10.7	600	16.1	825	22.1
5	0.34	220	5.9	425	11.4	675	18.1	925	24.8	1050	28.2
10	0.69	300	8.1	700	18.8	1025	27.5	1400	37.6	1400	37.6
15	1.0	375	10.1	900	24.2	1400	37.6	1675	45.0	1550	41.6
20	1.4	475	12.8	1050	28.2	1625	43.6	1825	49.0	1725	46.3
30	2.1	600	16.1	1375	36.9	1975	53.0	2000	53.7		
40	2.8	750	20.1	1700	45.6	2075	55.7	2000	53.7		
50	3.4	900	24.2	2025	54.4	2150	57.7	2000	53.7		
60	4.1	1050	28.2	2350	63.1	2200	59.1				
80	5.5	1350	36.2	2350	63.1	2250	60.4				
100	6.9	1650	44.3	2350	63.1						
125	8.6	2000	53.7								
psig	bar	Body Size: NPS 1									
0.5	34 mbar	60	1.6	120	3.2	170	4.6	240	6.4	300	8.1
1	69 mbar	100	2.7	175	4.7	300	8.1	400	10.7	425	11.4
2	138 mbar	130	3.5	250	6.7	400	10.7	575	15.4	775	20.8
3	0.21	160	4.3	325	8.7	475	12.8	750	20.1	1025	27.5
5	0.34	220	5.9	425	11.4	700	18.8	1100	29.5	1375	36.9
10	0.69	300	8.1	700	18.8	1150	30.9	1775	47.7	2075	55.7
15	1.0	375	10.1	900	24.2	1600	43.0	2300	61.7	2525	67.8
20	1.4	475	12.8	1050	28.2	1950	52.3	2650	71.1	2675	71.8
30	2.1	600	16.1	1375	36.9	2550	68.5	3325	89.3	3250	87.2
40	2.8	750	20.1	1375	36.9	3100	83.2	3775	101	3400	91.3
50	3.4	900	24.2	1375	36.9	1350	36.2	3775	101		
60	4.1	1050	28.2	1375	36.9	1250	33.6	3775	101		
80	5.5	1350	36.2	1375	36.9	1250	33.6				
100	6.9	1350	36.2	1375	36.9	1250	33.6				
125	8.6	1350	36.2	1250	33.6	1250	33.6				
psig	bar	Body Size: NPS 1-1/4									
0.5	34 mbar	60	1.6	100	2.6	160	4.2	240	6.4	300	8.1
1	69 mbar	100	2.7	170	4.5	250	6.7	400	10.7	425	11.4
2	138 mbar	130	3.5	250	6.7	400	10.7	575	15.4	775	20.8
3	0.21	160	4.3	270	7.2	475	12.8	775	20.8	1050	28.2
5	0.34	220	5.9	425	11.4	700	18.8	1175	31.5	1475	39.6
10	0.69	300	8.1	700	18.8	1150	30.9	2150	57.7	2450	65.8
15	1.0	375	10.1	870	23.4	1600	43.0	3000	80.5	3300	88.6
20	1.4	500	13.4	1050	28.2	1900	51.0	3200	85.9	2750	73.8
30	2.1	625	16.8	1320	35.4	2550	68.5	2200	59.1	2000	53.7
40	2.8	775	20.8	1725	46.3	2800	75.2	1825	49.0	1700	45.6
50	3.4	950	25.5	2025	54.4	2350	63.1	1600	42.9		
60	4.1	1075	28.9	2375	63.8	1900	51.0	1600	42.9		
80	5.5	1375	36.9	2875	77.2	1900	51.0				
100	6.9	1700	45.6	3150	84.6	1900	51.0				
125	8.6	1700	53.0	3175	85.2	1900	51.0				

Blank areas indicate where maximum operating inlet pressure for a given orifice size is exceeded.  
 Gray areas indicate limited capacities due to boost effects.

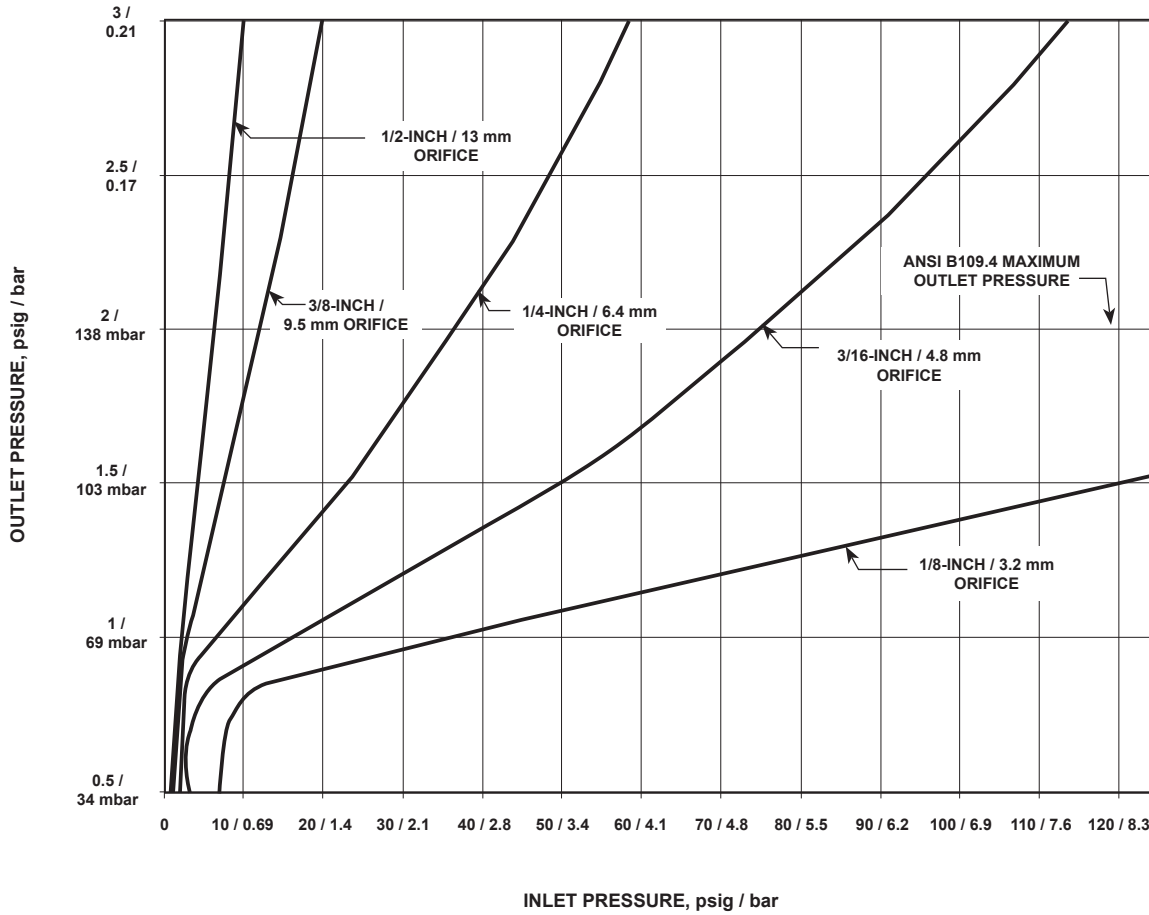

Figure 5. NPS 1 Body Type CS200IR Typical Relief Performance (Linkage Disconnect) at 7 inches w.c. / 17 mbar Set Pressure

Table 8. Type CS200IR Internal Relief Performance Table for 7 inches w.c. / 17 mbar Setpoint

ORIFICE SIZE		REGULATOR SET PRESSURE		MAXIMUM INLET PRESSURE TO KEEP OUTLET PRESSURE AT OR BELOW <sup>(1)(2)</sup>			
				1 psig / 69 mbar		2 psig / 138 mbar	
Inch	mm	Inch w.c.	mbar	psig	bar	psig	bar
1/8	3.2	7	17	36	2.5	>125	>8.6
3/16	4.8			15	1.0	74	5.1
1/4	6.4			6	0.41	36	2.5
3/8	9.5			3	0.21	12	0.83

1. Relief value obtained by disconnecting the lever.  
 2. 2 psig / 138 mbar is the maximum outlet pressure allowed per ANSI B109.4.

# Bulletin 71.1:CS200

**Table 9. CS200IN and CS200IR Series Flow Capacities for 11 inches w.c. / 27 mbar Setpoint**

ACCURACY				
SETPPOINT	Drop	Boost	SET RANGE	SPRING PART NUMBER / COLOR
11 inches w.c.	-2 inches w.c.	2 inches w.c.	7.5 to 11 inches w.c.	GE30189X012 / Blue
27 mbar	-5 mbar	5 mbar	19 to 27 mbar	

CAPACITIES IN SCFH / Nm <sup>3</sup> /h OF 0.6 SPECIFIC GRAVITY NATURAL GAS											
Inlet Pressure		Orifice Size, Inch / mm									
		1/8 / 3.2		3/16 / 4.8		1/4 / 6.4		3/8 / 9.5		1/2 / 13	
		SCFH	Nm <sup>3</sup> /h	SCFH	Nm <sup>3</sup> /h	SCFH	Nm <sup>3</sup> /h	SCFH	Nm <sup>3</sup> /h	SCFH	Nm <sup>3</sup> /h
psig	bar	Body Size: NPS 3/4									
1	69 mbar	85	2.3	185	5.0	300	8.1	425	11.4	575	15.4
2	138 mbar	130	3.5	285	7.7	425	11.4	600	16.1	825	22.1
3	0.21	170	4.6	350	9.4	525	14.1	775	20.8	1050	28.2
5	0.34	225	6.0	480	12.9	775	20.8	1150	30.9	1300	34.9
10	0.69	325	8.7	700	18.8	1200	32.2	1550	41.6	1625	43.6
15	1.0	400	10.7	900	24.2	1500	40.3	1850	49.7	1775	47.7
20	1.4	480	12.9	1075	28.9	1750	47.0	2025	54.4	2200	59.1
30	2.1	625	16.8	1400	37.6	2125	57.0	2200	59.1	2200	59.1
40	2.8	775	20.8	1700	45.6	2300	61.7	2200	59.1	2200	59.1
50	3.4	925	24.8	2025	54.4	2375	63.8	2200	59.1		
60	4.1	1050	28.2	2350	63.1	2450	65.8	2200	59.1		
80	5.5	1350	36.2	2500	67.1	2500	67.1				
100	6.9	1650	44.3	2500	67.1	2500	67.1				
125	8.6	1950	52.3	2500	67.1	2500	67.1				
psig	bar	Body Size: NPS 1									
1	69 mbar	85	2.3	185	5.0	300	8.1	500	13.4	650	17.4
2	138 mbar	130	3.5	285	7.7	425	11.4	725	19.5	975	26.2
3	0.21	170	4.6	350	9.4	525	14.1	925	24.8	1250	33.6
5	0.34	225	6.0	480	12.9	775	20.8	1325	35.6	1750	47.0
10	0.69	325	8.7	700	18.8	1250	33.6	1950	52.3	2400	64.4
15	1.0	400	10.7	900	24.2	1625	43.6	2500	67.1	2850	76.5
20	1.4	480	12.9	1075	28.9	1950	52.3	2925	78.5	2900	77.9
30	2.1	625	16.8	1400	37.6	2550	68.5	3550	95.3		
40	2.8	775	20.8	1725	46.3	3125	83.9	3900	105		
50	3.4	925	24.8	2050	55.0	1475	39.6	3900	105		
60	4.1	1050	28.2	1350	36.2	1475	39.6				
80	5.5	1350	36.2	1350	36.2	1475	39.6				
100	6.9	1475	39.6	1350	36.2						
125	8.6	1600	43.0								
psig	bar	Body Size: NPS 1-1/4									
1	69 mbar	85	2.3	170	4.6	300	8.1	500	13.4	650	17.4
2	138 mbar	130	3.5	270	7.2	425	11.4	725	19.5	1100	29.5
3	0.21	170	4.6	350	9.4	525	14.1	1000	26.8	1475	39.6
5	0.34	225	6.0	480	12.9	775	20.8	1375	36.9	2000	53.7
10	0.69	325	8.7	700	18.8	1250	33.6	2225	59.7	2450	65.8
15	1.0	400	10.7	900	24.2	1625	43.6	2850	76.5	2875	77.2
20	1.4	480	12.9	1075	28.9	1950	52.3	3400	91.3	3525	94.5
30	2.1	625	16.8	1400	37.6	2500	67.1	3400	91.3	1800	48.3
40	2.8	775	20.8	1725	46.3	2500	67.1	2400	64.4	1800	48.3
50	3.4	925	24.8	2050	55.0	2500	67.1	1700	45.6		
60	4.1	1050	28.2	2350	63.1	2500	67.1	1700	45.6		
80	5.5	1350	36.2	2975	79.9	2000	53.6				
100	6.9	1650	44.3	1700	45.6	1900	51.0				
125	8.6	2000	53.7	1700	45.6	1900	51.0				

Blank areas indicate where maximum operating inlet pressure for a given orifice size is exceeded.  
 Gray areas indicate limited capacities due to boost effects.

**Table 10. CS200IN and CS200IR Series Flow Capacities for 14 inches w.c. / 35 mbar Setpoint**

SETPOINT	ACCURACY		SET RANGE	SPRING PART NUMBER / COLOR
	Droop	Boost		
14 inches w.c.	-2 inches w.c.	2 inches w.c.	10 to 14 inches w.c.	GE30224X012 / Unpainted
35 mbar	-5 mbar	5 mbar	25 to 35 mbar	

CAPACITIES IN SCFH / Nm <sup>3</sup> /h OF 0.6 SPECIFIC GRAVITY NATURAL GAS											
Inlet Pressure		Orifice Size, Inch / mm									
		1/8 / 3.2		3/16 / 4.8		1/4 / 6.4		3/8 / 9.5		1/2 / 13	
		SCFH	Nm <sup>3</sup> /h	SCFH	Nm <sup>3</sup> /h	SCFH	Nm <sup>3</sup> /h	SCFH	Nm <sup>3</sup> /h	SCFH	Nm <sup>3</sup> /h
psig	bar	Body Size: NPS 3/4									
1	69 mbar	85	2.3	185	5.0	300	8.1	425	11.4	575	15.4
2	138 mbar	130	3.5	285	7.7	425	11.4	600	16.1	825	22.1
3	0.21	170	4.6	350	9.4	525	14.1	775	20.8	1050	28.2
5	0.34	225	6.0	480	12.9	775	20.8	1150	30.9	1300	34.9
10	0.69	325	8.7	700	18.8	1200	32.2	1550	41.6	1625	43.6
15	1.0	400	10.7	900	24.2	1500	40.3	1850	49.7	1775	47.7
20	1.4	480	12.9	1075	28.9	1750	47.0	2025	54.4	2200	59.1
30	2.1	625	16.8	1400	37.6	2125	57.0	2200	59.1		
40	2.8	775	20.8	1700	45.6	2300	61.7	2200	59.1		
50	3.4	925	24.8	2025	54.4	2375	63.8	2200	59.1		
60	4.1	1050	28.2	2350	63.1	2450	65.8				
80	5.5	1350	36.2	2500	67.1	2500	67.1				
100	6.9	1650	44.3	2500	67.1						
125	8.6	1950	52.3								
psig	bar	Body Size: NPS 1									
1	69 mbar	85	2.3	185	5.0	300	8.1	500	13.4	650	17.4
2	138 mbar	130	3.5	285	7.7	425	11.4	725	19.5	975	26.2
3	0.21	170	4.6	350	9.4	525	14.1	925	24.8	1250	33.6
5	0.34	225	6.0	480	12.9	775	20.8	1325	35.6	1750	47.0
10	0.69	325	8.7	700	18.8	1250	33.6	1950	52.3	2400	64.4
15	1.0	400	10.7	900	24.2	1625	43.6	2500	67.1	2850	76.5
20	1.4	480	12.9	1075	28.9	1950	52.3	2925	78.5	2900	77.9
30	2.1	625	16.8	1400	37.6	2550	68.5	3550	95.3	3400	91.3
40	2.8	775	20.8	1725	46.3	3125	83.9	3900	105		
50	3.4	925	24.8	2050	55.0	1475	39.6	3900	105		
60	4.1	1050	28.2	1350	36.2	1475	39.6				
80	5.5	1350	36.2	1350	36.2	1475	39.6				
100	6.9	1475	39.6	1350	36.2						
125	8.6	1600	43.0								
psig	bar	Body Size: NPS 1-1/4									
1	69 mbar	85	2.3	185	5.0	280	7.5	500	13.4	650	17.4
2	138 mbar	130	3.5	245	6.6	425	11.4	725	19.5	1100	29.5
3	0.21	170	4.6	350	9.4	525	14.1	1000	26.8	1475	39.6
5	0.34	225	6.0	480	12.9	775	20.8	1375	36.9	2000	53.7
10	0.69	325	8.7	700	18.8	1250	33.6	2225	59.7	2450	65.8
15	1.0	400	10.7	900	24.2	1625	43.6	2850	76.5	2875	77.2
20	1.4	480	12.9	1075	28.9	1950	52.3	3400	91.1	3525	94.6
30	2.1	625	16.8	1400	37.6	2300	61.7	3400	91.1	1850	49.7
40	2.8	775	20.8	1725	46.3	2300	61.7	2300	61.7	1850	49.7
50	3.4	925	24.8	2050	55.0	2300	61.7	2150	57.7		
60	4.1	1050	28.2	2350	63.1	2300	61.7	2150	57.7		
80	5.5	1350	36.2	2975	79.9	2000	53.6				
100	6.9	1650	44.3	2975	79.9	1900	51.0				
125	8.6	2000	53.7	2975	79.9	1900	51.0				

Blank areas indicate where maximum operating inlet pressure for a given orifice size is exceeded.  
 Gray areas indicate limited capacities due to boost effects.

# Bulletin 71.1:CS200

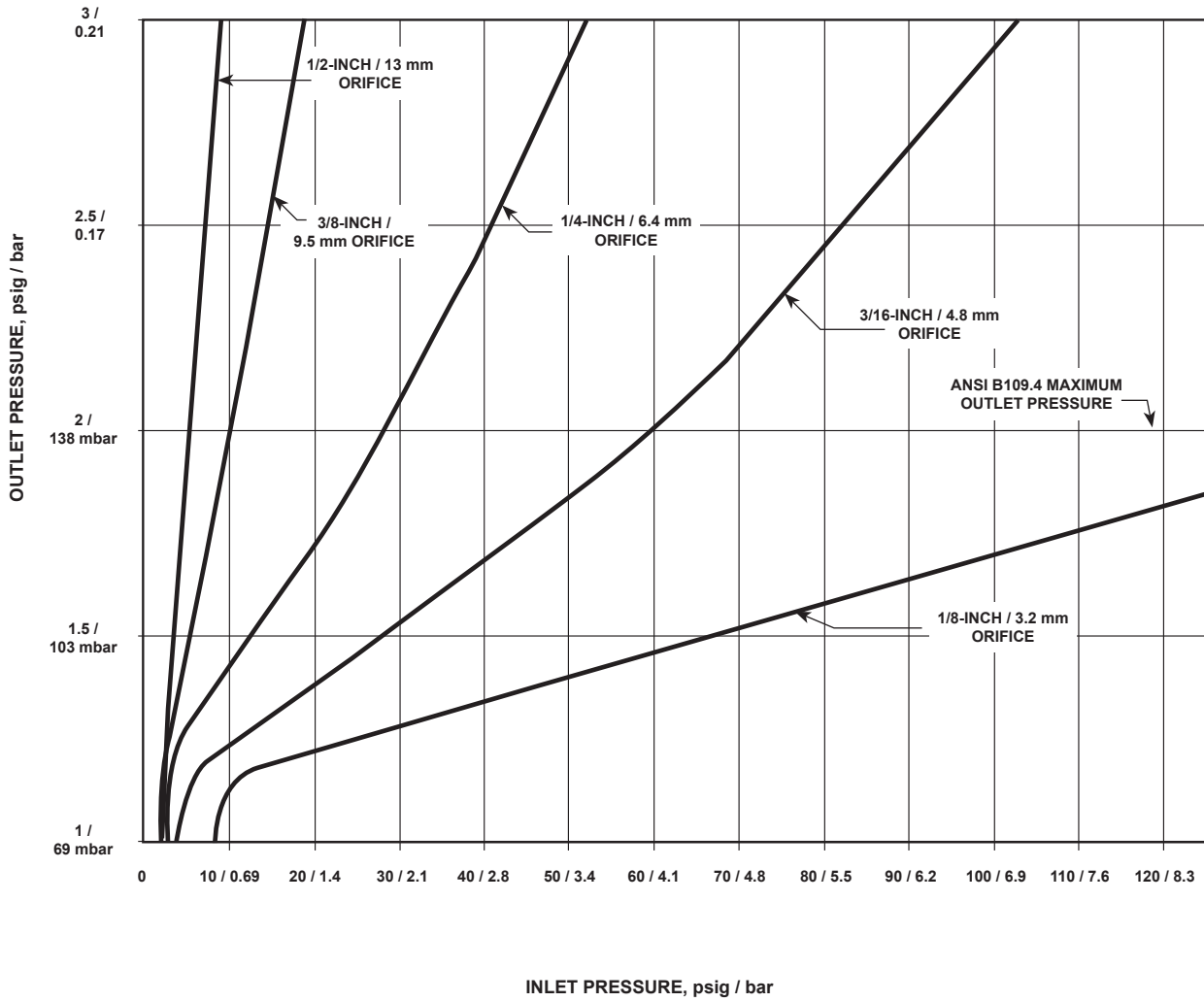

**Figure 6.** NPS 1 Body Type CS200IR Typical Relief Performance (Linkage Disconnect) at 14 inches w.c. / 35 mbar Set Pressure

**Table 11.** Type CS200IR Internal Relief Performance Table for 14-inches w.c. / 35 mbar Setpoint

ORIFICE SIZE		REGULATOR SET PRESSURE		MAXIMUM INLET PRESSURE TO KEEP OUTLET PRESSURE AT OR BELOW <sup>(1)(2)</sup>			
				2 psig / 138 mbar		2.5 psig / 0.17 bar	
Inch	mm	Inch w.c.	mbar	psig	bar	psig	bar
1/8	3.2	14	35	>125	>8.6	>125	>8.6
3/16	4.8			59	4.1	82	5.7
1/4	6.4			28	1.9	40	2.8
3/8	9.5			10	0.69	14	0.97

1. Relief value obtained by disconnecting the lever.  
 2. 2 psig / 138 mbar is the maximum outlet pressure allowed per ANSI B109.4.

**Table 12. CS200IN and CS200IR Series Flow Capacities for 1 psig / 69 mbar Setpoint at 1% Accuracy**

SETPPOINT	ACCURACY		SET RANGE	SPRING PART NUMBER / COLOR
	+ / - 1% ABS			
1 psig	-0.16 psi	0.16 psi	18 inches w.c. to 1 psig	GE30225X012 / Orange
69 mbar	-11 mbar	11 mbar	45 to 69 mbar	

CAPACITIES IN SCFH / Nm <sup>3</sup> /h OF 0.6 SPECIFIC GRAVITY NATURAL GAS											
Inlet Pressure		Orifice Size, Inch / mm									
		1/8 / 3.2		3/16 / 4.8		1/4 / 6.4		3/8 / 9.5		1/2 / 13	
		SCFH	Nm <sup>3</sup> /h	SCFH	Nm <sup>3</sup> /h	SCFH	Nm <sup>3</sup> /h	SCFH	Nm <sup>3</sup> /h	SCFH	Nm <sup>3</sup> /h
psig	bar	Body Size: NPS 3/4									
2	138 mbar	115	3.1	240	6.4	375	10.1	625	16.8	875	23.5
3	0.21	150	4.0	325	8.7	500	13.4	800	21.5	1175	31.5
5	0.34	225	6.0	450	12.1	725	19.5	1200	32.2	1475	39.6
10	0.69	325	8.7	725	19.5	1150	30.9	1750	47.0	1950	52.3
15	1.0	400	10.7	850	22.8	1500	40.3	2100	56.4	2225	59.7
20	1.4	475	12.8	1025	27.5	1725	46.3	2300	61.7	2350	63.1
30	2.1	625	16.8	1400	37.6	2175	58.4	2675	71.8	2700	72.5
40	2.8	750	20.1	1700	45.6	2550	68.5	2675	71.8	2700	72.5
50	3.4	900	24.2	2000	53.7	2650	71.1	2675	71.8		
60	4.1	1050	28.2	2350	63.1	2750	73.8	2675	71.8		
80	5.5	1350	36.2	2850	76.5	2850	76.5				
100	6.9	1600	43.0	2850	76.5	2850	76.5				
125	8.6	1975	53.0	2850	76.5						
psig	bar	Body Size: NPS 1									
2	138 mbar	115	3.1	240	6.4	400	10.7	675	18.1	950	25.5
3	0.21	150	4.0	325	8.7	550	14.8	975	26.2	1325	35.6
5	0.34	225	6.0	450	12.1	775	20.8	1400	37.6	1850	49.7
10	0.69	325	8.7	725	19.5	1200	32.2	2100	56.4	2600	69.8
15	1.0	400	10.7	850	22.8	1600	43.0	2750	73.8	3100	83.2
20	1.4	475	12.8	1025	27.5	1900	51.0	3200	85.9	3450	92.6
30	2.1	625	16.8	1400	37.6	2425	65.1	3750	101	4000	107
40	2.8	750	20.1	1700	45.6	3150	84.6	4375	117	4000	107
50	3.4	900	24.2	2000	53.7	3700	99.3	4550	122		
60	4.1	1050	28.2	2350	63.1	4150	111	4550	122		
80	5.5	1350	36.2	2975	79.9	4150	111				
100	6.9	1600	43.0	3650	98.0	4150	111				
125	8.6	1975	53.0	4400	118	4150	111				
psig	bar	Body Size: NPS 1-1/4									
2	138 mbar	115	3.1	240	6.4	425	11.4	750	20.1	1000	26.8
3	0.21	150	4.0	325	8.7	575	15.4	1050	28.2	1450	38.9
5	0.34	225	6.0	450	12.1	825	22.1	1500	40.2	2100	56.4
10	0.69	325	8.7	725	19.5	1300	34.9	2475	66.4	3250	87.2
15	1.0	400	10.7	850	22.8	1600	42.9	3325	89.3	4100	110
20	1.4	475	12.8	1025	27.5	1925	51.7	4095	110	4900	131
30	2.1	625	16.8	1400	37.6	2500	67.1	4400	118	4900	131
40	2.8	750	20.1	1700	45.6	3025	81.2	4400	118	4900	131
50	3.4	900	24.2	2000	53.7	3175	85.2	4400	118		
60	4.1	1050	28.2	2350	63.1	4275	115	4400	118		
80	5.5	1350	36.2	2975	79.9	4600	123				
100	6.9	1600	43.0	3650	98.0	4600	123				
125	8.6	1975	53.0	4400	118	4600	123				

Blank areas indicate where maximum operating inlet pressure for a given orifice size is exceeded.



# Bulletin 71.1:CS200

**Table 13. CS200IN and CS200IR Series Flow Capacities for 1 psig / 69 mbar bar Setpoint at 2% Accuracy**

SETPOINT	ACCURACY		SET RANGE	SPRING PART NUMBER / COLOR
	+ / - 2% ABS			
1 psig	-0.31 psi	0.31 psi	18 inches w.c. to 1 psig	GE30225X012 / Orange
69 mbar	-21 mbar	21 mbar	45 to 69 mbar	

CAPACITIES IN SCFH / Nm <sup>3</sup> /h OF 0.6 SPECIFIC GRAVITY NATURAL GAS											
Inlet Pressure		Orifice Size, Inch / mm									
		1/8 / 3.2		3/16 / 4.8		1/4 / 6.4		3/8 / 9.5		1/2 / 13	
		SCFH	Nm <sup>3</sup> /h	SCFH	Nm <sup>3</sup> /h	SCFH	Nm <sup>3</sup> /h	SCFH	Nm <sup>3</sup> /h	SCFH	Nm <sup>3</sup> /h
psig	bar	Body Size: NPS 3/4									
2	138 mbar	115	3.1	275	7.4	450	12.1	875	23.5	1300	34.9
3	0.21	150	4.0	350	9.4	600	16.1	1150	30.9	1675	45.0
5	0.34	225	6.0	500	13.4	850	22.8	1625	43.6	2150	57.7
10	0.69	325	8.7	775	20.8	1300	34.9	2425	65.1	2550	68.5
15	1.0	400	10.7	925	24.8	1650	44.3	2775	74.5	2875	77.2
20	1.4	475	12.8	1050	28.2	1925	51.7	3000	80.5	2975	79.9
30	2.1	625	16.8	1425	38.3	2500	67.1	3325	89.3	3400	91.3
40	2.8	750	20.1	1725	46.3	3025	81.2	3500	94.0	3500	94.0
50	3.4	900	24.2	2050	55.0	3425	91.9	3500	94.0		
60	4.1	1050	28.2	2375	63.8	3500	94.0	3500	94.0		
80	5.5	1350	36.2	3000	80.5	3500	94.0				
100	6.9	1600	43.0	3600	96.6	3500	94.0				
125	8.6	1975	53.0	3700	99.3						
psig	bar	Body Size: NPS 1									
2	138 mbar	115	3.1	275	7.4	450	12.1	950	25.5	1450	38.9
3	0.21	150	4.0	350	9.4	600	16.1	1275	34.2	1850	49.7
5	0.34	225	6.0	500	13.4	850	22.8	1775	47.7	2525	67.8
10	0.69	325	8.7	775	20.8	1300	34.9	2700	72.5	3400	91.3
15	1.0	400	10.7	925	24.8	1650	44.3	3425	91.9	4025	108
20	1.4	475	12.8	1050	28.2	1925	51.7	4000	107	4450	120
30	2.1	625	16.8	1425	38.3	2500	67.1	4800	129	4875	131
40	2.8	750	20.1	1725	46.3	3100	83.2	5450	146	5425	146
50	3.4	900	24.2	2050	55.0	3675	98.7	5950	160		
60	4.1	1050	28.2	2375	63.8	4275	115	6000	161		
80	5.5	1350	36.2	3000	80.5	5425	146				
100	6.9	1600	43.0	3600	96.6	5825	156				
125	8.6	1975	53.0	4400	118	5825	156				
psig	bar	Body Size: NPS 1-1/4									
2	138 mbar	115	3.1	275	7.4	450	12.1	1000	26.8	1450	38.9
3	0.21	150	4.0	350	9.4	600	16.1	1325	35.6	1950	52.3
5	0.34	225	6.0	500	13.4	850	22.8	1875	50.3	2800	75.2
10	0.69	325	8.7	775	20.8	1300	34.9	2825	75.8	4250	114
15	1.0	400	10.7	925	24.8	1650	44.3	3600	96.6	5250	141
20	1.4	475	12.8	1050	28.2	1925	51.7	4200	113	6200	166
30	2.1	625	16.8	1425	38.3	2500	67.1	5625	151	7400	199
40	2.8	750	20.1	1725	46.3	3100	83.2	6825	183	7600	204
50	3.4	900	24.2	2050	55.0	3675	98.7	7000	188		
60	4.1	1050	28.2	2375	63.8	4275	115	7000	188		
80	5.5	1350	36.2	3000	80.5	5425	146				
100	6.9	1600	43.0	3600	96.6	5825	156				
125	8.6	1975	53.0	4400	118	5825	156				

Blank areas indicate where maximum operating inlet pressure for a given orifice size is exceeded.

**Table 14. CS200IN and CS200IR Series Flow Capacities for 1 psig / 69 mbar Setpoint at 10% Accuracy**

SETPOINT	ACCURACY		SET RANGE	SPRING PART NUMBER / COLOR
	+ / - 10%			
1 psig	-0.1 psi	0.1 psi	18 inches w.c. to 1 psig	GE30225X012 / Orange
69 mbar	-7 mbar	7 mbar	45 to 69 mbar	

CAPACITIES IN SCFH / Nm <sup>3</sup> /h OF 0.6 SPECIFIC GRAVITY NATURAL GAS											
Inlet Pressure		Orifice Size, Inch / mm									
		1/8 / 3.2		3/16 / 4.8		1/4 / 6.4		3/8 / 9.5		1/2 / 13	
		SCFH	Nm <sup>3</sup> /h	SCFH	Nm <sup>3</sup> /h	SCFH	Nm <sup>3</sup> /h	SCFH	Nm <sup>3</sup> /h	SCFH	Nm <sup>3</sup> /h
psig	bar	Body Size: NPS 3/4									
2	138 mbar	115	3.1	225	6.0	300	8.1	475	12.8	650	17.4
3	0.21	150	4.0	300	8.1	425	11.4	625	16.8	925	24.8
5	0.34	225	6.0	400	10.7	600	16.1	875	23.5	1250	33.6
10	0.69	325	8.7	700	18.8	1000	26.8	1400	37.6	1675	45.0
15	1.0	400	10.7	825	22.1	1325	35.6	1750	47.0	1900	51.0
20	1.4	475	12.8	975	26.2	1575	42.3	1900	51.0	2125	57.0
30	2.1	625	16.8	1325	35.6	1950	52.3	2250	60.4	2300	61.7
40	2.8	750	20.1	1650	44.3	2200	59.1	2250	60.4	2300	61.7
50	3.4	900	24.2	1900	51.0	2375	63.8	2250	60.4		
60	4.1	1050	28.2	2300	61.7	2500	67.1	2250	60.4		
80	5.5	1350	36.2	2600	69.8	2500	67.1				
100	6.9	1600	43.0	2600	69.8	2500	67.1				
125	8.6	1975	53.0	2600	69.8						
psig	bar	Body Size: NPS 1									
2	138 mbar	115	3.1	225	6.0	350	9.4	500	13.4	650	17.4
3	0.21	150	4.0	325	8.7	450	12.1	675	18.1	900	24.2
5	0.34	225	6.0	450	12.1	675	18.1	1050	28.2	1450	38.9
10	0.69	325	8.7	725	19.5	1075	28.9	1675	45.0	2125	57.0
15	1.0	400	10.7	850	22.8	1475	39.6	2200	59.1	2650	71.1
20	1.4	475	12.8	1025	27.5	1800	48.3	2625	70.5	2850	76.5
30	2.1	625	16.8	1400	37.6	2350	63.1	3250	87.2	3500	94.0
40	2.8	750	20.1	1700	45.6	2950	79.2	3775	101	3650	98.0
50	3.4	900	24.2	2000	53.7	3450	92.6	4100	110		
60	4.1	1050	28.2	2350	63.1	3875	104	4100	110		
80	5.5	1350	36.2	2975	79.9	3875	104				
100	6.9	1600	43.0	3650	98.0	3875	104				
125	8.6	1975	53.0	4400	118	3875	104				
psig	bar	Body Size: NPS 1-1/4									
2	138 mbar	115	3.1	225	6.0	325	8.7	525	14.1	750	20.1
3	0.21	150	4.0	300	8.1	475	12.8	750	20.1	1075	28.9
5	0.34	225	6.0	425	11.4	675	18.1	1225	32.9	1475	39.6
10	0.69	325	8.7	600	16.1	1125	30.2	2000	53.7	2500	67.1
15	1.0	400	10.7	850	22.8	1500	40.3	2950	79.2	3550	95.3
20	1.4	475	12.8	1000	26.8	1875	50.3	3800	102	3900	105
30	2.1	625	16.8	1400	37.6	2500	67.1	3800	102	3900	105
40	2.8	750	20.1	1700	45.6	3025	81.2	3800	102	3900	105
50	3.4	900	24.2	2000	53.7	3175	85.2	4300	115		
60	4.1	1050	28.2	2300	61.7	3800	102	4300	115		
80	5.5	1350	36.2	2975	79.8	3800	102				
100	6.9	1600	43.0	3600	96.6	3800	102				
125	8.6	1975	53.0	3800	102	3800	102				

Blank areas indicate where maximum operating inlet pressure for a given orifice size is exceeded.

# Bulletin 71.1:CS200

**Table 15. CS200IN and CS200IR Series Flow Capacities for 1 psig / 69 mbar Setpoint at 20% Accuracy**

SETPOINT	ACCURACY		SET RANGE	SPRING PART NUMBER / COLOR
	+ / - 20%			
1 psig	-0.2 psi	0.2 psi	18 inches w.c. to 1 psig	GE30225X012 / Orange
69 mbar	-14 mbar	14 mbar	45 to 69 mbar	

CAPACITIES IN SCFH / Nm <sup>3</sup> /h OF 0.6 SPECIFIC GRAVITY NATURAL GAS											
Inlet Pressure		Orifice Size, Inch / mm									
		1/8 / 3.2		3/16 / 4.8		1/4 / 6.4		3/8 / 9.5		1/2 / 13	
		SCFH	Nm <sup>3</sup> /h	SCFH	Nm <sup>3</sup> /h	SCFH	Nm <sup>3</sup> /h	SCFH	Nm <sup>3</sup> /h	SCFH	Nm <sup>3</sup> /h
psig	bar	Body Size: NPS 3/4									
2	138 mbar	115	3.1	250	6.7	400	10.7	700	18.8	1025	27.5
3	0.21	150	4.0	325	8.7	525	14.1	925	24.8	1325	35.6
5	0.34	225	6.0	475	12.8	750	20.1	1325	35.6	1675	45.0
10	0.69	325	8.7	750	20.1	1200	32.2	1875	50.3	2100	56.4
15	1.0	400	10.7	875	23.5	1550	41.6	2250	60.4	2450	65.8
20	1.4	475	12.8	1025	27.5	1775	47.7	2550	68.5	2675	71.8
30	2.1	625	16.8	1400	37.6	2250	60.4	2800	75.2	2950	79.2
40	2.8	750	20.1	1700	45.6	2675	71.8	2800	75.2	2950	79.2
50	3.4	900	24.2	2025	54.4	2900	77.9	2800	75.2		
60	4.1	1050	28.2	2350	63.1	3250	87.2	2800	75.2		
80	5.5	1350	36.2	2950	79.2	3250	87.2				
100	6.9	1600	43.0	3200	85.9	3250	87.2				
125	8.6	1975	53.0	3200	85.9						
psig	bar	Body Size: NPS 1									
2	138 mbar	115	3.1	250	6.7	425	11.4	825	22.1	1050	28.2
3	0.21	150	4.0	325	8.7	575	15.4	1100	29.5	1500	40.3
5	0.34	225	6.0	475	12.8	800	21.5	1575	42.3	2025	54.4
10	0.69	325	8.7	750	20.1	1225	32.9	2325	62.4	2825	75.8
15	1.0	400	10.7	875	23.5	1625	43.6	2975	79.9	3400	91.3
20	1.4	475	12.8	1025	27.5	1900	51.0	3400	91.3	3750	101
30	2.1	625	16.8	1400	37.6	2450	65.8	3975	107	4300	115
40	2.8	750	20.1	1700	45.6	3100	83.2	4800	129	4300	115
50	3.4	900	24.2	2025	54.4	3675	98.7	4750	128		
60	4.1	1050	28.2	2350	63.1	4200	113	4750	128		
80	5.5	1350	36.2	2975	79.9	5250	141				
100	6.9	1600	43.0	3600	96.6	5400	145				
125	8.6	1975	53.0	4400	118	4550	122				
psig	bar	Body Size: NPS 1-1/4									
2	138 mbar	115	3.1	250	6.7	425	11.4	850	22.8	1175	31.5
3	0.21	150	4.0	325	8.7	575	15.4	1175	31.5	1675	45.0
5	0.34	225	6.0	475	12.8	825	22.1	1675	45.0	2375	63.8
10	0.69	325	8.7	750	20.1	1300	34.9	2600	69.8	3600	96.6
15	1.0	400	10.7	875	23.5	1625	43.6	3475	93.3	4650	125
20	1.4	475	12.8	1025	27.5	1925	51.7	4125	111	5650	152
30	2.1	625	16.8	1400	37.6	2500	67.1	5575	150	6975	187
40	2.8	750	20.1	1700	45.6	3050	81.9	6675	179	7525	202
50	3.4	900	24.2	2025	54.4	3325	89.3	7600	204		
60	4.1	1050	28.2	2350	63.1	4275	115	7600	204		
80	5.5	1350	36.2	2975	79.9	5425	146				
100	6.9	1600	43.0	3600	96.6	5825	156				
125	8.6	1975	53.0	4400	118	5825	156				

Blank areas indicate where maximum operating inlet pressure for a given orifice size is exceeded.  
 Gray areas indicate limited capacities due to boost effects.

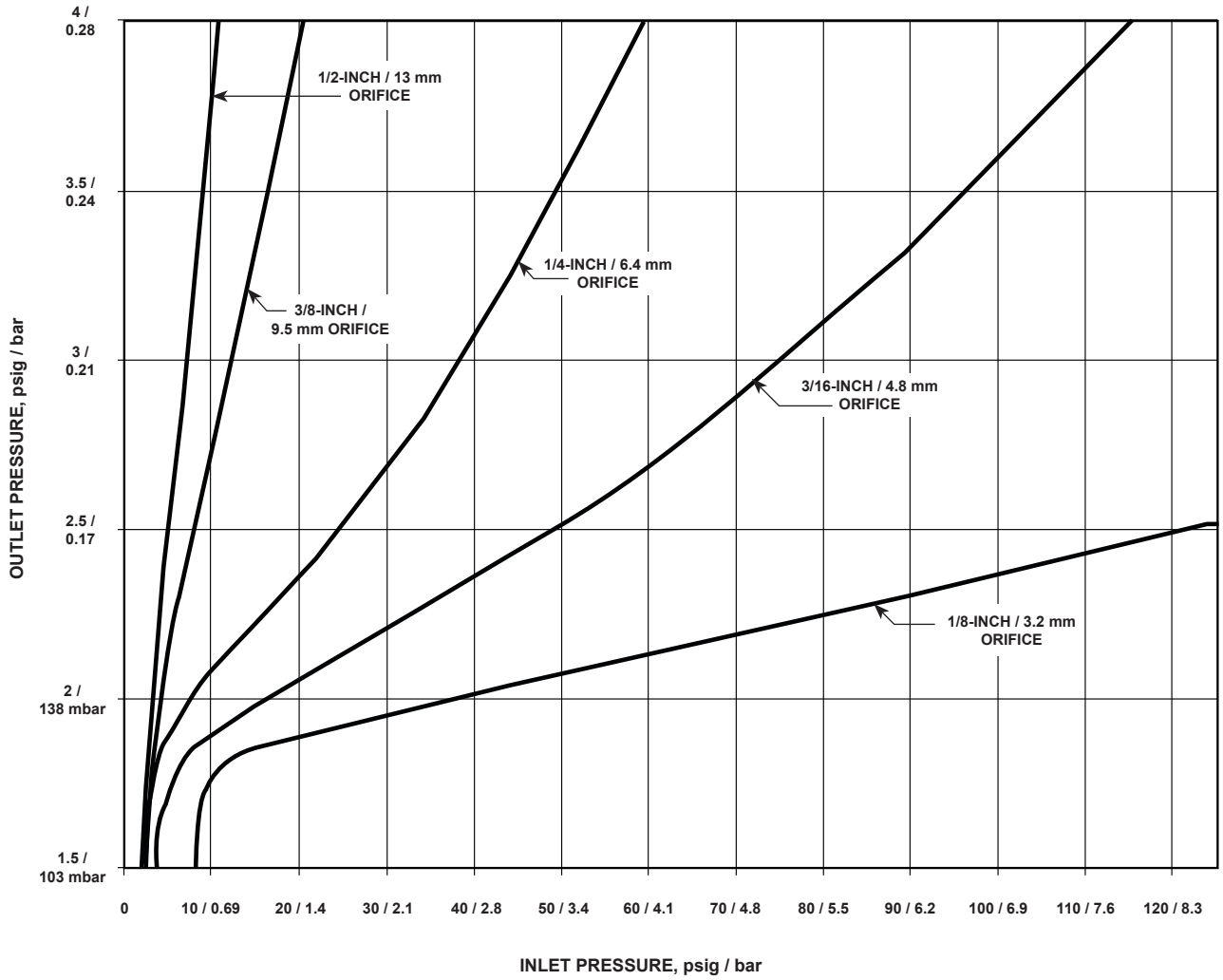

Figure 7. NPS 1 Body Type CS200IR Typical Relief Performance (Linkage Disconnect) at 1 psig / 69 mbar Set Pressure

Table 16. Type CS200IR Internal Relief Performance Table for 1 psig / 69 mbar Setpoint

ORIFICE SIZE		REGULATOR SET PRESSURE		MAXIMUM INLET PRESSURE TO KEEP OUTLET PRESSURE AT OR BELOW <sup>(1)</sup>			
				2.5 psig / 0.17 bar		3 psig / 0.21 bar	
Inch	mm	psig	mbar	psig	bar	psig	bar
1/8	3.2	1	69	121	8.3	>125	>8.6
3/16	4.8			49	3.4	74	5.1
1/4	6.4			24	1.7	38	2.6
3/8	9.5			8	0.55	12	0.83

1. Relief value obtained by disconnecting the lever.

# Bulletin 71.1:CS200

**Table 17. CS200IN and CS200IR Series Flow Capacities for 2 psig / 138 mbar Setpoint at 1% Accuracy**

SETPOINT	ACCURACY		SET RANGE	SPRING PART NUMBER / COLOR
	+ / - 1% ABS			
2 psig	-0.17 psi	0.17 psi	1 to 2 psig	GE30190X012 / Black
138 mbar	-12 mbar	12 mbar	69 to 138 mbar	

CAPACITIES IN SCFH / Nm <sup>3</sup> /h OF 0.6 SPECIFIC GRAVITY NATURAL GAS											
Inlet Pressure		Orifice Size, Inch / mm									
		1/8 / 3.2		3/16 / 4.8		1/4 / 6.4		3/8 / 9.5		1/2 / 13	
		SCFH	Nm <sup>3</sup> /h	SCFH	Nm <sup>3</sup> /h	SCFH	Nm <sup>3</sup> /h	SCFH	Nm <sup>3</sup> /h	SCFH	Nm <sup>3</sup> /h
psig	bar	Body Size: NPS 3/4									
3	0.21	120	3.2	250	6.7	250	6.7	425	11.4	550	14.8
5	0.34	150	4.0	350	9.4	445	11.9	700	18.8	1000	26.8
10	0.69	250	6.7	550	14.8	720	19.3	1125	30.2	1550	41.6
15	1.0	330	8.9	750	20.1	1100	29.5	1575	42.3	1900	51.0
20	1.4	425	11.4	950	25.5	1375	36.9	1800	48.3	2125	57.0
30	2.1	550	14.8	1300	34.9	1850	49.7	2150	57.7	2475	66.4
40	2.8	750	20.1	1425	38.3	2175	58.4	2450	65.8	2575	69.1
50	3.4	875	23.5	1900	51.0	2475	66.4	2575	69.1		
60	4.1	1025	27.5	2100	56.4	2600	69.8	2675	71.8		
80	5.5	1300	34.9	2475	66.4	2850	76.5				
100	6.9	1600	43.0	2725	73.2	2850	76.5				
125	8.6	1975	53.0	2850	76.5						
psig	bar	Body Size: NPS 1									
3	0.21	120	3.2	250	6.7	300	8.1	475	12.8	675	18.1
5	0.34	150	4.0	350	9.4	445	11.9	800	21.5	1000	26.8
10	0.69	250	6.7	550	14.8	720	19.3	1400	37.6	1850	49.7
15	1.0	330	8.9	800	21.5	1120	30.1	1900	51.0	2500	67.1
20	1.4	425	11.4	1000	26.8	1445	38.8	2325	62.4	2800	75.2
30	2.1	550	14.8	1350	36.2	2045	54.9	3000	80.5	3300	88.6
40	2.8	750	20.1	1600	43.0	2750	73.8	3500	94.0	4100	110
50	3.4	875	23.5	1950	52.3	3300	88.6	3900	105		
60	4.1	1025	27.5	2300	61.7	3825	103	4100	110		
80	5.5	1300	34.9	3000	80.5	4200	113				
100	6.9	1600	43.0	3550	95.3	4200	113				
125	8.6	1975	53.0	4200	113	4200	113				
psig	bar	Body Size: NPS 1-1/4									
3	0.21	120	3.2	250	6.7	290	7.7	475	12.8	675	18.1
5	0.34	150	4.0	350	9.4	445	11.9	825	22.1	1000	26.8
10	0.69	250	6.7	550	14.8	720	19.3	1500	40.3	1850	49.7
15	1.0	330	8.9	800	21.5	1120	30.1	2175	58.4	2800	75.2
20	1.4	425	11.4	1000	26.8	1495	40.1	2675	71.8	3675	98.7
30	2.1	550	14.8	1350	36.2	2220	59.6	3950	106	5400	145
40	2.8	750	20.1	1600	43.0	3000	80.5	5400	145	5400	145
50	3.4	875	23.5	1950	52.3	3475	93.3	5400	145		
60	4.1	1025	27.5	2300	61.7	4075	109	5400	145		
80	5.5	1300	34.9	3000	80.5	4400	118				
100	6.9	1600	43.0	3550	95.3	4400	118				
125	8.6	1975	53.0	4200	113	4400	118				

Blank areas indicate where maximum operating inlet pressure for a given orifice size is exceeded.

**Table 18. CS200IN and CS200IR Series Flow Capacities for 2 psig / 138 mbar Setpoint at 2% Accuracy**

SETPOINT	ACCURACY		SET RANGE	SPRING PART NUMBER / COLOR
	+ / - 2% ABS			
2 psig	-0.33 psi	0.33 psi	1 to 2 psig	GE30190X012 / Black
138 mbar	-23 mbar	23 mbar	69 to 138 mbar	

CAPACITIES IN SCFH / Nm <sup>3</sup> /h OF 0.6 SPECIFIC GRAVITY NATURAL GAS											
Inlet Pressure		Orifice Size, Inch / mm									
		1/8 / 3.2		3/16 / 4.8		1/4 / 6.4		3/8 / 9.5		1/2 / 13	
		SCFH	Nm <sup>3</sup> /h	SCFH	Nm <sup>3</sup> /h	SCFH	Nm <sup>3</sup> /h	SCFH	Nm <sup>3</sup> /h	SCFH	Nm <sup>3</sup> /h
psig	bar	Body Size: NPS 3/4									
3	0.21	120	3.2	275	7.4	450	12.1	700	18.8	1100	29.5
5	0.34	150	4.0	425	11.4	675	18.1	1050	28.2	1550	41.6
10	0.69	250	6.7	675	18.1	1150	30.9	1850	49.7	2225	59.7
15	1.0	330	8.9	875	23.5	1450	38.9	2175	58.4	2650	71.1
20	1.4	425	11.4	1050	28.2	1725	46.3	2500	67.1	2825	75.8
30	2.1	550	14.8	1400	37.6	2150	57.7	2975	79.9	3300	88.6
40	2.8	750	20.1	1650	44.3	2800	75.2	3275	87.9	3300	88.6
50	3.4	875	23.5	2050	55.0	3000	80.5	3400	91.3		
60	4.1	1025	27.5	2275	61.1	3300	88.6	3400	91.3		
80	5.5	1300	34.9	3000	80.5	3500	94.0				
100	6.9	1600	43.0	3400	91.3	3500	94.0				
125	8.6	1975	53.0	3400	91.3						
psig	bar	Body Size: NPS 1									
3	0.21	120	3.2	275	7.4	450	12.1	700	18.8	1100	29.5
5	0.34	150	4.0	425	11.4	675	18.1	1250	33.6	1725	46.3
10	0.69	250	6.7	675	18.1	1175	31.5	2075	55.7	2750	73.8
15	1.0	330	8.9	875	23.5	1550	41.6	2675	71.8	3425	91.9
20	1.4	425	11.4	1050	28.2	1900	51.0	3250	87.2	3900	105
30	2.1	550	14.8	1400	37.6	2500	67.1	4025	108	4475	120
40	2.8	750	20.1	1650	44.3	3050	81.9	4550	122	5100	137
50	3.4	875	23.5	2050	55.0	3650	98.0	5000	134		
60	4.1	1025	27.5	2275	61.1	4250	114	5200	140		
80	5.5	1300	34.9	3000	80.5	5450	146				
100	6.9	1600	43.0	3600	96.6	5700	153				
125	8.6	1975	53.0	4450	120	5700	153				
psig	bar	Body Size: NPS 1-1/4									
3	0.21	120	3.2	275	7.4	430	11.5	750	20.1	1150	30.9
5	0.34	150	4.0	425	11.4	675	18.1	1300	34.9	1700	45.6
10	0.69	250	6.7	675	18.1	1175	31.5	2225	59.7	3090	83.0
15	1.0	330	8.9	875	23.5	1550	41.6	2975	79.9	4090	110
20	1.4	425	11.4	1050	28.2	1900	51.0	3800	102	5025	135
30	2.1	550	14.8	1400	37.6	2500	67.1	5250	141	5900	158
40	2.8	750	20.1	1650	44.3	3050	81.9	5800	155	5900	158
50	3.4	875	23.5	2050	55.0	3650	98.0	5800	155		
60	4.1	1025	27.5	2275	61.1	4250	114	5800	155		
80	5.5	1300	34.9	3000	80.5	4900	131				
100	6.9	1600	43.0	3600	96.6	4900	131				
125	8.6	1975	53.0	4450	120	4900	131				

Blank areas indicate where maximum operating inlet pressure for a given orifice size is exceeded.

# Bulletin 71.1:CS200

**Table 19. CS200IN and CS200IR Series Flow Capacities for 2 psig / 138 mbar Setpoint at 10% Accuracy**

SETPOINT	ACCURACY		SET RANGE	SPRING PART NUMBER / COLOR
	+ / - 10%			
2 psig	-0.2 psi	0.2 psi	1 to 2 psig	GE30190X012 / Black
138 mbar	-14 mbar	14 mbar	69 to 138 mbar	

CAPACITIES IN SCFH / Nm <sup>3</sup> /h OF 0.6 SPECIFIC GRAVITY NATURAL GAS											
Inlet Pressure		Orifice Size, Inch / mm									
		1/8 / 3.2		3/16 / 4.8		1/4 / 6.4		3/8 / 9.5		1/2 / 13	
		SCFH	Nm <sup>3</sup> /h	SCFH	Nm <sup>3</sup> /h	SCFH	Nm <sup>3</sup> /h	SCFH	Nm <sup>3</sup> /h	SCFH	Nm <sup>3</sup> /h
psig	bar	Body Size: NPS 3/4									
3	0.21	120	3.2	250	6.7	250	6.7	425	11.4	550	14.8
5	0.34	150	4.0	350	9.4	445	11.9	700	18.8	1000	26.8
10	0.69	250	6.7	550	14.8	720	19.3	1125	30.2	1550	41.6
15	1.0	330	8.9	750	20.1	1100	29.5	1575	42.3	1900	51.0
20	1.4	425	11.4	950	25.5	1375	36.9	1800	48.3	2125	57.0
30	2.1	550	14.8	1300	34.9	1850	49.7	2150	57.7	2475	66.4
40	2.8	750	20.1	1425	38.3	2175	58.4	2450	65.8	2575	69.1
50	3.4	875	23.5	1900	51.0	2475	66.4	2575	69.1		
60	4.1	1025	27.5	2100	56.4	2600	69.8	2675	71.8		
80	5.5	1300	34.9	2475	66.4	2850	76.5				
100	6.9	1600	43.0	2725	73.2	2850	76.5				
125	8.6	1975	53.0	2850	76.5						
psig	bar	Body Size: NPS 1									
3	0.21	120	3.2	250	6.7	300	8.1	475	12.8	675	18.1
5	0.34	150	4.0	350	9.4	445	11.9	800	21.5	1000	26.8
10	0.69	250	6.7	550	14.8	720	19.3	1400	37.6	1850	49.7
15	1.0	330	8.9	800	21.5	1120	30.1	1900	51.0	2500	67.1
20	1.4	425	11.4	1000	26.8	1445	38.8	2325	62.4	2800	75.2
30	2.1	550	14.8	1350	36.2	2045	54.9	3000	80.5	3300	88.6
40	2.8	750	20.1	1600	43.0	2750	73.8	3500	94.0	4100	110
50	3.4	875	23.5	1950	52.3	3300	88.6	3900	105		
60	4.1	1025	27.5	2300	61.7	3825	103	4100	110		
80	5.5	1300	34.9	3000	80.5	4200	113				
100	6.9	1600	43.0	3550	95.3	4200	113				
125	8.6	1975	53.0	4200	113	4200	113				
psig	bar	Body Size: NPS 1-1/4									
3	0.21	120	3.2	250	6.7	300	8.1	475	12.8	675	18.1
5	0.34	150	4.0	350	9.4	445	11.9	825	22.1	1000	26.8
10	0.69	250	6.7	550	14.8	720	19.3	1525	40.9	1850	49.7
15	1.0	330	8.9	640	17.1	1120	30.1	2175	58.4	2800	75.2
20	1.4	425	11.4	1000	26.8	1495	40.1	2675	71.8	3675	98.7
30	2.1	550	14.8	1100	29.5	2220	59.6	3950	106	5475	147
40	2.8	750	20.1	1600	43.0	3000	80.5	5700	153	6600	177
50	3.4	875	23.5	1950	52.3	3475	93.3	5900	158		
60	4.1	1025	27.5	2300	61.7	4075	109	5900	158		
80	5.5	1300	34.9	3000	80.5	5300	142				
100	6.9	1600	43.0	3550	95.3	5300	142				
125	8.6	1975	53.0	4200	113	5300	142				

Blank areas indicate where maximum operating inlet pressure for a given orifice size is exceeded.



**Table 20. CS200IN and CS200IR Series Flow Capacities for 2 psig / 138 mbar Setpoint at 20% Accuracy**

SETPOINT	ACCURACY		SET RANGE	SPRING PART NUMBER / COLOR
	+ / - 20%			
2 psig	-0.4 psi	0.4 psi	1 to 2 psig	GE30190X012 / Black
138 mbar	-28 mbar	28 mbar	69 to 138 mbar	

CAPACITIES IN SCFH / Nm <sup>3</sup> /h OF 0.6 SPECIFIC GRAVITY NATURAL GAS											
Inlet Pressure		Orifice Size, Inch / mm									
		1/8 / 3.2		3/16 / 4.8		1/4 / 6.4		3/8 / 9.5		1/2 / 13	
		SCFH	Nm <sup>3</sup> /h	SCFH	Nm <sup>3</sup> /h	SCFH	Nm <sup>3</sup> /h	SCFH	Nm <sup>3</sup> /h	SCFH	Nm <sup>3</sup> /h
psig	bar	Body Size: NPS 3/4									
3	0.21	120	3.2	275	7.4	450	12.1	775	20.8	1250	33.6
5	0.34	150	4.0	425	11.4	675	18.1	1200	32.2	1825	49.0
10	0.69	250	6.7	675	18.1	1150	30.9	2025	54.4	2400	64.4
15	1.0	330	8.9	875	23.5	1450	38.9	2450	65.8	2825	75.8
20	1.4	425	11.4	1050	28.2	1725	46.3	2725	73.2	3050	81.9
30	2.1	550	14.8	1400	37.6	2150	57.7	3200	85.9	3600	96.6
40	2.8	750	20.1	1650	44.3	3000	80.5	3525	94.6	3600	96.6
50	3.4	875	23.5	2050	55.0	3225	86.6	3600	96.6		
60	4.1	1025	27.5	2275	61.1	3600	96.6	3600	96.6		
80	5.5	1300	34.9	3000	80.5	3600	96.6				
100	6.9	1600	43.0	3400	91.3	3600	96.6				
125	8.6	1975	53.0	3400	91.3						
psig	bar	Body Size: NPS 1									
3	0.21	120	3.2	275	7.4	450	12.1	925	24.8	1300	34.9
5	0.34	150	4.0	425	11.4	675	18.1	1400	37.6	2025	54.4
10	0.69	250	6.7	675	18.1	1175	31.5	2250	60.4	3050	81.9
15	1.0	330	8.9	875	23.5	1550	41.6	2950	79.2	3800	102
20	1.4	425	11.4	1050	28.2	1900	51.0	3525	94.6	4200	113
30	2.1	550	14.8	1400	37.6	2500	67.1	4375	117	4800	129
40	2.8	750	20.1	1650	44.3	3050	81.9	4950	133	5550	149
50	3.4	875	23.5	2050	55.0	3650	98.0	5500	148		
60	4.1	1025	27.5	2275	61.1	4250	114	5775	155		
80	5.5	1300	34.9	3000	80.5	5450	146				
100	6.9	1600	43.0	3600	96.6	6000	161				
125	8.6	1975	53.0	4450	120	6000	161				
psig	bar	Body Size: NPS 1-1/4									
3	0.21	120	3.2	275	7.4	450	12.1	825	22.1	1300	34.8
5	0.34	150	4.0	425	11.4	675	18.1	1450	38.9	1900	51.0
10	0.69	250	6.7	675	18.1	1175	31.5	2400	64.4	3400	91.1
15	1.0	330	8.9	875	23.5	1550	41.6	3200	85.9	4400	118
20	1.4	425	11.4	1050	28.2	1900	51.0	3850	104	5450	146
30	2.1	550	14.8	1400	37.6	2500	67.1	5250	141	6000	161
40	2.8	750	20.1	1650	44.3	3050	81.9	5800	155	6000	161
50	3.4	875	23.5	2050	55.0	3650	98.0	5800	155		
60	4.1	1025	27.5	2275	61.1	4250	114	5800	155		
80	5.5	1300	34.9	3000	80.5	5450	146				
100	6.9	1600	43.0	3600	96.6	5450	146				
125	8.6	1975	53.0	4450	120	5450	146				

Blank areas indicate where maximum operating inlet pressure for a given orifice size is exceeded.

# Bulletin 71.1:CS200

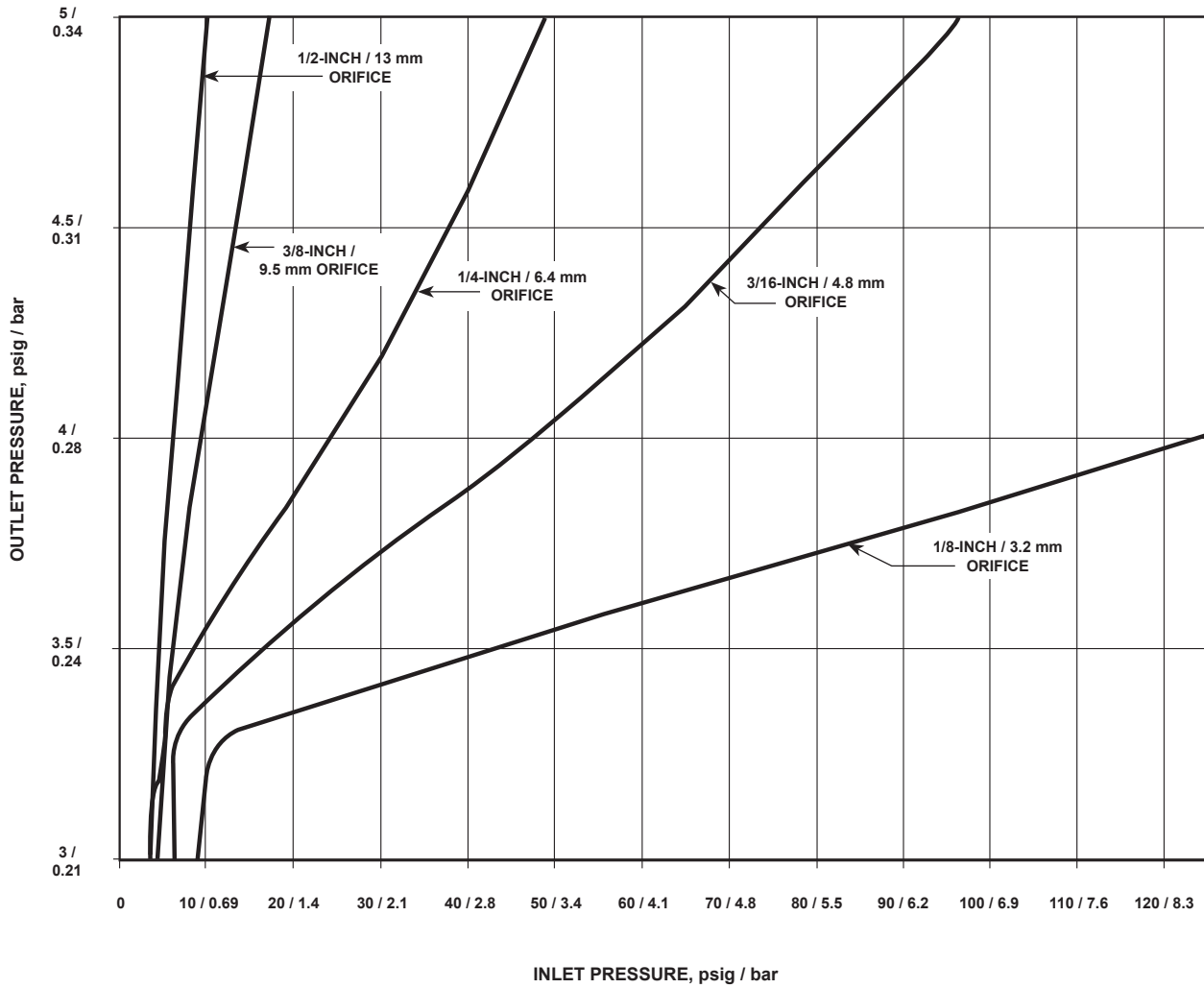

Figure 8. NPS 1 Body Type CS200IR Typical Relief Performance (Linkage Disconnect) at 2 psig / 138 mbar Set Pressure

Table 21. Type CS200IR Internal Relief Performance Table for 2 psig / 138 mbar Setpoint

ORIFICE SIZE		REGULATOR SET PRESSURE		MAXIMUM INLET PRESSURE TO KEEP OUTLET PRESSURE AT OR BELOW <sup>(1)</sup>			
				4 psig / 0.28 bar		5 psig / 0.34 bar	
Inch	mm	psig	mbar	psig	bar	psig	bar
1/8	3.2	2	138	122	8.4	>125	>8.6
3/16	4.8			47	3.2	96	6.6
1/4	6.4			23	1.6	49	3.4
3/8	9.5			9	0.62	17	1.17

1. Relief value obtained by disconnecting the lever.

**Table 22. CS205 and CS206 Series Flow Capacities for 7-inches w.c. / 17 mbar Setpoint**

SETPPOINT	ACCURACY		SET RANGE	SPRING PART NUMBER / COLOR
	Drop	Boost		
7 inches w.c. 17 mbar	-1 inch w.c. -2 mbar	2 inches w.c. 5 mbar	6 to 8 inches w.c. 15 to 20 mbar	GE30188X012 / Gold

CAPACITIES IN SCFH / Nm <sup>3</sup> /h OF 0.6 SPECIFIC GRAVITY NATURAL GAS									
Inlet Pressure		Orifice Size, Inch / mm							
		18 / 3.2		3/16 / 4.8		1/4 / 6.4		5/16 / 7.9	
		SCFH	Nm <sup>3</sup> /h	SCFH	Nm <sup>3</sup> /h	SCFH	Nm <sup>3</sup> /h	SCFH	Nm <sup>3</sup> /h
psig	bar	Body Size: NPS 3/4							
0.5	34 mbar					155	4.2	205	5.5
1	69 mbar			160	4.3	260	7.0	290	7.8
2	138 mbar	110	2.9	235	6.3	325	8.7	370	9.9
3	0.21	145	3.9	320	8.6	430	11.5	475	12.7
5	0.34	200	5.4	450	12.1	615	16.5	710	19.0
10	0.69	290	7.8	690	18.5	985	26.4	1060	28.4
15	1.0	400	10.7	950	25.5	1310	35.1	1380	37.0
20	1.4	510	13.7	1180	31.6	1560	41.8	1600	42.9
30	2.1	685	18.4	1570	42.1	1990	53.3	1900	50.9
40	2.8	855	22.9	1970	52.8	2300	61.6	2160	57.9
50	3.4	1030	27.6	2300	61.6	2570	68.9	2380	63.8
60	4.1	1220	32.7	2550	68.3	2700	72.3	2560	68.6
80	5.5	1550	41.5	2910	78.0	2970	79.6	2640	70.7
90	6.2	1740	46.6	3020	80.9	2950	79.0	2750	73.7
100	6.9	1880	50.4	2810	75.3	2890	77.4	2670	71.5
psig	bar	Body Size: NPS 1							
0.5	34 mbar					215	5.8	200	5.4
1	69 mbar					295	7.9	315	8.4
2	138 mbar			190	5.1	375	10.0	460	12.3
3	0.21			270	7.2	475	12.7	625	16.7
5	0.34	145	3.9	390	10.4	710	19.0	840	22.5
10	0.69	265	7.1	680	18.2	1150	30.8	1370	36.7
15	1.0	385	10.3	935	25.0	1620	43.4	1810	48.5
20	1.4	450	12.1	1160	31.1	2020	54.1	2210	59.2
30	2.1	630	16.9	1530	41.0	1410	37.8	2970	79.6
40	2.8	805	21.6	1910	51.2	1090	29.2	1200	32.1
50	3.4	975	26.1	1090	29.2	990	26.5	1000	26.8
60	4.1	1140	30.5	860	23.0	940	25.2	930	24.9
80	5.5	905	24.2	860	23.0	925	24.8	930	24.9
90	6.2	905	24.2	835	22.4	925	24.8	930	24.9
100	6.9	905	24.2	835	22.4	925	24.8	930	24.9
psig	bar	Body Size: NPS 1-1/4							
0.5	34 mbar			120	3.2	210	5.6	165	4.4
1	69 mbar			170	4.6	290	7.8	235	6.3
2	138 mbar			260	7.0	380	10.2	390	10.4
3	0.21			315	8.4	460	12.3	495	13.3
5	0.34	130	3.5	470	12.6	655	17.5	695	18.6
10	0.69	250	6.7	735	19.7	1180	31.6	1240	33.2
15	1.0	315	8.4	940	25.2	1560	41.8	1680	45.0
20	1.4	455	12.2	1160	31.1	1950	52.2	2100	56.3
30	2.1	630	16.9	1560	41.8	2630	70.5	2800	75.0
40	2.8	805	21.6	1860	49.8	1380	37.0	1340	35.9
50	3.4	965	25.9	1090	29.2	1260	33.8	1180	31.6
60	4.1	1140	30.5	1010	27.1	1110	29.7	1070	28.7
80	5.5	965	25.9	970	26.0	1110	29.7	1070	28.7
90	6.2	940	25.2	940	25.2	1110	29.7	1070	28.7
100	6.9	940	25.2	940	25.2	1110	29.7	1070	28.7

Black areas show where indicated droop/boost would be exceeded regardless of capacity.  
 Gray areas indicate limited capacities due to boost effects.

# Bulletin 71.1:CS200

**Table 23. CS205 and CS206 Series Flow Capacities for 7-inches w.c. / 17 mbar Setpoint**

SETPOINT	ACCURACY		SET RANGE	SPRING PART NUMBER / COLOR
	Droop	Boost		
11 inches w.c.	-2 inches w.c.	2 inches w.c.	7.5 to 11 inches w.c.	GE30189X012 / Blue
27 mbar	-5 mbar	5 mbar	19 to 27 mbar	

CAPACITIES IN SCFH / Nm³/h OF 0.6 SPECIFIC GRAVITY NATURAL GAS									
Inlet Pressure		Orifice Size, Inch / mm							
		18 / 3.2		3/16 / 4.8		1/4 / 6.4		5/16 / 7.9	
		SCFH	Nm³/h	SCFH	Nm³/h	SCFH	Nm³/h	SCFH	Nm³/h
psig	bar	Body Size: NPS 3/4							
1	69 mbar			155	4.2	320	8.6	315	8.4
2	138 mbar			270	7.2	385	10.3	480	12.9
3	0.21	145	3.9	360	9.6	545	14.6	635	17.0
5	0.34	200	5.4	480	12.9	720	19.3	850	22.8
10	0.69	325	8.7	745	20.0	1100	29.5	1160	31.1
15	1.0	415	11.1	990	26.5	1450	38.8	1490	39.9
20	1.4	510	13.7	1150	30.8	1710	45.8	1760	47.2
30	2.1	685	18.4	1530	41.0	2180	58.4	2090	56.0
40	2.8	850	22.8	1860	49.8	2390	64.0	2390	64.0
50	3.4	1020	27.3	2220	59.5	2760	73.9	2640	70.7
60	4.1	1200	32.1	2530	67.8	3000	80.4	2790	74.7
80	5.5	1550	41.5	3200	85.7	3160	84.7	2940	78.8
100	6.9	1740	46.6	3140	84.1	3160	84.7	3030	81.2
125	8.6	1910	51.2	3140	84.1	3160	84.7	3030	81.2
psig	bar	Body Size: NPS 1							
1	69 mbar					265	7.1	345	9.2
2	138 mbar			200	5.4	445	11.9	510	13.7
3	0.21	135	3.6	275	7.4	570	15.3	675	18.1
5	0.34	205	5.5	425	11.4	785	21.0	880	23.6
10	0.69	325	8.7	725	19.4	1270	34.0	1420	38.0
15	1.0	410	11.0	795	21.3	1670	44.7	1890	50.6
20	1.4	510	13.7	1130	30.3	1980	53.0	2300	61.6
30	2.1	675	18.1	1520	40.7	2660	71.3	2980	79.8
40	2.8	860	23.0	1930	51.7	1180	31.6	1130	30.3
50	3.4	1010	27.1	2280	61.1	1010	27.1	1060	28.4
60	4.1	1190	31.9	895	24.0	915	24.5	985	26.4
80	5.5	1180	31.6	895	24.0	915	24.5	985	26.4
100	6.9	1070	28.7	895	24.0	915	24.5	985	26.4
125	8.6	810	21.7	895	24.0	915	24.5	985	26.4
psig	bar	Body Size: NPS 1-1/4							
1	69 mbar			200	5.4	260	7.0	310	8.3
2	138 mbar			300	8.0	430	11.5	485	13.0
3	0.21	135	3.6	355	9.5	560	15.0	630	16.9
5	0.34	205	5.5	515	13.8	745	20.0	815	21.8
10	0.69	295	7.9	765	20.5	1290	34.6	1360	36.4
15	1.0	410	11.0	950	25.5	1690	45.3	1910	51.2
20	1.4	505	13.5	1170	31.3	1910	51.2	2270	60.8
30	2.1	665	17.8	1490	39.9	2610	69.9	3260	87.3
40	2.8	860	23.0	1900	50.9	1490	39.9	1830	49.0
50	3.4	995	26.7	2340	62.7	1270	34.0	1490	39.9
60	4.1	1190	31.9	1600	42.9	1110	29.7	1310	35.1
80	5.5	1550	41.5	1430	38.3	1090	29.2	1310	35.1
100	6.9	1550	41.5	1280	34.3	1090	29.2	1310	35.1
125	8.6	1470	39.4	1280	34.3	1090	29.2	1310	35.1

Black areas show where indicated droop/boost would be exceeded regardless of capacity.  
 Gray areas indicate limited capacities due to boost effects.

**Table 24. CS205 and CS206 Series Flow Capacities for 14-inches w.c. / 35 mbar Setpoint**

SETPOINT	ACCURACY		SET RANGE	SPRING PART NUMBER / COLOR
	Droop	Boost		
14 inches w.c. 35 mbar	-2 inches w.c. -5 mbar	2 inches w.c. 5 mbar	10 to 14 inches w.c. 25 to 35 mbar	GE30224X012 / Unpainted

CAPACITIES IN SCFH / Nm <sup>3</sup> /h OF 0.6 SPECIFIC GRAVITY NATURAL GAS									
Inlet Pressure		Orifice Size, Inch / mm							
		18 / 3.2		3/16 / 4.8		1/4 / 6.4		5/16 / 7.9	
		SCFH	Nm <sup>3</sup> /h	SCFH	Nm <sup>3</sup> /h	SCFH	Nm <sup>3</sup> /h	SCFH	Nm <sup>3</sup> /h
psig	bar	Body Size: NPS 3/4							
1	69 mbar			160	4.3	225	6.0	280	7.5
2	138 mbar			260	7.0	375	10.0	455	12.2
3	0.21	135	3.6	355	9.5	480	12.9	635	17.0
5	0.34	200	5.4	460	12.3	690	18.5	790	21.2
10	0.69	335	9.0	735	19.7	1090	29.2	1160	31.1
15	1.0	435	11.7	1020	27.3	1380	37.0	1450	38.8
20	1.4	500	13.4	1160	31.1	1660	44.5	1780	47.7
30	2.1	675	18.1	1540	41.3	2020	54.1	2110	56.5
40	2.8	825	22.1	1920	51.4	2320	62.2	2340	62.7
50	3.4	1020	27.3	2250	60.3	2560	68.6	2520	67.5
60	4.1	1200	32.1	2590	69.4	2700	72.3	2780	74.5
80	5.5	1560	41.8	2940	78.8	2830	75.8	3000	80.4
100	6.9	1700	45.5	3200	85.7	2830	75.8	3000	80.4
125	8.6	1890	50.6	3210	86.0	2830	75.8	3000	80.4
psig	bar	Body Size: NPS 1							
1	69 mbar					280	7.5	360	9.6
2	138 mbar			180	4.8	420	11.3	465	12.5
3	0.21			280	7.5	545	14.6	650	17.4
5	0.34	140	3.8	420	11.3	760	20.4	825	22.1
10	0.69	260	7.0	700	18.8	1210	32.4	1390	37.2
15	1.0	365	9.8	890	23.8	1630	43.7	1840	49.3
20	1.4	465	12.5	1120	30.0	2000	53.6	2160	57.9
30	2.1	620	16.6	1450	38.8	2660	71.3	2910	78.0
40	2.8	810	21.7	1870	50.1	1180	31.6	1440	38.6
50	3.4	975	26.1	2280	61.1	995	26.7	1180	31.6
60	4.1	1150	30.8	950	25.5	950	25.5	1000	26.8
80	5.5	990	26.5	930	24.9	950	25.5	1000	26.8
100	6.9	980	26.3	845	22.6	950	25.5	1000	26.8
125	8.6	980	26.3	845	22.6	950	25.5	1000	26.8
psig	bar	Body Size: NPS 1-1/4							
1	69 mbar			210	5.6	315	8.4	165	4.4
2	138 mbar			260	7.0	415	11.1	440	11.8
3	0.21			380	10.2	555	14.9	715	19.2
5	0.34	140	3.8	520	13.9	735	19.7	905	24.2
10	0.69	250	6.7	720	19.3	1170	31.3	1340	35.9
15	1.0	325	8.7	945	25.3	1470	39.4	1800	48.2
20	1.4	425	11.4	1120	30.0	1870	50.1	2250	60.3
30	2.1	635	17.0	1510	40.5	2470	66.2	3070	82.2
40	2.8	800	21.4	1930	51.7	3200	85.7	3860	103
50	3.4	940	25.2	2260	60.5	3870	103	1510	40.5
60	4.1	1140	30.5	1670	44.7	1370	36.7	1420	38.0
80	5.5	1110	29.7	1330	35.6	1340	35.9	1280	34.3
100	6.9	1090	29.2	1330	35.6	1300	34.8	1280	34.3
125	8.6	1010	27.1	1330	35.6	1300	34.8	1280	34.3

Black areas show where indicated droop/boost would be exceeded regardless of capacity.  
 Gray areas indicate limited capacities due to boost effects.

# Bulletin 71.1:CS200

**Table 25. CS205 and CS206 Series Flow Capacities for 1 psig / 69 mbar Setpoint at 1% Accuracy**

SETPOINT	ACCURACY		SET RANGE	SPRING PART NUMBER / COLOR
	+ / - 1% ABS			
1 psig	-0.16 psi	0.16 psi	18 inches w.c. to 1 psig	GE30225X012 / Orange
69 mbar	-11 mbar	11 mbar	45 to 69 mbar	

CAPACITIES IN SCFH / Nm <sup>3</sup> /h OF 0.6 SPECIFIC GRAVITY NATURAL GAS									
Inlet Pressure		Orifice Size, Inch / mm							
		18 / 3.2		3/16 / 4.8		1/4 / 6.4		5/16 / 7.9	
		SCFH	Nm <sup>3</sup> /h	SCFH	Nm <sup>3</sup> /h	SCFH	Nm <sup>3</sup> /h	SCFH	Nm <sup>3</sup> /h
psig	bar	Body Size: NPS 3/4							
2	138 mbar			235	6.3	360	9.6	515	13.8
3	0.21	125	3.3	330	8.8	480	12.9	645	17.3
5	0.34	160	4.3	470	12.6	705	18.9	825	22.1
10	0.69	330	8.8	700	18.8	1070	28.7	1320	35.4
15	1.0	375	10.0	960	25.7	1380	37.0	1880	50.4
20	1.4	500	13.4	1160	31.1	1700	45.5	1630	43.7
30	2.1	585	15.7	1590	42.6	2140	57.3	2360	63.2
40	2.8	795	21.3	1900	50.9	2560	68.6	2620	70.2
50	3.4	975	26.1	2260	60.5	2840	76.1	2950	79.0
60	4.1	1110	29.7	2600	69.7	3030	81.2	3100	83.1
80	5.5	1370	36.7	3280	87.9	3370	90.3	3370	90.3
90	6.2	1480	39.7	3350	89.7	3520	94.3	3390	90.8
100	6.9	1670	44.7	3520	94.3	3520	94.3	3390	90.8
psig	bar	Body Size: NPS 1							
2	138 mbar			165	4.4	295	7.9	390	10.4
3	0.21			260	7.0	430	11.5	540	14.5
5	0.34	135	3.6	405	10.9	630	16.9	785	21.0
10	0.69	260	7.0	680	18.2	1020	27.3	1320	35.4
15	1.0	345	9.2	920	24.6	1400	37.5	1770	47.4
20	1.4	435	11.7	1100	29.5	1810	48.5	2190	58.7
30	2.1	605	16.2	1490	39.9	2370	63.5	2860	76.6
40	2.8	810	21.7	1880	50.4	2990	80.1	3410	91.4
50	3.4	955	25.6	2260	60.5	3510	94.0	3870	103
60	4.1	1120	30.0	2610	69.9	3930	105	4280	114
80	5.5	1490	39.9	3360	90.0	4620	123	4990	133
90	6.2	1670	44.7	3750	100	4830	129	5000	134
100	6.9	1840	49.3	4130	110	4880	130	5000	134
psig	bar	Body Size: NPS 1-1/4							
2	138 mbar			275	7.4	380	10.2	460	12.3
3	0.21			335	9.0	505	13.5	640	17.1
5	0.34	135	3.6	485	13.0	730	19.6	920	24.6
10	0.69	255	6.8	760	20.4	1150	30.8	1480	39.7
15	1.0	350	9.4	960	25.7	1530	41.0	1940	52.0
20	1.4	450	12.1	1120	30.0	1860	49.8	2340	62.7
30	2.1	600	16.1	1410	37.8	2450	65.6	3090	82.8
40	2.8	785	21.0	1880	50.4	3240	86.8	3880	103
50	3.4	960	25.7	2300	61.6	3790	101	4520	121
60	4.1	1140	30.5	2610	69.9	4490	120	5150	138
80	5.5	1490	39.9	3400	91.1	5580	149	6120	164
90	6.2	1650	44.2	3860	103	6210	166	5870	157
100	6.9	1820	48.8	4220	113	3020	80.9	5490	147

     Black areas show where indicated droop/boost would be exceeded regardless of capacity.  
     Gray areas indicate limited capacities due to boost effects.

**Table 26. CS205 and CS206 Series Flow Capacities for 1 psig / 69 mbar Setpoint at 2% Accuracy**

SETPOINT	ACCURACY		SET RANGE	SPRING PART NUMBER / COLOR
	+ / - 2% ABS			
1 psig	-0.31 psi	0.31 psi	18 inches w.c. to 1 psig	GE30225X012 / Orange
69 mbar	-21 mbar	21 mbar	45 to 69 mbar	

CAPACITIES IN SCFH / Nm <sup>3</sup> /h OF 0.6 SPECIFIC GRAVITY NATURAL GAS									
Inlet Pressure		Orifice Size, Inch / mm							
		18 / 3.2		3/16 / 4.8		1/4 / 6.4		5/16 / 7.9	
		SCFH	Nm <sup>3</sup> /h	SCFH	Nm <sup>3</sup> /h	SCFH	Nm <sup>3</sup> /h	SCFH	Nm <sup>3</sup> /h
psig	bar	Body Size: NPS 3/4							
2	138 mbar			270	7.2	445	11.9	625	16.7
3	0.21	145	3.9	375	10.0	635	17.0	725	19.4
5	0.34	190	5.1	525	14.1	840	22.5	1060	28.4
10	0.69	355	9.5	805	21.6	1280	34.3	1580	42.3
15	1.0	425	11.4	1000	26.8	1670	44.7	2380	63.8
20	1.4	525	14.1	1180	31.6	1990	53.3	2060	55.2
30	2.1	655	17.5	1590	42.6	2610	69.9	2910	78.0
40	2.8	850	22.8	1920	51.4	3040	81.4	3300	88.4
50	3.4	1030	27.6	2270	60.8	3390	90.8	3540	94.8
60	4.1	1190	31.9	2660	71.3	3600	96.4	3750	100
80	5.5	1480	39.7	3460	92.7	3890	104	3910	104
90	6.2	1620	43.4	3690	98.9	4090	109	3860	103
100	6.9	1800	48.2	4010	107	4150	111	3860	103
psig	bar	Body Size: NPS 1							
2	138 mbar			200	5.4	370	9.9	520	13.9
3	0.21			300	8.0	540	14.5	690	18.5
5	0.34	145	3.9	460	12.3	785	21.0	1020	27.3
10	0.69	270	7.2	750	20.1	1300	34.8	1630	43.7
15	1.0	365	9.8	945	25.3	1680	45.0	2120	56.8
20	1.4	440	11.8	1140	30.5	2030	54.4	2660	71.3
30	2.1	620	16.6	1520	40.7	2700	72.3	3430	91.9
40	2.8	810	21.7	1920	51.4	3240	86.8	4020	107
50	3.4	975	26.1	2270	60.8	3870	103	4500	120
60	4.1	1130	30.3	2640	70.7	4420	118	4920	131
80	5.5	1490	39.9	3400	91.1	5090	136	5250	140
90	6.2	1670	44.7	3800	101	5090	136	5250	140
100	6.9	1840	49.3	4170	111	5090	136	5250	140
psig	bar	Body Size: NPS 1-1/4							
2	138 mbar			300	8.0	460	12.3	615	16.5
3	0.21			375	10.0	595	15.9	800	21.4
5	0.34	145	3.9	535	14.3	860	23.0	1050	28.1
10	0.69	275	7.4	800	21.4	1340	35.9	1660	44.5
15	1.0	365	9.8	1010	27.1	1710	45.8	2210	59.2
20	1.4	450	12.1	1170	31.3	2030	54.4	2600	69.7
30	2.1	620	16.6	1520	40.7	2630	70.5	3480	93.2
40	2.8	790	21.2	1900	50.9	3430	91.9	4280	114
50	3.4	960	25.7	2280	61.1	4080	109	5060	135
60	4.1	1140	30.5	2630	70.5	4540	121	5780	154
80	5.5	1490	39.9	3420	91.6	5920	158	5950	159
90	6.2	1650	44.2	3860	103	5920	158	5950	159
100	6.9	1820	48.8	4180	112	5920	158	5950	159

     Black areas show where indicated droop/boost would be exceeded regardless of capacity.  
     Gray areas indicate limited capacities due to boost effects.



# Bulletin 71.1:CS200

**Table 27. CS205 and CS206 Series Flow Capacities for 1 psig / 69 mbar Setpoint at 10% Accuracy**

SETPOINT	ACCURACY		SET RANGE	SPRING PART NUMBER / COLOR
	+ / - 10%			
1 psig	-0.1 psi	0.1 psi	18 inches w.c. to 1 psig	GE30225X012 / Orange
69 mbar	-7 mbar	7 mbar	45 to 69 mbar	

CAPACITIES IN SCFH / Nm <sup>3</sup> /h OF 0.6 SPECIFIC GRAVITY NATURAL GAS									
Inlet Pressure		Orifice Size, Inch / mm							
		18 / 3.2		3/16 / 4.8		1/4 / 6.4		5/16 / 7.9	
		SCFH	Nm <sup>3</sup> /h	SCFH	Nm <sup>3</sup> /h	SCFH	Nm <sup>3</sup> /h	SCFH	Nm <sup>3</sup> /h
psig	bar	Body Size: NPS 3/4							
2	138 mbar			210	5.6	285	7.6	505	13.5
3	0.21	120	3.2	295	7.9	400	10.7	495	13.3
5	0.34	150	4.0	410	11.0	605	16.2	790	21.2
10	0.69	310	8.3	650	17.4	915	24.5	1090	29.2
15	1.0	350	9.4	915	24.5	1180	31.6	1710	45.8
20	1.4	465	12.5	1110	29.7	1480	39.7	1450	38.8
30	2.1	540	14.5	1520	40.7	1900	50.9	2120	56.8
40	2.8	755	20.2	1870	50.1	2360	63.2	2320	62.2
50	3.4	940	25.2	2170	58.1	2620	70.2	2640	70.7
60	4.1	1070	28.7	2460	65.9	2720	72.9	2830	75.8
80	5.5	1300	34.8	2960	79.3	3110	83.3	3050	81.7
90	6.2	1390	37.2	2970	79.6	3250	87.1	3050	81.7
100	6.9	1580	42.3	3130	83.9	3330	89.2	3160	84.7
psig	bar	Body Size: NPS 1							
2	138 mbar			155	4.2	250	6.7	310	8.3
3	0.21			235	6.3	340	9.1	425	11.4
5	0.34	130	3.5	355	9.5	520	13.9	610	16.3
10	0.69	250	6.7	615	16.5	840	22.5	1060	28.4
15	1.0	330	8.8	885	23.7	1210	32.4	1530	41.0
20	1.4	430	11.5	1060	28.4	1610	43.1	1940	52.0
30	2.1	585	15.7	1440	38.6	2170	58.1	2610	69.9
40	2.8	810	21.7	1820	48.8	2700	72.3	3150	84.4
50	3.4	935	25.0	2230	59.7	3300	88.4	3640	97.5
60	4.1	1110	29.7	2560	68.6	3690	98.9	3990	106
80	5.5	1490	39.9	3320	88.9	1390	37.2	1790	48.0
90	6.2	1640	43.9	3690	98.9	1170	31.3	1680	45.0
100	6.9	1790	48.0	4070	109	1090	29.2	1680	45.0
psig	bar	Body Size: NPS 1-1/4							
2	138 mbar			195	5.2	335	9.0	375	10.0
3	0.21			315	8.4	450	12.1	475	12.7
5	0.34	130	3.5	430	11.5	615	16.5	780	20.9
10	0.69	235	6.3	710	19.0	1010	27.1	1270	34.0
15	1.0	330	8.8	890	23.8	1390	37.2	1720	46.1
20	1.4	430	11.5	1070	28.7	1700	45.5	2090	56.0
30	2.1	585	15.7	1350	36.2	2270	60.8	2890	77.4
40	2.8	775	20.8	1850	49.6	3100	83.1	3680	98.6
50	3.4	960	25.7	2280	61.1	3700	99.1	4330	116
60	4.1	1110	29.7	2600	69.7	4420	118.4	4700	125
80	5.5	1490	39.9	3390	90.8	2610	69.9	2160	57.9
90	6.2	1650	44.2	2810	75.3	2050	54.9	2010	53.8
100	6.9	1800	48.2	2440	65.4	1920	51.4	2010	53.8

Black areas show where indicated droop/boost would be exceeded regardless of capacity.  
 Gray areas indicate limited capacities due to boost effects.

**Table 28. CS205 and CS206 Series Flow Capacities for 1 psig / 69 mbar Setpoint at 20% Accuracy**

SETPOINT	ACCURACY		SET RANGE	SPRING PART NUMBER / COLOR
	+ / - 20%			
1 psig	-0.2 psi	0.2 psi	18 inches w.c. to 1 psig	GE30225X012 / Orange
69 mbar	-14 mbar	14 mbar	45 to 69 mbar	

CAPACITIES IN SCFH / Nm <sup>3</sup> /h OF 0.6 SPECIFIC GRAVITY NATURAL GAS									
Inlet Pressure		Orifice Size, Inch / mm							
		18 / 3.2		3/16 / 4.8		1/4 / 6.4		5/16 / 7.9	
		SCFH	Nm <sup>3</sup> /h	SCFH	Nm <sup>3</sup> /h	SCFH	Nm <sup>3</sup> /h	SCFH	Nm <sup>3</sup> /h
psig	bar	Body Size: NPS 3/4							
2	138 mbar			250	6.7	410	11.0	525	14.1
3	0.21	130	3.5	345	9.2	530	14.2	660	17.7
5	0.34	170	4.6	495	13.3	755	20.2	895	24.0
10	0.69	340	9.1	745	20.0	1170	31.3	1470	39.4
15	1.0	400	10.7	980	26.3	1490	39.9	2060	55.2
20	1.4	505	13.5	1170	31.3	1820	48.8	1770	47.4
30	2.1	605	16.2	1590	42.6	2300	61.6	2560	68.6
40	2.8	810	21.7	1920	51.4	2720	72.9	2850	76.4
50	3.4	1000	26.8	2270	60.8	3000	80.4	3110	83.3
60	4.1	1150	30.8	2650	71.0	3200	85.7	3330	89.2
80	5.5	1430	38.3	3460	92.7	3500	93.8	3540	94.8
90	6.2	1520	40.7	3560	95.4	3710	99.4	3540	94.8
100	6.9	1710	45.8	3690	98.9	3720	99.7	3560	95.4
psig	bar	Body Size: NPS 1							
2	138 mbar			180	4.8	325	8.7	440	11.8
3	0.21			275	7.4	475	12.7	595	15.9
5	0.34	140	3.8	430	11.5	710	19.0	895	24.0
10	0.69	265	7.1	720	19.3	1120	30.0	1460	39.1
15	1.0	365	9.8	930	24.9	1500	40.2	1890	50.6
20	1.4	435	11.7	1120	30.0	1960	52.5	2380	63.8
30	2.1	610	16.3	1500	40.2	2530	67.8	3060	82.0
40	2.8	810	21.7	1900	50.9	3120	83.6	3620	97.0
50	3.4	965	25.9	2260	60.5	3630	97.3	4100	109
60	4.1	1130	30.3	2620	70.2	4090	109	4500	120
80	5.5	1490	39.9	3380	90.6	4800	128	5100	136
90	6.2	1670	44.7	3780	101	5030	134	5100	136
100	6.9	1840	49.3	4150	111	5030	134	5100	136
psig	bar	Body Size: NPS 1-1/4							
2	138 mbar			290	7.8	410	11.0	530	14.2
3	0.21			350	9.4	540	14.5	725	19.4
5	0.34	140	3.8	505	13.5	785	21.0	965	25.9
10	0.69	265	7.1	775	20.8	1220	32.7	1560	41.8
15	1.0	360	9.6	980	26.3	1620	43.4	2060	55.2
20	1.4	450	12.1	1130	30.3	1930	51.7	2450	65.6
30	2.1	620	16.6	1460	39.1	2520	67.5	3260	87.3
40	2.8	785	21.0	1890	50.6	3430	91.9	4050	108
50	3.4	960	25.7	2290	61.4	3890	104	4760	127
60	4.1	1140	30.5	2620	70.2	4520	121	5410	144
80	5.5	1490	39.9	3410	91.4	5660	151	5660	151
90	6.2	1650	44.2	3860	103	5660	151	5660	151
100	6.9	1820	48.8	4230	113	5660	151	5660	151

Black areas show where indicated droop/boost would be exceeded regardless of capacity.

# Bulletin 71.1:CS200

**Table 29. CS205 and CS206 Series Flow Capacities for 2 psig / 138 mbar Setpoint at 1% Accuracy**

SETPOINT	ACCURACY		SET RANGE	SPRING PART NUMBER / COLOR
	+ / - 1% ABS			
2 psig	-0.17 psi	0.17 psi	1 to 2 psig	GE30190X012 / Black
138 mbar	-12 mbar	12 mbar	69 to 138 mbar	

CAPACITIES IN SCFH / Nm <sup>3</sup> /h OF 0.6 SPECIFIC GRAVITY NATURAL GAS									
Inlet Pressure		Orifice Size, Inch / mm							
		18 / 3.2		3/16 / 4.8		1/4 / 6.4		5/16 / 7.9	
		SCFH	Nm <sup>3</sup> /h	SCFH	Nm <sup>3</sup> /h	SCFH	Nm <sup>3</sup> /h	SCFH	Nm <sup>3</sup> /h
psig	bar	Body Size: NPS 3/4							
3	0.21	110	2.9	200	5.4	350	9.4	310	8.3
5	0.34	145	3.9	325	8.7	455	12.2	570	15.3
10	0.69	255	6.8	540	14.5	765	20.5	930	24.9
15	1.0	350	9.4	775	20.8	1060	28.4	1230	33.0
20	1.4	465	12.5	980	26.3	1330	35.6	1540	41.3
30	2.1	630	16.9	1370	36.7	1790	48.0	1920	51.4
40	2.8	755	20.2	1750	46.9	2180	58.4	2330	62.4
50	3.4	905	24.2	2110	56.5	2510	67.2	2530	67.8
60	4.1	1030	27.6	2360	63.2	2740	73.4	2820	75.6
80	5.5	1290	34.6	2880	77.2	3280	87.9	3080	82.5
90	6.2	1480	39.7	2960	79.3	3380	90.6	3240	86.8
100	6.9	1510	40.5	3170	84.9	3490	93.5	3320	88.9
psig	bar	Body Size: NPS 1							
3	0.21			155	4.2	280	7.5	275	7.4
5	0.34	120	3.2	280	7.5	410	11.0	485	13.0
10	0.69	225	6.0	550	14.7	695	18.6	830	22.2
15	1.0	355	9.5	750	20.1	1030	27.6	1220	32.7
20	1.4	420	11.3	985	26.4	1290	34.6	1590	42.6
30	2.1	575	15.4	1410	37.8	1900	50.9	2230	59.7
40	2.8	755	20.2	1780	47.7	2320	62.2	2730	73.1
50	3.4	955	25.6	2180	58.4	2920	78.2	3240	86.8
60	4.1	1100	29.5	2510	67.2	3400	91.1	3680	98.6
80	5.5	1430	38.3	3170	84.9	4170	112	4360	117
90	6.2	1620	43.4	3640	97.5	4430	119	4590	123
100	6.9	1710	45.8	3890	104	4550	122	4930	132
psig	bar	Body Size: NPS 1-1/4							
3	0.21			255	6.8	315	8.4	465	12.5
5	0.34			350	9.4	445	11.9	610	16.3
10	0.69	225	6.0	535	14.3	815	21.8	1040	27.9
15	1.0	335	9.0	775	20.8	1140	30.5	1430	38.3
20	1.4	420	11.3	965	25.9	1440	38.6	1780	47.7
30	2.1	605	16.2	1320	35.4	2020	54.1	2540	68.0
40	2.8	775	20.8	1720	46.1	2690	72.1	3240	86.8
50	3.4	940	25.2	2020	54.1	3360	90.0	3990	107
60	4.1	1120	30.0	2490	66.7	3800	102	4440	119
80	5.5	1440	38.6	3300	88.4	4940	132	5670	152
90	6.2	1680	45.0	3630	97.3	5460	146	5770	155
100	6.9	1820	48.8	3960	106	5750	154	5770	155

Black areas show where indicated droop/boost would be exceeded regardless of capacity.

**Table 30. CS205 and CS206 Series Flow Capacities for 2 psig / 138 mbar Setpoint at 2% Accuracy**

SETPOINT	ACCURACY		SET RANGE	SPRING PART NUMBER / COLOR
	+ / - 2% ABS			
2 psig	-0.33 psi	0.33 psi	1 to 2 psig	GE30190X012 / Black
138 mbar	-23 mbar	23 mbar	69 to 138 mbar	

CAPACITIES IN SCFH / Nm <sup>3</sup> /h OF 0.6 SPECIFIC GRAVITY NATURAL GAS									
Inlet Pressure		Orifice Size, Inch / mm							
		18 / 3.2		3/16 / 4.8		1/4 / 6.4		5/16 / 7.9	
		SCFH	Nm <sup>3</sup> /h	SCFH	Nm <sup>3</sup> /h	SCFH	Nm <sup>3</sup> /h	SCFH	Nm <sup>3</sup> /h
psig	bar	Body Size: NPS 3/4							
3	0.21	120	3.2	255	6.8	460	12.3	560	15.0
5	0.34	165	4.4	410	11.0	640	17.1	800	21.4
10	0.69	295	7.9	710	19.0	1060	28.4	1310	35.1
15	1.0	400	10.7	960	25.7	1420	38.0	1660	44.5
20	1.4	510	13.7	1160	31.1	1710	45.8	1970	52.8
30	2.1	675	18.1	1540	41.3	2270	60.8	2520	67.5
40	2.8	815	21.8	1930	51.7	2750	73.7	2910	78.0
50	3.4	990	26.5	2280	61.1	3100	83.1	3290	88.1
60	4.1	1100	29.5	2670	71.5	3420	91.6	3520	94.3
80	5.5	1400	37.5	3380	90.6	3910	105	3840	103
90	6.2	1590	42.6	3690	98.9	4030	108	3870	104
100	6.9	1650	44.2	3900	104	4110	110	3990	107
psig	bar	Body Size: NPS 1							
3	0.21			195	5.2	370	9.9	455	12.2
5	0.34	125	3.3	360	9.6	560	15.0	730	19.6
10	0.69	250	6.7	665	17.8	1000	26.8	1250	33.5
15	1.0	360	9.6	920	24.6	1400	37.5	1630	43.7
20	1.4	475	12.7	1080	28.9	1740	46.6	2150	57.6
30	2.1	610	16.3	1490	39.9	2390	64.0	2870	76.9
40	2.8	810	21.7	1890	50.6	3000	80.4	3470	93.0
50	3.4	1000	26.8	2300	61.6	3540	94.8	4010	107
60	4.1	1150	30.8	2610	69.9	4010	107	4480	120
80	5.5	1500	40.2	3350	89.7	4830	129	5180	139
90	6.2	1640	43.9	3810	102	5170	138	5310	142
100	6.9	1760	47.2	4070	109	5240	140	5460	146
psig	bar	Body Size: NPS 1-1/4							
3	0.21			335	9.0	410	11.0	590	15.8
5	0.34			445	11.9	615	16.5	830	22.2
10	0.69	245	6.6	680	18.2	1110	29.7	1390	37.2
15	1.0	345	9.2	965	25.9	1470	39.4	1810	48.5
20	1.4	430	11.5	1110	29.7	1850	49.6	2250	60.3
30	2.1	605	16.2	1500	40.2	2500	67.0	3000	80.4
40	2.8	785	21.0	1890	50.6	3180	85.2	3710	99.4
50	3.4	945	25.3	2180	58.4	3770	101	4640	124
60	4.1	1120	30.0	2590	69.4	4440	119	5110	137
80	5.5	1450	38.8	3380	90.6	5630	151	6170	165
90	6.2	1680	45.0	3770	101	6080	163	6350	170
100	6.9	1850	49.6	4080	109	6350	170	6350	170

Black areas show where indicated droop/boost would be exceeded regardless of capacity.

# Bulletin 71.1:CS200

**Table 31. CS205 and CS206 Series Flow Capacities for 2 psig / 138 mbar Setpoint at 10% Accuracy**

SETPOINT	ACCURACY		SET RANGE	SPRING PART NUMBER / COLOR
	+ / - 10%			
2 psig	-0.2 psi	0.2 psi	1 to 2 psig	GE30190X012 / Black
138 mbar	-14 mbar	14 mbar	69 to 138 mbar	

CAPACITIES IN SCFH / Nm <sup>3</sup> /h OF 0.6 SPECIFIC GRAVITY NATURAL GAS											
Inlet Pressure		Orifice Size, Inch / mm									
		18 / 3.2		3/16 / 4.8		1/4 / 6.4		5/16 / 7.9		1/2 / 12.7	
		SCFH	Nm <sup>3</sup> /h	SCFH	Nm <sup>3</sup> /h	SCFH	Nm <sup>3</sup> /h	SCFH	Nm <sup>3</sup> /h	SCFH	Nm <sup>3</sup> /h
psig	bar	Body Size: NPS 3/4									
3	0.21			100	2.7	180	4.8	320	8.6	460	12.3
5	0.34			210	5.6	380	10.2	590	15.8	830	22.2
10	0.69	150	4.0	420	11.3	720	19.3	1070	28.7	1530	41.0
15	1.0	310	8.3	620	16.6	1050	28.1	1570	42.1	1900	50.9
20	1.4	400	10.7	810	21.7	1370	36.7	1800	48.2	2120	56.8
25	1.7	490	13.1	950	25.5	1680	45.0	2150	57.6	2475	66.3
30	2.1	540	14.5	1120	30.0	1850	49.6	2150	57.6	2475	66.3
40	2.8	680	18.2	1420	38.1	2170	58.2	2450	65.7	2575	69.0
50	3.4	820	22.0	1790	48.0	2470	66.2	2570	68.9		
60	4.1	1000	26.8	2060	55.2	2600	69.7	2670	71.6		
80	5.5	1300	34.8	2470	66.2	2850	76.4				
100	6.9	1600	42.9	2720	72.9	2850	76.4				
125	8.6	1970	52.8	2850	76.4						
psig	bar	Body Size: NPS 1									
3	0.21			110	2.9	120	3.2	310	8.3	470	12.6
5	0.34			200	5.4	350	9.4	610	16.3	770	20.6
10	0.69	140	3.8	390	10.5	720	19.3	1020	27.3	1340	35.9
15	1.0	210	5.6	700	18.8	1000	26.8	1380	37.0	1680	45.0
20	1.4	420	11.3	910	24.4	1290	34.6	1750	46.9	2010	53.9
25	1.7	490	13.1	1080	28.9	1530	41.0	2000	53.6	2250	60.3
30	2.1	550	14.7	1230	33.0	1750	46.9	2180	58.4	2510	67.3
40	2.8	700	18.8	1490	39.9	2170	58.2	2600	69.7	2900	77.7
50	3.4	860	23.0	1840	49.3	2520	67.5	2750	73.7		
60	4.1	1000	26.8	2170	58.2	2850	76.4	3030	81.2		
80	5.5	1300	34.8	2590	69.4	3010	80.7				
100	6.9	1600	42.9	2860	76.6	3160	84.7				
125	8.6	1970	52.8	3110	83.3						
psig	bar	Body Size: NPS 1-1/4									
3	0.21			110	2.9	150	4.0	250	6.7	400	10.7
5	0.34			190	5.1	330	8.8	580	15.5	680	18.2
10	0.69	190	5.1	390	10.5	680	18.2	1170	31.4	1480	39.7
15	1.0	300	8.0	540	14.5	940	25.2	1770	47.4	2300	61.6
20	1.4	340	9.1	660	17.7	1270	34.0	2290	61.4	2860	76.6
25	1.7	480	12.9	860	23.0	1630	43.7	2840	76.1	3610	96.7
30	2.1	550	14.7	1070	28.7	1940	52.0	3220	86.3	3980	107
40	2.8	670	18.0	1480	39.7	2790	74.8	4140	111	5230	140
50	3.4	810	21.7	1730	46.4	3270	87.6	5290	142		
60	4.1	940	25.2	2030	54.4	4000	107	5400	145		
80	5.5	1300	34.8	2740	73.4	4400	118				
100	6.9	1500	40.2	3380	90.6	4400	118				
125	8.6	1900	50.9	4070	109						

Black areas show where indicated droop/boost would be exceeded regardless of capacity.

**Table 32. CS205 and CS206 Series Flow Capacities for 2 psig / 138 mbar Setpoint at 20% Accuracy**

SETPOINT	ACCURACY		SET RANGE	SPRING PART NUMBER / COLOR
	+ / - 20%			
2 psig	-0.4 psi	0.4 psi	1 to 2 psig	GE30190X012 / Black
138 mbar	-28 mbar	28 mbar	69 to 138 mbar	

CAPACITIES IN SCFH / Nm <sup>3</sup> /h OF 0.6 SPECIFIC GRAVITY NATURAL GAS									
Inlet Pressure		Orifice Size, Inch / mm							
		18 / 3.2		3/16 / 4.8		1/4 / 6.4		5/16 / 7.9	
		SCFH	Nm <sup>3</sup> /h	SCFH	Nm <sup>3</sup> /h	SCFH	Nm <sup>3</sup> /h	SCFH	Nm <sup>3</sup> /h
psig	bar	Body Size: NPS 3/4							
3	0.21	125	3.3	270	7.2	490	13.1	600	16.1
5	0.34	170	4.6	430	11.5	690	18.5	865	23.2
10	0.69	305	8.2	750	20.1	1140	30.5	1400	37.5
15	1.0	415	11.1	985	26.4	1490	39.9	1750	46.9
20	1.4	520	13.9	1180	31.6	1840	49.3	2100	56.3
30	2.1	690	18.5	1570	42.1	2400	64.3	2700	72.3
40	2.8	840	22.5	1930	51.7	2880	77.2	3140	84.1
50	3.4	1000	26.8	2290	61.4	3320	88.9	3520	94.3
60	4.1	1140	30.5	2670	71.5	3670	98.3	3820	102
80	5.5	1400	37.5	3400	91.1	4110	110	4120	110
90	6.2	1620	43.4	3770	101	4250	114	4130	111
100	6.9	1680	45.0	4100	110	4350	116	4240	114
psig	bar	Body Size: NPS 1							
3	0.21	125	3.3	210	5.6	395	10.6	510	13.7
5	0.34	170	4.6	375	10.0	605	16.2	795	21.3
10	0.69	255	6.8	690	18.5	1070	28.7	1370	36.7
15	1.0	360	9.6	935	25.0	1510	40.5	1760	47.2
20	1.4	475	12.7	1110	29.7	1870	50.1	2310	61.9
30	2.1	635	17.0	1500	40.2	2510	67.2	3050	81.7
40	2.8	810	21.7	1920	51.4	3120	83.6	3700	99.1
50	3.4	1000	26.8	2300	61.6	3680	98.6	4230	113
60	4.1	1150	30.8	2620	70.2	4180	112	4700	126
80	5.5	1500	40.2	3370	90.3	5040	135	5370	144
90	6.2	1640	43.9	3810	102	5360	144	5570	149
100	6.9	1770	47.4	4140	111	5460	146	5630	151
psig	bar	Body Size: NPS 1-1/4							
3	0.21	250	6.7	345	9.2	465	12.5	620	16.6
5	0.34	345	9.2	485	13.0	650	17.4	865	23.2
10	0.69	520	13.9	715	19.2	1170	31.3	1470	39.4
15	1.0	690	18.5	995	26.7	1530	41.0	2010	53.8
20	1.4	840	22.5	1160	31.1	1890	50.6	2350	63.0
30	2.1	1140	30.5	1530	41.0	2720	72.9	3100	83.1
40	2.8	1380	37.5	1910	51.2	3270	87.6	3880	104
50	3.4	1540	41.1	2220	59.5	3840	103	4780	128
60	4.1	1720	45.5	2610	69.9	4660	125	5200	139
80	5.5	2200	58.1	3390	90.8	5760	154	6550	175
90	6.2	2380	63.8	3790	101	6250	167	6550	175
100	6.9	2500	66.9	4090	110	6550	175	6550	175

Black areas show where indicated droop/boost would be exceeded regardless of capacity.

# Bulletin 71.1:CS200

**Table 33. CS200 Series Internal Registration Flow Capacities for 2 psig / 138 mbar Setpoint with 1% ABS Pressure Factor Accuracy (PFM Approved)**

SETPOINT	ACCURACY		SET RANGE	SPRING PART NUMBER / COLOR
	+ / - 1% ABS			
2 psig	-0.17 psi	0.17 psi	1 to 2 psig	GE30190X012 / Black
138 mbar	-12 mbar	12 mbar	69 to 138 mbar	

CAPACITIES IN SCFH / Nm <sup>3</sup> /h OF 0.6 SPECIFIC GRAVITY NATURAL GAS											
Inlet Pressure		Orifice Size, Inch / mm									
		1/8 / 3.2		3/16 / 4.8		1/4 / 6.4		3/8 / 9.5		1/2 / 13	
		SCFH	Nm <sup>3</sup> /h	SCFH	Nm <sup>3</sup> /h	SCFH	Nm <sup>3</sup> /h	SCFH	Nm <sup>3</sup> /h	SCFH	Nm <sup>3</sup> /h
psig	bar	Body Size: NPS 3/4									
3	0.21			100	2.7	180	4.8	320	8.6	460	12.3
5	0.34			210	5.6	380	10.2	590	15.8	830	22.2
10	0.69	150	4.0	420	11.3	720	19.3	1070	28.7	1530	41.0
15	1.0	310	8.3	620	16.6	1050	28.1	1570	42.1	1900	50.9
20	1.4	400	10.7	810	21.7	1370	36.7	1800	48.2	2120	56.8
25	1.7	490	13.1	950	25.5	1680	45.0	2150	57.6	2475	66.3
30	2.0	540	14.5	1120	30.0	1850	49.6	2150	57.6	2475	66.3
40	2.7	680	18.2	1420	38.1	2170	58.2	2450	65.7	2575	69.0
50	3.4	820	22.0	1790	48.0	2470	66.2	2570	68.9		
60	4.1	1000	26.8	2060	55.2	2600	69.7	2670	71.6		
80	5.5	1300	34.8	2470	66.2	2850	76.4				
100	6.8	1600	42.9	2720	72.9	2850	76.4				
125	8.5	1970	52.8	2850	76.4						
psig	bar	Body Size: NPS 1									
3	0.21			110	2.9	120	3.2	310	8.3	470	12.6
5	0.34			200	5.4	350	9.4	610	16.3	770	20.6
10	0.69	140	3.8	390	10.5	720	19.3	1020	27.3	1340	35.9
15	1.0	210	5.6	700	18.8	1000	26.8	1380	37.0	1680	45.0
20	1.4	420	11.3	910	24.4	1290	34.6	1750	46.9	2010	53.9
25	1.7	490	13.1	1080	28.9	1530	41.0	2000	53.6	2250	60.3
30	2.0	550	14.7	1230	33.0	1750	46.9	2180	58.4	2510	67.3
40	2.7	700	18.8	1490	39.9	2170	58.2	2600	69.7	2900	77.7
50	3.4	860	23.0	1840	49.3	2520	67.5	2750	73.7		
60	4.1	1000	26.8	2170	58.2	2850	76.4	3030	81.2		
80	5.5	1300	34.8	2590	69.4	3010	80.7				
100	6.8	1600	42.9	2860	76.6	3160	84.7				
125	8.5	1970	52.8	3110	83.3						
psig	bar	Body Size: NPS 1-1/4									
3	0.21			110	2.9	150	4.0	250	6.7	400	10.7
5	0.34			190	5.1	330	8.8	580	15.5	680	18.2
10	0.69	190	5.1	390	10.5	680	18.2	1170	31.4	1480	39.7
15	1.0	300	8.0	540	14.5	940	25.2	1770	47.4	2300	61.6
20	1.4	340	9.1	660	17.7	1270	34.0	2290	61.4	2860	76.6
25	1.7	480	12.9	860	23.0	1630	43.7	2840	76.1	3610	96.7
30	2.0	550	14.7	1070	28.7	1940	52.0	3220	86.3	3980	107
40	2.7	670	18.0	1480	39.7	2790	74.8	4140	111	5230	140
50	3.4	810	21.7	1730	46.4	3270	87.6	5290	142		
60	4.1	940	25.2	2030	54.4	4000	107	5400	145		
80	5.5	1300	34.8	2740	73.4	4400	118				
100	6.8	1500	40.2	3380	90.6	4400	118				
125	8.5	1900	50.9	4070	109						

Black areas show where indicated droop/boost would be exceeded regardless of capacity.

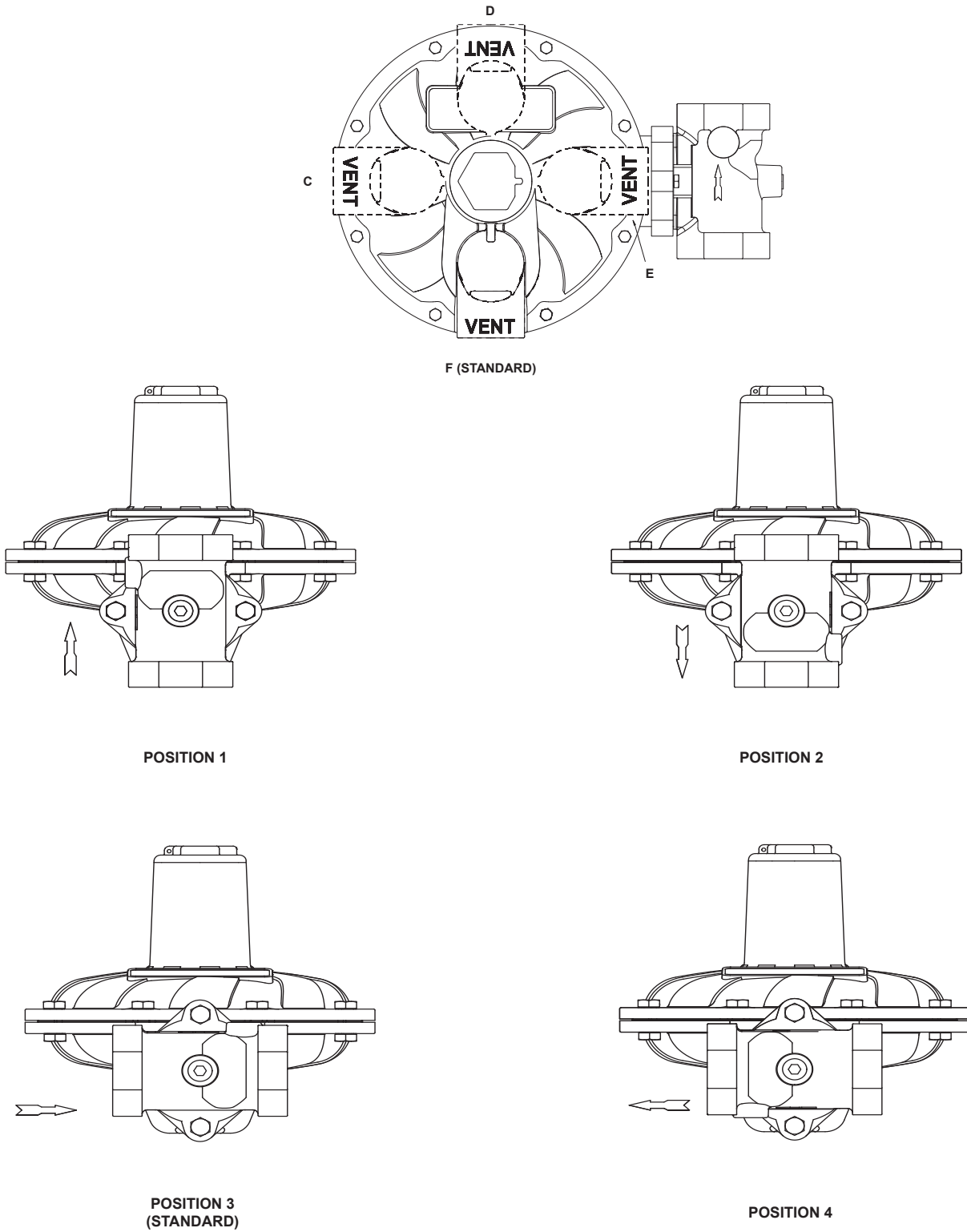

GE26479-A\_S6

Figure 9. Spring Case Vent and Body Orientation



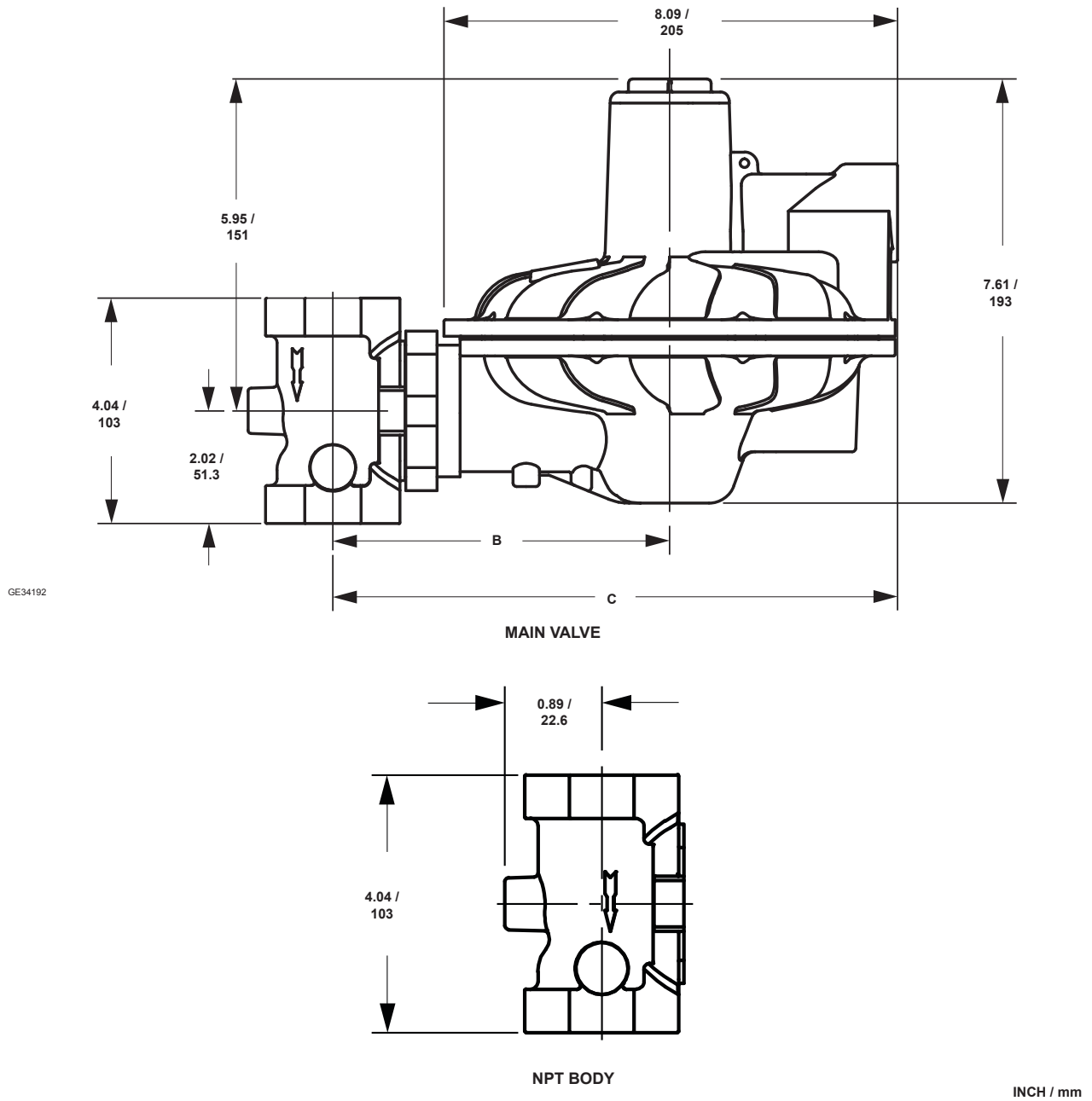

Figure 10. Dimensions

Table 34. Body Size and Dimensions

BODY SIZE, NPS		DIMENSION, INCH / mm	
Inlet	Outlet	B	C
3/4	3/4	5.84 / 148	9.93 / 252
3/4	1		
1			
3/4	1-1/4	6.02 / 153	10.1 / 257
1			
1-1/4			

## Ordering Guide

### Type (Select One)

- CS200IN\*\*\*
- CS200IR\*\*\*
- CS205IN\*\*\*
- CS205IR\*\*\*
- CS206IR\*\*\*

### Body Size and End Connection (Select One)

#### Gray Cast Iron

- 3/4 NPT\*\*\*
- 3/4 x 1 NPT\*\*\*
- 3/4 x 1-1/4 NPT\*\*\*
- 1 NPT\*\*\*
- 1 x 1-1/4 NPT\*\*\*
- 1-1/4 NPT\*\*\*

### Outlet Pressure Range (Select One)

- 3.5 to 5 inches w.c. / 9 to 12 mbar, Red\*\*\*
- 4.5 to 6.5 inches w.c. / 11 to 16 mbar, Purple\*\*\*
- 6 to 8 inches w.c. / 5 to 20 mbar, Gold\*\*\*
- 7.5 to 11 inches w.c. / 19 to 27 mbar, Blue\*\*\*
- 10 to 14 inches w.c. / 25 to 35 mbar, Unpainted\*\*\*
- 12 to 19 inches w.c. / 30 to 47 mbar, Green\*\*\*
- 18 inches w.c. to 1 psig / 45 to 69 mbar, Orange\*\*\*
- 1 to 2 psig / 69 to 138 mbar, Black\*\*\*

### Type CS200 Orifice Size (Select One)

- 1/8 inch / 3.2 mm\*\*\*
- 3/16 inch / 4.8 mm\*\*\*
- 1/4 inch / 6.4 mm\*\*\*
- 3/8 inch / 9.5 mm\*\*\*
- 1/2 inch / 13 mm\*\*\*

### Types CS205 and CS206 Secondary Seat™ Orifice Assembly Size (Select One)

- 1/8 inch / 3.2 mm\*\*\*
- 3/16 inch / 4.8 mm\*\*\*
- 1/4 inch / 6.4 mm\*\*\*
- 5/16 inch / 7.9 mm\*\*\*

### Body Orientation (Select One)

- Position 1\*\*\*
- Position 2\*\*\*
- Position 3 (standard)\*\*\*
- Position 4\*\*\*

### Vent Orientation (Select One)

- Position C\*\*\*
- Position D\*\*\*
- Position E\*\*\*
- Position F (standard)\*\*\*

### Certification

#### (Available only on CS200 Series Constructions)

- Pressure Factor Measurement (PFM)

# Bulletin 71.1:CS200

## Ordering Guide (continued)

Regulators Quick Order Guide	
***	Readily Available for Shipment
**	Allow Additional Time for Shipment
*	Special Order, Constructed from Non-Stocked Parts, Consult your local Sales Office for Availability.
Availability of the product being ordered is determined by the component with the longest shipping time for the requested construction.	

Specification Worksheet	
<b>Application:</b>	
Specific Use	_____
Line Size	_____
Gas Type and Specific Gravity	_____
Gas Temperature	_____
Does the Application Require Overpressure Protection?	
<input type="checkbox"/> Yes	<input type="checkbox"/> No
If yes, which is preferred:	
<input type="checkbox"/> Relief Valve	<input type="checkbox"/> Monitor Regulator
<input type="checkbox"/> Shutoff Device	
Is overpressure protection equipment selection assistance desired?	
_____	
<b>Pressure:</b>	
Maximum Inlet Pressure ( $P_{1max}$ )	_____
Minimum Inlet Pressure ( $P_{1min}$ )	_____
Downstream Pressure Setting(s) ( $P_2$ )	_____
Maximum Flow ( $Q_{max}$ )	_____
<b>Performance Required:</b>	
Accuracy Requirements?	_____
Need for Fast Response?	_____
<b>Other Requirements:</b>	
_____	

### Industrial Regulators

#### Emerson Process Management Regulator Technologies, Inc.

USA - Headquarters  
McKinney, Texas 75070 USA  
Tel: +1 800 558 5853  
Outside U.S. +1 972 548 3574

Asia-Pacific  
Shanghai 201206, China  
Tel: +86 21 2892 9000

Europe  
Bologna 40013, Italy  
Tel: +39 051 419 0611

Middle East and Africa  
Dubai, United Arab Emirates  
Tel: +971 4811 8100

### Natural Gas Technologies

#### Emerson Process Management Regulator Technologies, Inc.

USA - Headquarters  
McKinney, Texas 75070 USA  
Tel: +1 800 558 5853  
Outside U.S. +1 972 548 3574

Asia-Pacific  
Singapore 128461, Singapore  
Tel: +65 6770 8337

Europe  
Bologna 40013, Italy  
Tel: +39 051 419 0611  
Chartres 28008, France  
Tel: +33 2 37 33 47 00

### TESCOM

#### Emerson Process Management Tescom Corporation

USA - Headquarters  
Elk River, Minnesota 55330-2445, USA  
Tels: +1 763 241 3238  
+1 800 447 1250

Europe  
Selmsdorf 23923, Germany  
Tel: +49 38823 31 287

Asia-Pacific  
Shanghai 201206, China  
Tel: +86 21 2892 9499



The distinctive swirl pattern cast into every actuator casing uniquely identifies the regulator as part of the Fisher® brand Commercial Service Regulator family and assures you of the highest-quality engineering, performance, and support traditionally associated with Fisher, Tartarini™, and France™ regulators. Visit [www.fishercommercialservice.com](http://www.fishercommercialservice.com) to access interactive applications.

For further information visit [www.emersonprocess.com/regulators](http://www.emersonprocess.com/regulators)

The Emerson logo is a trademark and service mark of Emerson Electric Co. All other marks are the property of their prospective owners. Fisher is a mark owned by Fisher Controls International LLC, a business of Emerson Process Management.

The contents of this publication are presented for informational purposes only, and while every effort has been made to ensure their accuracy, they are not to be construed as warranties or guarantees, express or implied, regarding the products or services described herein or their use or applicability. We reserve the right to modify or improve the designs or specifications of such products at any time without notice.

Emerson Process Management Regulator Technologies, Inc., does not assume responsibility for the selection, use or maintenance of any product. Responsibility for proper selection, use and maintenance of any Emerson Process Management Regulator Technologies, Inc. product remains solely with the purchaser.