

# Types 1098-EGR and 1098H-EGR Pressure Reducing Regulators

- Differential as low as 1 psi / 70 mbar
- Quick Change Trim Package
- No Atmospheric Bleed
- Optional Noise Abatement Trim (Up to 30dBA reduction)
- Easy Top Entry In-Line Maintenance
- Materials of Construction Compatible with Below Grade Installations
- In-Service Travel Inspection
- NPS 1 through 12 x 6 / DN 25 through 300 x 150 Body Sizes Available
- Aqueous Trim Packages (Application Specific)
- Stainless Steel Construction for Corrosive Environments and Oxygen Service



Figure 1. Types 1098-EGR Pressure Reducing Regulator



# Bulletin 71.2:1098-EGR

## Specifications

The Specifications section lists pressure limitations and other specifications for various Types 1098-EGR and 1098H-EGR constructions. Specifications for a given regulator as it originally comes from the factory are stamped on nameplates located on both the actuator and main valve body, while the pilot control spring range is displayed on the pilot spring case and the pilot restriction code is stamped on the pilot body (S = **standard** gain, L = low gain and H = high gain). To determine maximum pressure ratings, the individual ratings for the main valve, actuator and pilot must all be considered.

### Body Sizes and End Connection Styles

See Table 1

### Main Valve Maximum Inlet Pressure<sup>(1)</sup>

400 psig / 27.6 bar or body rating limit whichever is lower

### Maximum Pilot Supply Pressure<sup>(1)(2)</sup>

600 psig / 41.4 bar

### Outlet Pressure Ranges

See Table 2

### Maximum and Minimum Differential Pressures

See Table 4

### Actuator Sizes and Maximum Pressures

See Table 3

### Pressure Registration

External

### Temperature Capabilities<sup>(1)</sup>

**Nitrile (NBR):** -20 to 180°F / -29 to 82°C

**Fluorocarbon (FKM):** 0 to 300°F / -18 to 149°C, except water is limited to 0 to 200°F / -18 to 93°C

**Ethylene propylene (EPR):**  
-20 to 275°F / -29 to 135°C

### Options

- NACE Construction
- Monitor Configuration
- Boiler Fuel Construction
- Aqueous (Liquid) Service Construction
- Noise Abatement Trim

### Port Diameters and Travels

BODY SIZE		PORT DIAMETER		TRAVEL				
				Standard		Restricted		In.
NPS	DN	In.	mm	In.	mm	Percentage of Flow Capacity		
1	25	1-5/16	33.3	3/4	19	----	----	----
2	50	2-3/8	60.3	1-1/8	29	30	3/8	9.5
						70	5/8	16
3	80	3-3/8	85.7	1-1/2	38	40	7/8	22
4	100	4-3/8	111	2	51	40	1	25
6	150	7-3/16	183			----	----	
8 x 6 and 12 x 6	200 x 150 and 300 x 150							

### Construction Materials

#### Main Valve

*Body and Body Flange:* Cast iron, WCC Steel, CF8M Stainless steel

*Cage:* CF8M Stainless steel (Linear), 416 or 316 Stainless steel (Whisper Trim™) or hardened ENC coated Cast iron (Quick Opening)

*Seat Ring and Valve Plug:* Hardened 416 Stainless steel or 316 Stainless steel

*Travel Indicator Assembly:* Steel or Stainless steel except plastic for indicator scale

*Piston Ring:* Polytetrafluoroethylene (PTFE)

*O-rings and Soft Parts:* Nitrile (NBR) (**standard**), Fluorocarbon (FKM) or Ethylene propylene (EPR)

*Spring:* Steel or Inconel® X-750

*Bolting:* Steel, Stainless steel

1. The pressure/temperature limits in this Bulletin or any applicable standard limitation should not be exceeded.

2. For stability or overpressure protection, a reducing regulator may be installed upstream of the pilot according to the Installation section.

- continued -

## Specifications (continued)

### Construction Materials (continued)

#### Actuator

*Bonnet:* Zinc-plated Steel or 304 Stainless steel

*Diaphragm Case:* Steel or Stainless steel

*Bolting:* Steel, Stainless steel

*Diaphragm Plate:* Cast iron, 316 or

WCC Stainless steel

*Stem Guide:* Stainless steel

*Diaphragm and O-rings:* Nitrile (NBR) (**standard**),

Fluorocarbon (FKM), Ethylenepropylene (EPDM)

*Stem:* 17-4 PH Stainless steel (**standard**) or

316 Stainless steel

#### Pilot Mounting Parts

*Tube and Connector Fittings:* Steel (**standard**) or Stainless steel

*Pipe Bushing:* Malleable iron, Stainless steel

*Pipe Nipples:* Galvanized steel, Stainless steel

#### Type 6351 Pilot

*Body, Body Plug and Spring Case:* Aluminum

*Valve Plug Stem:* Brass (**standard**) or Stainless steel

*Diaphragm, O-rings and Gaskets:* Nitrile (NBR)

(**standard**) or Fluorocarbon (FKM)

#### Type 6352, 6353, 6354L, 6354M or 6354H Pilot

*Body, Body Plug, Spring Case and Closing Cap:*

Aluminum (**standard**) or Stainless steel

*Diaphragm:* Nitrile (NBR), Fluorocarbon (FKM) or Ethylenepropylene (EPR)

*Types 6354M and 6354H Diaphragm*

*Limiter:* Aluminum

*O-rings and Soft Parts:* Nitrile (NBR) (**standard**) or Fluorocarbon (FKM)

*Filter:* Brass (Type P594-1 **standard**) or Aluminum (Type P593-1), except cellulose for filter element

#### 61 Series Pilots

*Body and Spring Case:* Cast iron

*Upper and Lower Diaphragm:* Nitrile (NBR),

Neoprene (CR) or Fluorocarbon (FKM)

*Composition Seats:* Nitrile (NBR) or

Fluorocarbon (FKM)

*O-rings:* Nitrile (NBR) or Fluorocarbon (FKM)

#### Type Y600AM Pilot

*Body, Spring Case and Lower Casing:* Cast iron

*Diaphragm:* Nitrile (NBR)

*Composition Seats:* Nitrile (NBR)

*Trim:* Aluminum

#### Pilot and Actuator Vents

Type Y602 vent assembly

### Approximate Weights (With Standard Single-Pilot Construction)

#### Type 1098 Actuator

##### Size 30

*NPS 1 / DN 25 Body:* 55 lbs / 25 kg

*NPS 2 / DN 50 Body:* 75 lbs / 34 kg

*NPS 3 / DN 80 Body:* 115 lbs / 52 kg

*NPS 4 / DN 100 Body:* 165 lbs / 75 kg

*NPS 6 / DN 150 Body:* 350 lbs / 159 kg

*NPS 8 x 6 / DN 200 x 150 Body:* 625 lbs / 284 kg

*NPS 12 x 6 / DN 300 x 150 Body:* 1102 lbs / 500 kg

##### Size 40 (Standard)

*NPS 1 / DN 25 Body:* 65 lbs / 29 kg

*NPS 2 / DN 50 Body:* 85 lbs / 39 kg

*NPS 3 / DN 80 Body:* 125 lbs / 57 kg

*NPS 4 / DN 100 Body:* 175 lbs / 79 kg

*NPS 6 / DN 150 Body:* 360 lbs / 163 kg

*NPS 8 x 6 / DN 200 x 150 Body:* 635 lbs / 288 kg

*NPS 12 x 6 / DN 300 x 150 Body:* 1112 lbs / 504 kg

##### Size 70

*NPS 1 / DN 25 Body:* 140 lbs / 64 kg

*NPS 2 / DN 50 Body:* 160 lbs / 73 kg

*NPS 3 / DN 80 Body:* 200 lbs / 91 kg

*NPS 4 / DN 100 Body:* 250 lbs / 113 kg

*NPS 6 / DN 150 Body:* 435 lbs / 197 kg

*NPS 8 x 6 / DN 200 x 150 Body:* 710 lbs / 322 kg

*NPS 12 x 6 / DN 300 x 150 Body:* 1187 lbs / 538 kg

#### Type 1098H Size 30 Actuator

*NPS 1 / DN 25 Body:* 80 lbs / 36 kg

*NPS 2 / DN 50 Body:* 100 lbs / 45 kg

*NPS 3 / DN 80 Body:* 140 lbs / 64 kg

*NPS 4 / DN 100 Body:* 190 lbs / 86 kg

*NPS 6 / DN 150 Body:* 375 lbs / 170 kg

*NPS 8 x 6 / DN 200 x 150 Body:* 650 lbs / 295 kg

*NPS 12 x 6 / DN 300 x 150 Body:* 1127 lbs / 511 kg

**Table 1. Body Sizes and End Connection Styles**

BODY SIZE		CAST IRON	STEEL OR STAINLESS STEEL
NPS	DN		
1 or 2	25 or 50	NPT, CL125 FF or CL250 RF	NPT, CL150 RF, CL300 RF, CL600 RF, BWE, SWE or PN 16/25/40
3, 4 or 6	80, 100 or 150	CL125 FF or CL250 RF	CL150 RF, CL300 RF, CL600 RF, BWE or PN 16/25/40
8 x 6 or 12 x 6	200 x 150 or 300 x 150	----	CL150 RF, CL300 RF, CL600 RF or BWE

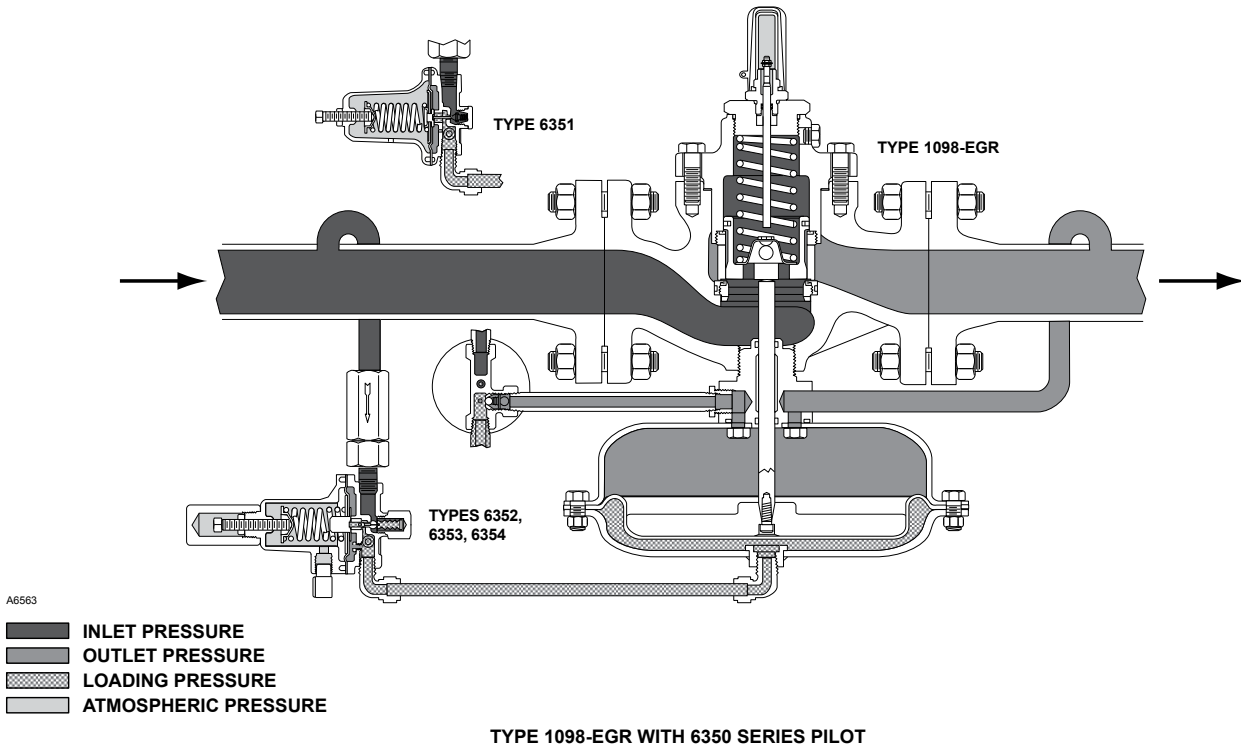

Figure 2. Operational Schematics

## Introduction

The Types 1098-EGR and 1098H-EGR regulators provide economical and accurate pressure control in a wide variety of applications: natural gas distribution systems; fuel gas supply to industrial boilers, furnaces, ovens and mixers; and large commercial/industrial establishments such as shopping centers and schools. They are also used in plant air service and in liquid service where a slow stroking time (approximately 30 to 90 seconds) is desired on both opening and closing the main valve.

The superior performance of this regulator is due to the amplifying effect of the pilot and the two-path control system. Changes in outlet pressure act quickly on the actuator diaphragm to provide fast response to system changes. Then, the pilot amplifies any small system changes to position the main valve for precise pressure control.

Bubble-tight shutoff is achieved utilizing knife-edged seats in the valve plug. When the regulator is in the closed position, the knife-edged seats make a gas-tight seal against the upper and lower (port) valve seal. A variety of cages are offered for standard, speed of response and noise applications. The cage-guided metal plug provides superior control and stability.

## Principle of Operation

The pilot-operated Types 1098-EGR and 1098H-EGR regulators both use inlet pressure as the operating medium, which is reduced through pilot operation to load the actuator diaphragm. Outlet or downstream pressure opposes loading pressure in the actuator and also opposes the pilot control spring. The Type 1098-EGR regulator operation schematic is shown in Figure 2.

In operation, assume that outlet pressure is below the pilot control setting. Control spring force on the pilot diaphragm thus opens the pilot valve plug, providing additional loading pressure to the actuator diaphragm. This loading pressure forces the actuator stem upward, opening the main valve plug via a bump connection. The upward motion of the plug allows gas to flow through the cage into the downstream system.

When downstream demand has been satisfied, outlet pressure tends to increase, acting on the pilot and actuator diaphragms. This pressure exceeds the pilot control spring setting, moving the pilot diaphragm away and letting the valve plug spring (Type 6351, 61 Series or Type Y600AM pilots) or bellows (Types 6352 through 6354M pilots) close the pilot valve plug (unbalanced in the Type 6351 or 61 Series pilots but balanced in the Types 6352 through 6354M pilots). Excess loading

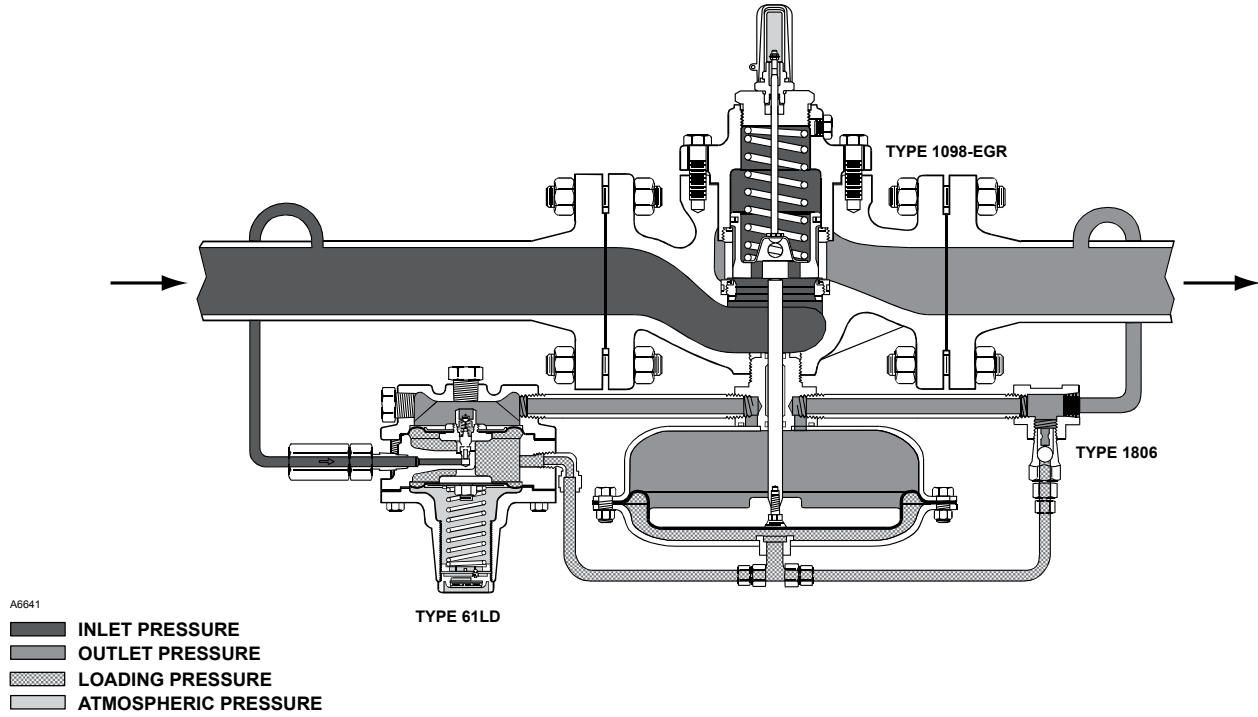

TYPE 1098-EGR WITH TYPE 61LD PILOT

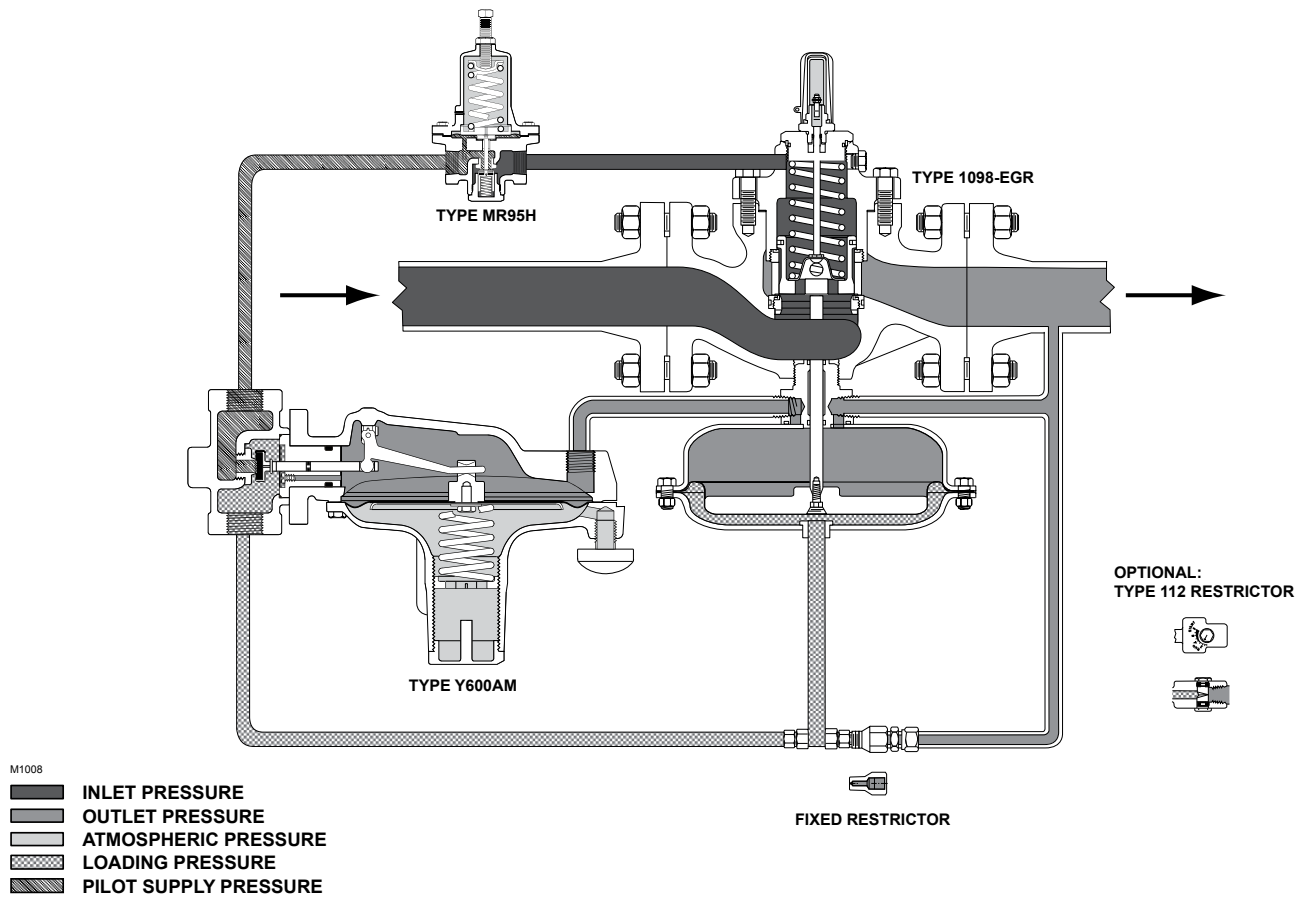

TYPE 1098-EGR WITH TYPE Y600AM PILOT AND TYPE MR95H PRESSURE SUPPLY REGULATOR

Figure 2. Operational Schematics (continued)

# Bulletin 71.2:1098-EGR

---

pressure on the actuator diaphragm escapes downstream through the bleed hole (Type 6351 pilot), bleed orifice (61 Series pilot), restriction (Types 6352 through 6354M pilots) or fixed restrictor (Type Y600AM pilot).

Reduced actuator loading pressure permits the main valve to close. The combination of main valve spring force and valve plug unbalance provides positive valve plug shutoff against the port and upper seals.

To protect the Type 1098 or 1098H actuator diaphragm from excessive differential pressure, the 6350 Series pilots have an integral check valve that allows loading pressure to bleed downstream at approximately 25 psig / 1.7 bar differential across the actuator diaphragm. An external check valve (Type 1806) is required when differential is higher than 25 psid / 1.7 bar d or when using the 61 Series or Type Y600AM pilot.

## Installation

On the Type EGR main valve, normal pressure drop assists shutoff. Therefore, leakage may result during any reverse pressure drop condition. The regulator may be installed in any position. The normal mounting position is with the pilot mounted to the right of the main valve when looking downstream; however, the pilot may be moved to the left side. Control and supply lines necessary for installation are not supplied with the regulator.

In some cases, good piping practice will require that outlet piping be swaged up above the body size to prevent excessive pressure drop along the outlet line. The piping should be as close to the regulator outlet size as possible.

## Construction Features

### Pilots for Application Versatility

The balanced valve plug in the Types 6352, 6353 and 6354 pilots provides fast closing action when quick response is required and also minimizes outlet pressure changes due to varying supply pressures. A tapped spring case with gasketed closing cap is standard for remote venting or for pressure loading applications involving differential pressure control or remote pneumatic adjustment of the downstream pressure setting.

The Type Y600AM and 61 Series pilots provide the option for low setpoints and improved accuracy. The 61 Series pilot is available in a variety of configurations to meet your specific application needs – Type 61L low pressure pilot, Type 61LE low pressure, wide proportional band pilot, Type 61LD low pressure, narrow proportional band pilot and the Type 61H high pressure pilot. These pilots can be configured to maximize the performance under various application scenarios. For instance, the 61 Series pilots are available for fast closing, fast opening or monitor applications. Refer to the 61 Series Pilot Bulletin for specifics.

## Protection from Foreign Material

The standard brass Type P594-1 filter or aluminum Type P593-1 filter in the pilot inlet connection has a replaceable 40-micron cellulose filter element. The Type 252 20-micron filter is recommended for heavy amounts of foreign material in the lines. These filters are described in separate bulletins.

## Noise Abatement Trim

At elevated pressure drops and flow rates regulators with standard trims can produce noise levels that exceed regulatory limits, causing a nuisance for neighbors and even causing mechanical damage to equipment and piping. Whisper Trim™ Cages are available with the Type 1098-EGR to reduce noise by up to 30 dBA.

## Applications

### Low Pressure Gas Distribution Systems

The Type 1098-EGR offers superior performance when utilized to supply low pressure (typically 4 to 12 in. w.c. / 10 to 30 mbar) at district stations operated by gas distribution companies. The two path control system (outlet pressure by control pilot) allows for tight control over the large range of flows typical to district stations. The knife-edged seats in the main valve plug allow for tight shutoff and the cage-guided metal plug aids in stability. Droop can be reduced to a minimum by utilizing an application specific pilot control system, main valve spring and actuator combination (for example, a low droop system would utilize the 95 Series pilot supplying a Type Y600AM control pilot, size 70 actuator, a fixed restrictor or the Type 112 variable restrictor set at 3 and the smallest appropriate main valve spring).

**Table 2. Outlet Pressure Ranges**

PILOT TYPE	OUTLET (CONTROL) PRESSURE RANGE		SPRING COLOR	SPRING PART NUMBER
	psig	bar		
6351	3 to 20	0.2 to 1.4	Green	1B986027212
	5 to 35	0.3 to 2.4	Unpainted	1B788327022
	35 to 100	2.4 to 6.9	Red	1K748527202
6352	14 in. w.c. to 2 psig	35 mbar to 0.1 bar	Yellow	14A9672X012
	2 to 10	0.1 to 0.7	Black	14A9673X012
6353	3 to 40	0.2 to 2.8	Yellow	1E392527022
	35 to 125	2.4 to 8.6	Red	1K748527202
6354L <sup>(1)</sup>	85 to 200	5.9 to 13.8	Blue	1L346127142
6354M <sup>(2)</sup>	175 to 220	12.1 to 15.2	Blue	1L346127142
6354H <sup>(2)</sup>	200 to 300	13.8 to 20.7	Green	15A9258X012
61L	7 in. w.c. to 2 psig	17 mbar to 0.1 bar	Red	1B886327022
	1 to 5	0.07 to 0.3	Yellow	1J857827022
	2 to 10	0.1 to 0.7	Blue	1B886427022
	5 to 15	0.3 to 1.0	Brown	1J857927142
	10 to 20	0.7 to 1.4	Green	1B886527022
61H	10 to 65	0.7 to 4.5	Green Stripe	0Y066427022
61HP	15 to 45	1.0 to 3.1	Yellow	1E392527022
	35 to 100	2.4 to 6.9	Blue	1D387227022
	100 to 300	6.9 to 20.7	Red	1D465127142
Y600AM	4 to 8 in. w.c.	10 to 20 mbar	Red	1B653827052
	7 to 16 in. w.c.	17 to 4 mbar	Unpainted	1B653927022
	15 in. w.c. to 1.2 psig	37 mbar to 0.08 bar	Yellow	1B537027052
	1.2 to 2.5	0.08 to 0.17	Green	1B537127022
	2.5 to 4.5	0.17 to 0.31	Light Blue	1B537227022
	4.5 to 7	0.31 to 0.48	Black	1B537327052

1. Without diaphragm limiter.  
2. With diaphragm limiter.

**Table 3. Actuator Sizes and Maximum Pressures**

ACTUATOR TYPE	ACTUATOR SIZE	OUTLET CONTROL PRESSURE		EMERGENCY CASING PRESSURE	
		psig	bar	psig	bar
1098	30	100	6.9	115	7.9
	40 (standard)	75	5.2	82	5.6
	70	50	3.4	65	4.5
1098H	30	350	24.1	400	27.6

**Table 4. Maximum and Minimum Differential Pressures for Main Valve Selection**

BODY SIZE		SPRING PART NUMBER	SPRING COLOR	MAXIMUM ALLOWABLE DIFFERENTIAL PRESSURE <sup>(1)</sup>		MINIMUM DIFFERENTIAL PRESSURE REQUIRED FOR FULL STROKE					
						Size 30 Actuator		Size 40 Actuator		Size 70 Actuator	
NPS	DN			psig	bar	psig	bar	psig	bar	psig	bar
1	25	14A9687X012	Green	60	4.1	3.5	0.24	2.5	0.17	1	0.07
		14A9680X012	Blue	125	8.6	5	0.34	3	0.21	1.5	0.10
		14A9679X012	Red	400 <sup>(3)</sup>	27.6 <sup>(3)</sup>	7	0.48	5	0.34	2.5	0.17
2	50	14A6768X012	Yellow	20	1.4	----	----	2	0.14	1	0.07
		14A6626X012	Green	60	4.1	4	0.28	3	0.21	1.5	0.10
		14A6627X012	Blue	125	8.6	6	0.41	5	0.34	2	0.14
		14A6628X012	Red	400 <sup>(3)</sup>	27.6 <sup>(3)</sup>	11	0.76	10	0.69	3	0.21
3	80	14A6771X012	Yellow	20	1.4	----	----	2.5	0.17	1	0.07
		14A6629X012	Green	60	4.1	5	0.34	4	0.28	2	0.14
		14A6630X012	Blue	125	8.6	8	0.55	6	0.41	2.5	0.17
		14A6631X012	Red	400 <sup>(3)</sup>	27.6 <sup>(3)</sup>	14	0.97	11	0.76	4	0.28
4	100	14A6770X012	Yellow	20	1.4	----	----	3.5	0.25	1.3	0.09
		14A6632X012	Green	60	4.1	10	0.69	5	0.34	2.5	0.17
		14A6633X012	Blue	125	8.6	13	0.90	8	0.55	3	0.21
		14A6634X012	Red	400 <sup>(3)</sup>	27.6 <sup>(3)</sup>	22	1.5	13	0.90	5	0.34
6, 8 x 6 and 12 x 6	150, 200 x 150 and 300 x 150	15A2253X012	Yellow	20	1.4	----	----	6	0.42	2.2	0.15
		14A9686X012	Green	60	4.1	13	0.90	9.5	0.66	4	0.28
		14A9685X012	Blue	125	8.6	19	1.3	14	0.97	6	0.41
		15A2615X012	Red	400 <sup>(3)</sup>	27.6 <sup>(3)</sup>	28 <sup>(2)</sup>	1.9	19	1.3	8	0.55

1. Maximum inlet pressure is equal to set pressure plus maximum differential.  
2. Requires special 6300 Series pilot construction without integral check valve and with external Type 1806 40 psid / 2.8 bar d check valve.  
3. Should not exceed the body rating limit. Use this pressure value or the body rating limit, whichever is lower.

# Bulletin 71.2:1098-EGR

**Table 5. Recommended Type MR95H Pressure Settings for Use with the Type Y600AM Pilot**

BODY SIZE		TYPE EGR SPRING COLOR	SUPPLY PRESSURE											
			Type Y600AM Spring Color											
NPS	DN		Red	Unpainted		Yellow		Green		Light Blue		Black		
		psig	bar	psig	bar	psig	bar	psig	bar	psig	bar	psig	bar	
1	25	Green	6	0.41	6	0.41	7	0.48	8	0.55	11	0.76	13	0.90
		Blue	7	0.48	7	0.48	8	0.55	10	0.69	13	0.90	14	0.97
		Red	8	0.55	8	0.55	9	0.62	11	0.76	14	0.97	15	1.0
2	50	Green	6	0.41	6	0.41	7	0.48	9	0.62	12	0.83	13	0.90
		Blue	8	0.55	8	0.55	9	0.62	11	0.76	14	0.97	15	1.0
		Red	13	0.90	13	0.90	14	0.97	16	1.1	19	1.3	20	1.4
3	80	Green	7	0.48	7	0.48	8	0.55	10	0.69	13	0.90	14	0.97
		Blue	9	0.62	9	0.62	10	0.69	12	0.83	15	1.0	16	1.1
		Red	14	0.97	14	0.97	15	1.0	17	1.2	20	1.4	21	1.5
4	100	Green	8	0.55	8	0.55	9	0.62	11	0.76	14	0.97	15	1.0
		Blue	11	0.76	11	0.76	12	0.83	14	0.97	17	1.2	18	1.2
		Red	16	1.1	16	1.1	17	1.2	19	1.3	22	1.5	23	1.6
6 or 8 x 6	150 or 200 x 150	Green	13	0.90	13	0.90	14	0.97	15	1.0	18	1.2	20	1.4
		Blue	17	1.2	17	1.2	18	1.2	20	1.4	23	1.6	24	1.7
		Red	22	1.5	22	1.5	23	1.6	25	1.7	28	1.9	29	2.0

1. The pressures shown in the table are the minimum supply pressures required by the pilot. If the inlet pressure is less than shown, an external pilot supply is necessary.

## Monitoring Systems

Monitoring regulators serve as overpressure protection devices to limit system pressure in the event of open failure of a working regulator feeding the system. Two methods of using Type 1098-EGR regulators in monitoring systems are as follows:

### Working Monitor (Figure 3)

On a working monitor installation, the working monitor regulator is always upstream and acts as a first-stage regulator through the working pilot during normal operation. This arrangement allows the working monitor's performance to be observed at all times.

If the second-stage regulator fails to open, the working monitor regulator assumes the entire pressure reduction function of the system via the monitoring pilot. Note that the working monitor regulator actuator must be able to withstand full inlet pressure or be protected from it if the working monitor fails wide-open.

The monitoring pilot must be upstream of the working monitor regulator. This enables a close setpoint between the working regulator and the monitoring pilot. Special Types 161AYW and 627-109 monitoring pilots with quick-bleed operation have been designed to give faster response to abnormal downstream conditions.

Table 6 gives the spread between normal distribution pressure and the minimum pressure at which the working monitor regulator can be set to take over if the working regulator fails open.

### Wide-Open Monitor (Figure 4)

Either the upstream or downstream regulator can be the monitoring regulator. During normal operation, the monitoring regulator is standing wide-open with the reduction to distribution pressure being taken across the working regulator. Only in case of open failure of the working regulator does the wide-open monitoring regulator take control at its slightly higher setting. Note that the outlet pressure rating of the upstream regulator and inlet pressure rating of the downstream regulator must be able to withstand the application's full inlet pressure.

Regardless of which regulator is used as the monitor, it should be equipped with a pilot supply regulator set to 5 psig / 0.34 bar plus the monitor minimum differential pressure above the working regulator pressure setting. Since the pilot on the monitoring regulator is wide-open during normal operation, the pilot supply regulator prevents differential check valve chatter on the monitoring regulator pilot.



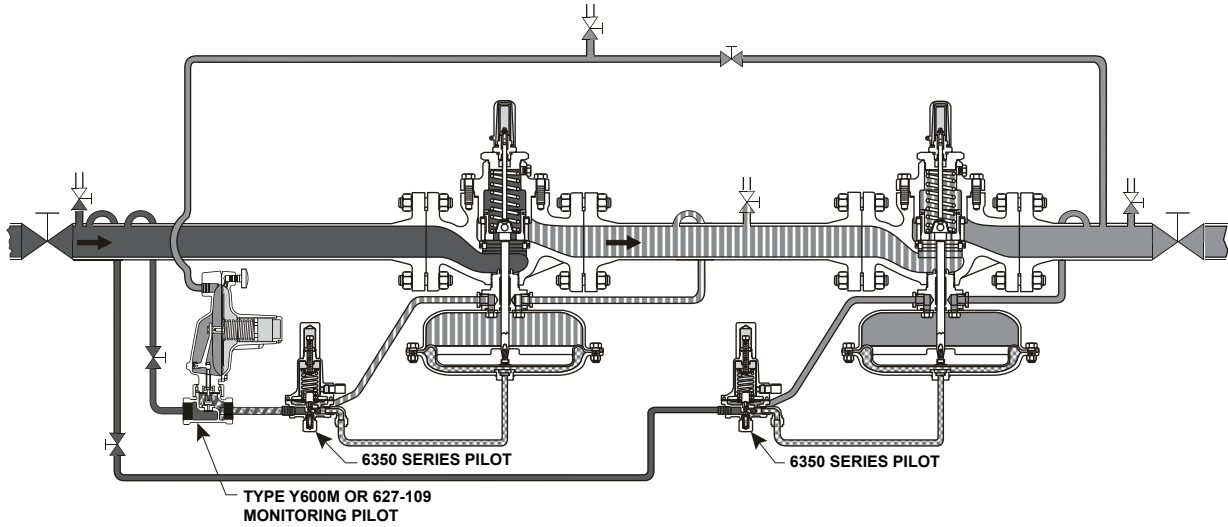

A6788

- INLET PRESSURE
- OUTLET PRESSURE
- ATMOSPHERIC PRESSURE
- LOADING PRESSURE
- INTERMEDIATE PRESSURE

Figure 3. Working Monitor System

Table 6. Working Monitor Performance

Construction	MONITORING PILOT INFORMATION			MINIMUM PRESSURE AT WHICH WORKING MONITOR REGULATOR CAN BE SET
	Spring Range		Spring Part Number	
	psig	bar		
Type 161AYW pilot and 150 psig / 10.3 bar maximum allowable pilot inlet pressure	3 to 12 in. w.c. 11 to 25 in. w.c.	7 to 30 mbar 27 to 62 mbar	1B653927022 1B537027052	3 in. w.c. / 7 mbar over normal distribution pressure
	25 in. w.c. to 2.5 psi 2.5 to 4.5 psi 4.5 to 7 psi	62 mbar to 0.17 bar 0.17 to 0.31 0.31 to 0.4	1B537127022 1B537227022 1B537327052	14 in. w.c. / 34 mbar over normal distribution pressure
Type 627-109 pilot and 1000 psi / 69 bar maximum allowable pilot inlet pressure	5 to 20 15 to 40 35 to 80	0.34 to 1.4 1.0 to 2.8 2.4 to 5.5	10B3076X012 10B3077X012 10B3078X012	3.0 psig / 0.21 bar over normal distribution pressure
	70 to 150 130 to 200	4.8 to 10.3 9.0 to 13.8	10B3079X012	5.0 psig / 0.34 bar over normal distribution pressure

### Adjustment Recommendations for Monitor Applications

Low amplitude/high frequency monitor trim oscillations can occur if the monitor regulator pressure setting is adjusted too closely to the working regulator pressure setting and/or if the monitor pilot supply regulator pressure setting is adjusted too closely to the monitor regulator pressure setting. The monitor pressure

setting should be adjusted so it is at minimum 2 times the pilot proportional band pressure above the working regulator pressure setting. These adjustments must be made such that other governing pressure limits, such as casing ratings, pilot maximum differential pressures or regulatory limits, are not exceeded.

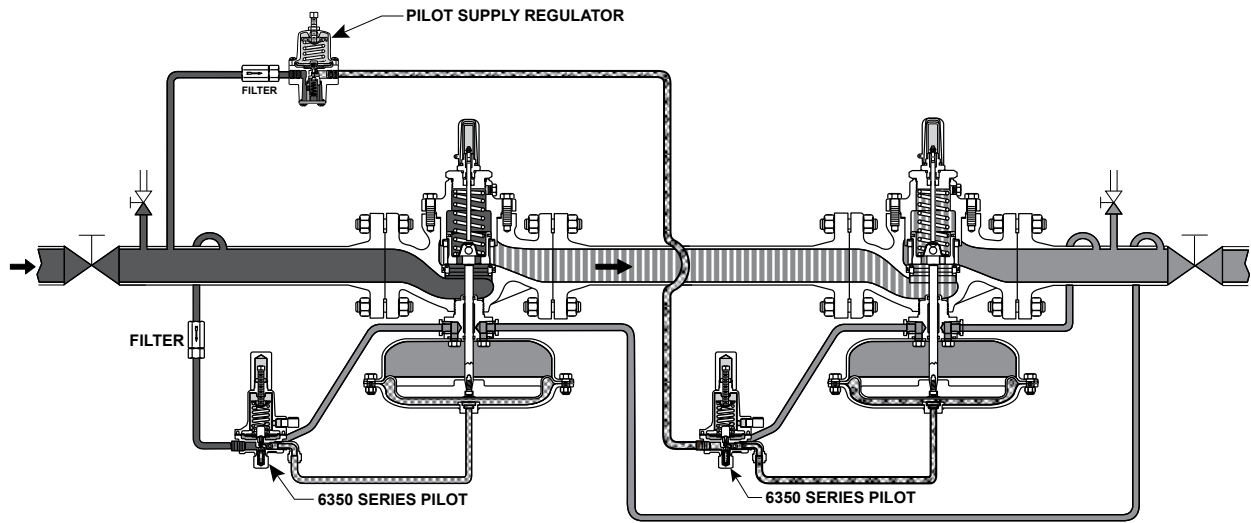

A6789

- INLET PRESSURE
- OUTLET PRESSURE
- LOADING PRESSURE
- PILOT SUPPLY PRESSURE
- ATMOSPHERIC PRESSURE
- INTERMEDIATE PRESSURE

**Figure 4.** Downstream Wide-Open Monitor System

## Boiler Fuel Pressure Control

To enhance proper operation and adequate response to negative pressure shock condition in low differential pressure boiler fuel control applications, use the Type 1098-EGR boiler fuel configuration: Type 1098-EGR with Yellow Main Spring, Quick Opening Cage, Type 6352 pilot, Size 70 Actuator and Type Y600AM or 627M Auxiliary Pilot mounted in parallel with the Type 6352 pilot.

To provide faster response, two pilots mounted in parallel sense the downstream pressure. The Type 6352 pilot is the primary controlling pilot and the Type Y600AM or 627M auxiliary pilot stands by until it senses a negative pressure shock condition. The auxiliary pilot opens, allowing additional flow into the actuator, increasing the stroking speed and providing faster response. See Figure 5 for schematic.

The quick opening cage allows maximum capacity at shorter travels to decrease stroking time in opening and closing directions. The Yellow Main Spring requires that service conditions not exceed 20 psig / 1.4 bar maximum inlet pressure and 10 psi / 0.69 bar maximum differential pressure.

If a pilot light is present, supply it with the Type 1098-EGR. The pilot light gas supply line should branch off the main fuel line downstream of the Type 1098-EGR and include a separate regulator to control the final pilot light gas pressure, if required (see Figures 5 and 6). This allows the Type 1098-EGR to have its main valve plug just off the seat waiting for the sudden negative shock created when the boiler solenoid valve is opened to light the boiler to the high fire load. This configuration significantly increases the stroking speed of the Type 1098-EGR.

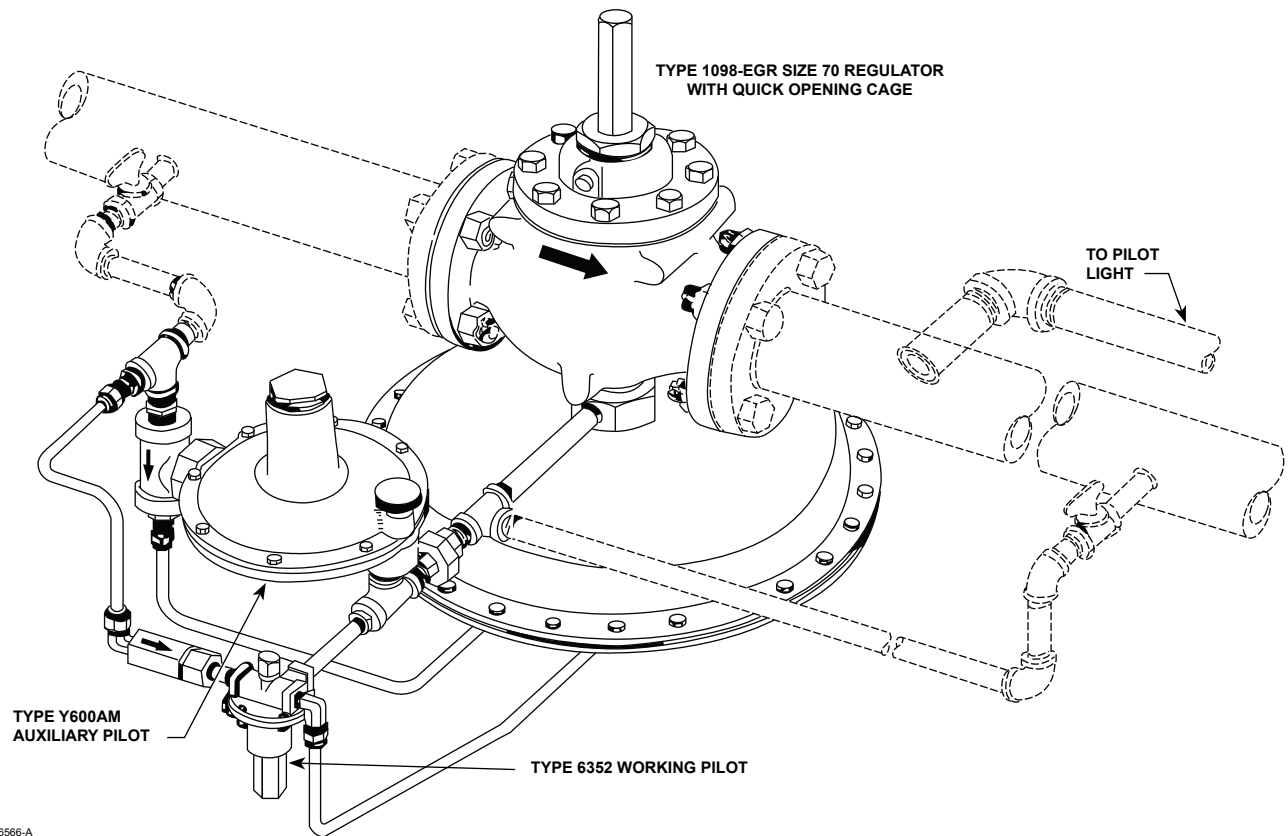

48A6566-A  
B1622

**Figure 5. Boiler Fuel Configuration**

**Table 7. Auxiliary Pilot Selection (Fast Stroke Dual Pilot)**

SIZE	CONSTRUCTION	ORIFICE, In. / mm	SPRING RANGE		SPRING NUMBER	SPRING COLOR	MINIMUM PRESSURE AT WHICH AUXILIARY PILOT CAN BE SET
			psi	bar			
3/4 NPT	Type Y600AM	1/4 / 6.4	4 to 8 in. w.c.	10 to 20 mbar	1B653827052	Red	1 in. w.c. / 2 mbar Under working pilot setpoint
			7 to 16 in. w.c.	17 to 40 mbar	1B653927022	Unpainted	
			15 in. w.c. to 1.2 psi	37 mbar to 0.08 bar	1B537027052	Yellow	
			1.2 to 2.5	0.08 to 0.17	1B537127022	Green	6 in. w.c. / 14 mbar Under working pilot setpoint
			2.5 to 4.5	0.17 to 0.31	1B537227022	Light Blue	
			4.5 to 7	0.31 to 0.48	1B537327052	Black	
	Type 627M		5 to 10	0.34 to 0.69	10B3076X012	Yellow	8 in. w.c. / 21 mbar Under working pilot setpoint

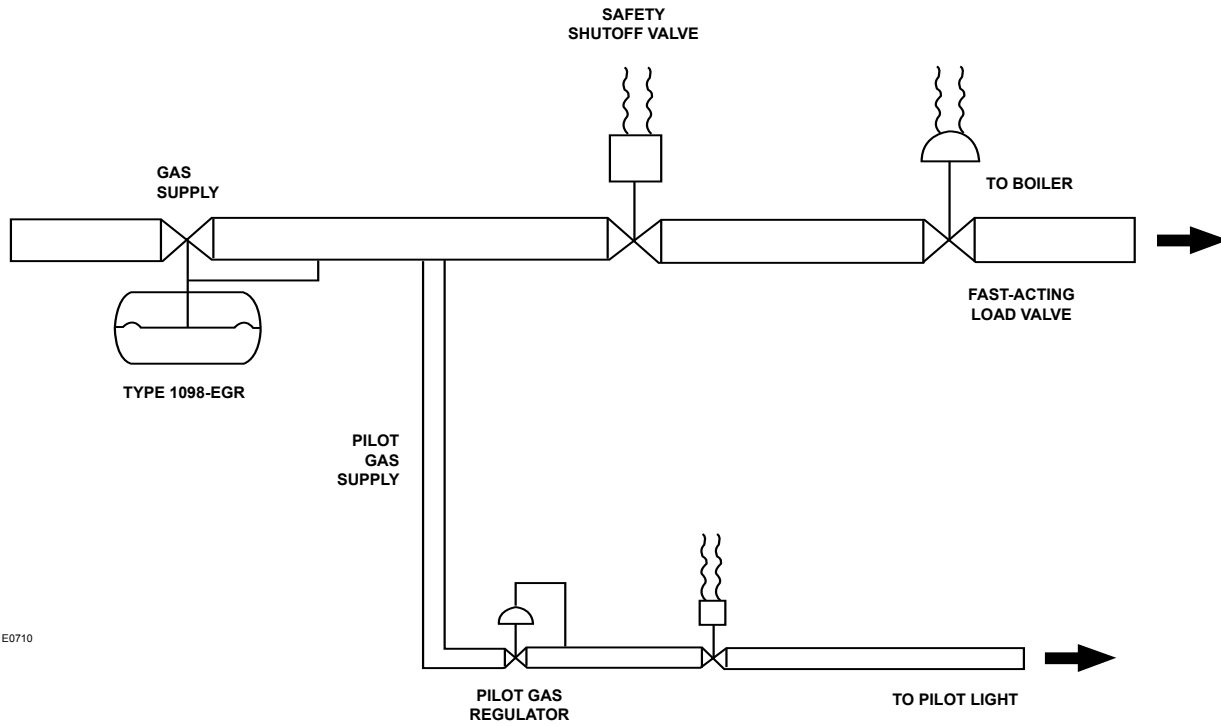

E0710

**Figure 6.** Boiler Fuel Configuration Installation Guide

**Table 8.** Construction Materials for Aqueous Service

AQUEOUS SERVICE TYPE	CONSTRUCTION MATERIAL		
	Cage and Seat Ring	Body Flange	Main Spring
Erosive	416 Stainless steel	CF8M Stainless steel	Inconel® X-750
Corrosive	316 Stainless steel		

1. A low gain pilot should be used on aqueous applications.

## Water Service

When using the Type 1098-EGR in aqueous service, it is important to make the proper material and pilot selections. Table 8 shows proper material selections for erosive or corrosive service. In both cases, a low gain pilot should

be used on any aqueous service to improve the speed of response of the regulator. Follow all general procedures when operating the Type 1098-EGR in aqueous service.

Inconel® is a mark owned by Special Metals Corporation.

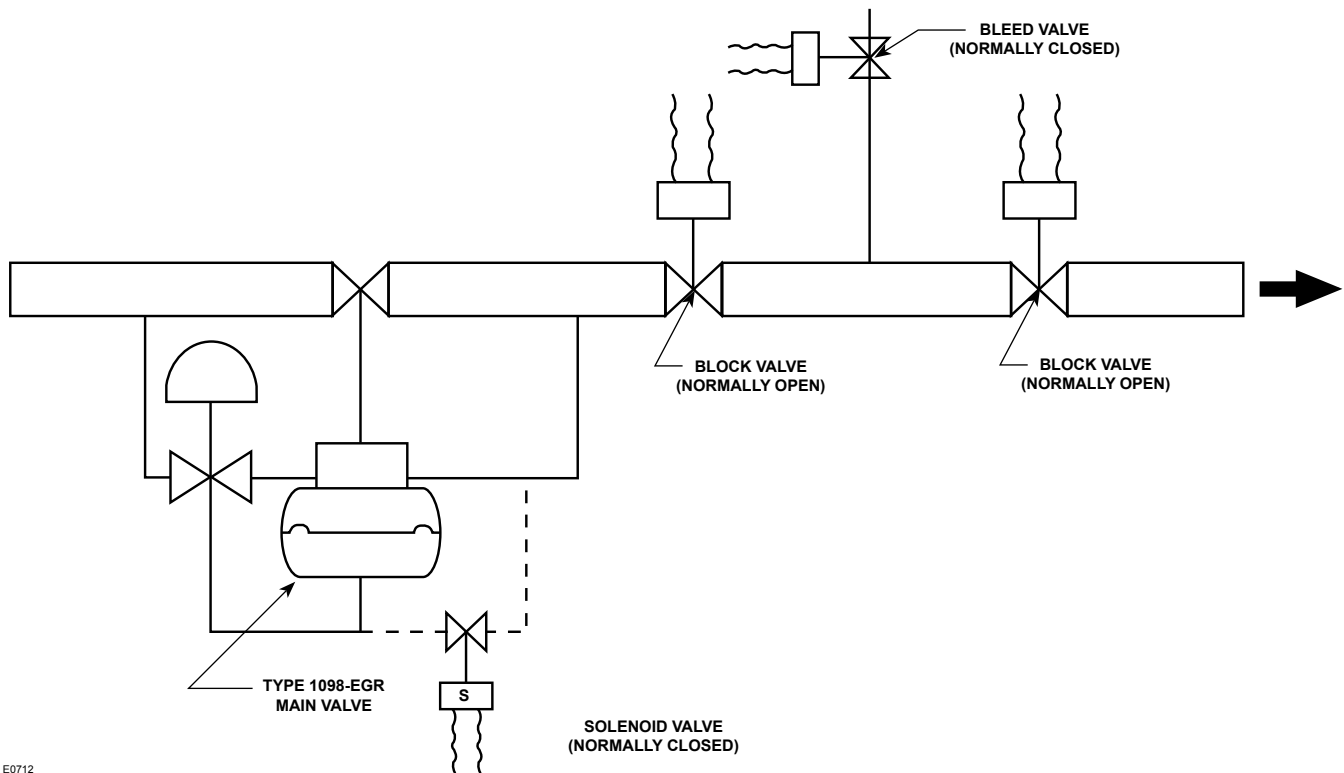

E0712

**Figure 7. Fast-Closing Application Installation Guide**

## Fast Closing Regulator (Figure 7)

When a Type 1098-EGR regulator is used upstream of a double block and bleed system, it is sometimes necessary to modify the Type 1098-EGR control system to increase the closing speed.

A solenoid can be installed as shown in Figure 7. In normal operation, the solenoid valve is closed. The solenoid wiring is connected to the block valve electric logic so that the solenoid on the regulator opens when the block valve is closed.

This concept will quickly equalize pressure on both sides of the Type 1098 diaphragm and allow quick closure. In some systems, the Type 1098-EGR will close faster than the block valve as evidenced by a momentary decline in the Type 1098-EGR outlet pressure. The pressure is then promptly restored back to a setpoint by flow through the pilot only (i.e., the main valve is unable to open because of the solenoid valve).

## Capacity Information

### Note

**Flow capacities are laboratory verified; therefore, regulators may be sized for 100% of the published flow capacities. It is not necessary to reduce published capacities.**

### Gases

Table 11 shows the natural gas regulating capacities of the Type 1098-EGR at selected inlet and outlet pressure settings. Flows are in thousands of SCFH at 60°F and 14.7 psia and in thousands of Nm<sup>3</sup>/h at 0°C and 1.01325 bar of 0.6 specific gravity natural gas.

To determine equivalent capacities for air, propane, butane or nitrogen, multiply the capacity by the following appropriate conversion factor: 0.775 for air, 0.628 for propane, 0.548 for butane or 0.789 for nitrogen. For gases of other specific gravities, multiply the given capacity by 0.775 and divide by the square root of the appropriate specific gravity.

To find appropriate regulating capacities at pressure settings not given in Table 11 or to find wide-open flow capacities for relief sizing at any inlet pressure, perform one of the following procedures. Then, if necessary, convert using the factors provided above.

For critical pressure drops (absolute outlet pressure equal to or less than one-half of absolute inlet pressure), use the following formula:

$$Q = (P_1)(C_g)(1.29)$$

where,

Q = gas flow rate, SCFH

P<sub>1</sub> = absolute inlet pressure, psia (P<sub>1</sub> gauge + 14.7)

C<sub>g</sub> = regulating or wide-open gas sizing coefficient from Table 13, 14 or 15

Then, if capacity is desired in normal cubic meters per hour at 0°C and 1.01325 bar, multiply SCFH by 0.0268.

For pressure drops lower than critical (absolute outlet pressure greater than one-half of absolute inlet pressure).

$$Q = \sqrt{\frac{520}{GT}} C_g P_1 \text{SIN} \left( \frac{3417}{C_1} \sqrt{\frac{\Delta P}{P_1}} \right) \text{DEG}$$

where,

Q = gas flow rate, SCFH

G = gas specific gravity of the gas

T = absolute temperature of gas at inlet, °Rankine

C<sub>g</sub> = gas sizing coefficient

P<sub>1</sub> = absolute inlet pressure, psia  
(P<sub>1</sub> gauge + 14.7)

C<sub>1</sub> = flow coefficient

ΔP = pressure drop across the regulator, psi

Then, if capacity is desired in normal cubic meters per hour (Nm<sup>3</sup>/h) at 0°C and 1.01325 bar, multiply SCFH by 0.0268.

### Liquids

The liquid capacities in Table 12 are in gallons per minute and liters per minute of water. To determine flow capacity not given, use the following equation:

$$Q = C_v \sqrt{\frac{\Delta P}{G}}$$

where,

Q = liquid flow rate, GPM

C<sub>v</sub> = liquid sizing coefficient

ΔP = pressure drop across the regulator, psi

G = specific gravity (specific gravity of water is 1)

If capacity is desired in liters per minute, multiply gallons per minute by 3.785. Use the K<sub>m</sub> values to predict choked flow on aqueous service.

**Table 9. Proportional Band (Standard Pilot Restriction and Size 40 Type 1098 Actuator<sup>(1)</sup>)**

BODY SIZE		PILOT		PROPORTIONAL BAND					
		Type	Control Spring Color	Yellow or Green Main Valve Spring		Blue Main Valve Spring		Red Main Valve Spring	
NPS	DN			psi	mbar	psi	mbar	psi	mbar
1	25	6351	Green	0.10	7	0.20	14	0.40	28
			Unpainted	0.20	14	0.40	28	0.80	55
			Red	0.40	28	0.80	55	1	69
		6352	Yellow	0.04	3	0.10	7	0.20	14
			Black	0.08	6	0.20	14	0.40	28
		6353	Yellow	0.20	14	0.40	28	0.80	55
			Red	0.40	28	0.80	55	1	69
		61L	All	0.09	6	0.16	11	0.30	21
		61LD		0.04	3	0.08	6	0.20	14
		61LE, 61H and 61HP		0.40	28	0.80	55	1	69
		Y600AM <sup>(2)</sup>	Red	0.01	0.6	0.02	1	0.04	3
			Unpainted	0.01	0.6	0.02	1	0.04	3
			Yellow	0.05	3	0.10	7	0.15	10
			Green	0.10	7	0.15	10	0.20	14
Light Blue	0.15		10	0.20	14	0.25	17		
Black	0.20		14	0.25	17	0.30	21		
2	50	6351	Green	0.20	14	0.30	21	0.50	34
			Unpainted	0.30	21	0.50	34	1	69
			Red	0.50	34	1	69	1.40	97
		6352	Yellow	0.05	3	0.15	10	0.30	21
			Black	0.10	7	0.30	21	0.60	41
		6353	Yellow	0.30	21	0.50	34	1	69
			Red	0.50	34	1	69	1.40	97
		61L	All	0.10	7	0.20	14	0.60	41
		61LD		0.05	3	0.10	7	0.30	21
		61LE, 61H and 61HP		0.50	34	1	69	1.40	97
		Y600AM <sup>(2)</sup>	Red	0.01	0.6	0.02	1	0.04	3
			Unpainted	0.01	0.6	0.02	1	0.04	3
			Yellow	0.05	4	0.10	7	0.15	10
			Green	0.10	7	0.15	10	0.20	14
Light Blue	0.15		10	0.20	14	0.25	17		
Black	0.20		14	0.25	17	0.30	21		
3	80	6351	Green	0.30	21	0.40	28	0.60	41
			Unpainted	0.40	28	0.60	41	1.20	83
			Red	0.90	62	1.20	83	1.50	103
		6352	Yellow	0.10	7	0.20	14	0.40	27.6
			Black	0.20	14	0.40	28	0.80	55.2
		6353	Yellow	0.40	28	0.60	41	1.20	82.8
			Red	0.90	62	1.20	83	1.50	103
		61L	All	0.20	14	0.40	28	1	69.0
		61LD		0.10	7	0.20	14	0.50	34.5
		61LE, 61H and 61HP		0.90	62	1.20	83	1.50	103
		Y600AM <sup>(2)</sup>	Red	0.01	0.6	0.02	1	0.04	3
			Unpainted	0.01	0.6	0.02	1	0.04	3
			Yellow	0.05	4	0.10	7	0.15	10
			Light Green	0.10	7	0.15	10	0.20	14
Light Blue	0.15		10	0.20	14	0.25	17		
Black	0.20		14	0.25	17	0.30	21		

1. For other combinations, multiply table values by 1.6 for a size 30 actuator, 0.4 for a size 70 actuator, 2.0 for a low-gain Type 6352 or 6353 pilot restriction and 0.5 for a high-gain Type 6352 or 6353 pilot restriction. For instance, a standard NPS 2 / DN 50 Type 1098-EGR-6352 regulator with black pilot control spring and blue main valve spring has a proportional band of 0.3 psi / 0.021 bar as given in the table, but this same regulator with low-gain restriction and size 70 actuator has a proportional band of 0.3 psi / 0.021 bar x 2.0 x 0.4 = 0.24 psi / 0.017 bar.

2. The configuration utilized in determining the proportional band of the Type Y600AM included the 95 Series pilot supplying the Type Y600AM for improved stability and a fixed restrictor, part number 1K9484X0022 or an optional Type 112 variable restrictor with a setting of 3.

- continued -

# Bulletin 71.2:1098-EGR

**Table 9. Proportional Band (Standard Pilot Restriction and Size 40 Type 1098 Actuator<sup>(1)</sup>) (continued)**

BODY SIZE		PILOT		PROPORTIONAL BAND					
		Type	Control Spring Color	Yellow or Green Main Valve Spring		Blue Main Valve Spring		Red Main Valve Spring	
NPS	DN			psi	mbar	psi	mbar	psi	mbar
4	100	6351	Green	0.40	28	0.50	34	0.80	55
			Unpainted	0.70	48	0.80	55	1.40	97
			Red	1.20	83	2.00	138	3.00	207
		6352	Yellow	0.15	10	0.30	21	0.60	41
			Black	0.30	21	0.60	41	1.20	83
		6353	Yellow	0.70	48	0.80	55	1.40	97
			Red	1.20	83	2.00	138	3.00	207
		61L	All	0.30	21	0.60	41	1.40	97
		61LD		0.15	10	0.30	21	0.70	48
		61LE, 61H and 61HP		1.20	83	2.00	138	3.00	207
		Y600AM <sup>(2)</sup>	Red	0.01	0.6	0.02	1	0.04	3
			Unpainted	0.01	0.6	0.02	1	0.04	3
			Yellow	0.05	3	0.10	7	0.15	10
			Green	0.10	7	0.15	10	0.20	14
			Light Blue	0.15	10	0.20	14	0.25	17
			Black	0.20	14	0.25	17	0.30	21
		6, 8 x 6 and 12 x 6	150, 200 x 150 and 300 x 150	6351	Green	0.50	34	0.60	41
Unpainted	0.90				62	1.50	103	2.00	138
Red	1.50				103	2.50	172	3.50	241
6352	Yellow			0.20	14	0.40	28	0.80	55
	Black			0.40	28	0.80	55	1.60	110
6353	Yellow			0.90	62	1.50	103	2.00	138
	Red			1.50	103	2.50	172	3.50	241
61L	All			0.60	41	1.20	83	2.00	138
61LD				0.30	21	0.60	41	2.00	69
61LE, 61H and 61HP				1.50	103	2.50	172	3.50	241
Y600AM <sup>(2)</sup>	Red			0.01	0.6	0.02	1	0.04	3
	Unpainted			0.01	0.6	0.02	1	0.04	3
	Yellow			0.05	3	0.10	7	0.15	10
	Green			0.05	3	0.15	10	0.20	14
	Light Blue			0.15	10	0.20	14	0.25	17
	Black			0.20	14	0.25	17	0.30	21

1. For other combinations, multiply table values by 1.6 for a size 30 actuator, 0.4 for a size 70 actuator, 2.0 for a low-gain Type 6352 or 6353 pilot restriction and 0.5 for a high-gain Type 6352 or 6353 pilot restriction. For instance, a standard NPS 2 / DN 50 Type 1098-EGR-6352 regulator with black pilot control spring and blue main valve spring has a proportional band of 0.3 psi / 0.021 bar as given in the table, but this same regulator with low-gain restriction and size 70 actuator has a proportional band of 0.3 psi / 0.021 bar x 2.0 x 0.4 = 0.24 psi / 0.017 bar.

2. The configuration utilized in determining the proportional band of the Type Y600AM included the 95 Series pilot supplying the Type Y600AM for improved stability and a fixed restrictor, part number 1K9484X0022 or an optional Type 112 variable restrictor with a setting of 3.

**Table 10. Approximate Proportional Band Range (Standard Pilot Restriction, Size 30 Type 1098H Actuator<sup>(1)</sup>)**

BODY SIZE		PILOT		APPROXIMATE PROPORTIONAL BAND RANGE					
		Type	Control Spring Color	Green Main Valve Spring		Blue Main Valve Spring		Red Main Valve Spring	
NPS	DN			psi	bar	psi	bar	psi	bar
1	25	6354L, 6354M or 6354H	Blue or Green	1	0.07	1.5	0.10	2.5	0.17
2	50			1.5	0.10	2.0	0.14	3.0	0.21
3	80			2.5	0.17	3.0	0.21	4.0	0.28
4	100			3.5	0.24	4.0	0.28	5.0	0.34
6, 8 x 6 or 12 x 6	150, 200 x 150 or 300 x 150			4	0.28	5.0	0.34	Not Available	

1. For other restrictions, multiply table values by 2.0 for a low-gain restriction or by 0.5 for a high-gain restriction. For instance, a standard NPS 2 / DN 50 Type 1098H-EGR-6354L regulator with blue control spring and blue main valve spring has a proportional band of 2.0 psi / 0.14 bar as given in the table. But this same regulator with low-gain restriction has a proportional band of 2.0 psi / 0.14 bar x 2.0 = 4.0 psi / 0.28 bar.



**Table 11. Natural Gas Capacities**

INLET PRESSURE		OUTLET PRESSURE SETTING		CAPACITIES IN THOUSANDS OF SCFH / Nm <sup>3</sup> /h OF 0.6 SPECIFIC GRAVITY NATURAL GAS FOR REGULATORS WITH STANDARD LINEAR CAGE, STANDARD TRAVEL AND LINE SIZE EQUALS MAIN VALVE BODY SIZE													
				NPS 1 / DN 25 Body Size		NPS 2 / DN 50 Body Size		NPS 3 / DN 80 Body Size		NPS 4 / DN 100 Body Size		NPS 6 / DN 150 Body Size		NPS 8 x 6 / DN 200 x 150 Body Size		NPS 12 x 6 / DN 300 x 150 Body Size	
psig	bar	psig	bar	SCFH	Nm <sup>3</sup> /h	SCFH	Nm <sup>3</sup> /h	SCFH	Nm <sup>3</sup> /h	SCFH	Nm <sup>3</sup> /h	SCFH	Nm <sup>3</sup> /h	SCFH	Nm <sup>3</sup> /h	SCFH	Nm <sup>3</sup> /h
3	0.21	7 in. w.c.	17 mbar	8	0.2	32	0.9	66	1.8	101	2.7	----	----	----	----	----	----
5	0.34	7 in. w.c.	17 mbar	11	0.3	42	1.1	87	2.3	135	3.6	257	6.9	372	10.0	427	11.4
		1	0.07	10	0.3	39	1.0	82	2.2	126	3.4	241	6.5	350	9.4	401	10.7
		2	0.1	9	0.2	35	0.9	73	2.0	112	3.0	----	----	----	----	----	----
10	0.69	7 in. w.c.	17 mbar	17	0.5	63	1.7	129	3.5	201	5.4	376	10.1	542	14.5	622	16.7
		3	0.2	15	0.4	56	1.5	116	3.1	180	4.8	341	9.1	493	13.2	565	15.1
		5	0.3	13	0.4	49	1.3	102	2.7	158	4.2	302	8.1	438	11.7	502	13.5
		7	0.5	11	0.3	40	1.1	82	2.2	127	3.4	----	----	----	----	----	----
15	1.0	1	0.07	21	0.6	79	2.1	163	4.4	254	6.8	471	12.6	678	18.2	777	20.8
		4	0.3	20	0.5	74	2.0	153	4.1	237	6.4	445	11.9	642	17.2	735	19.7
		8	0.5	17	0.5	63	1.7	130	3.5	201	5.4	385	10.3	557	14.9	638	17.1
		12	0.8	12	0.3	44	1.2	91	2.4	140	3.8	----	----	----	----	----	----
20	1.4	1	0.07	27	0.7	102	2.7	207	5.6	328	8.8	577	15.5	827	22.1	948	25.4
		10	0.7	21	0.6	79	2.1	164	4.4	254	6.8	482	12.9	696	18.7	798	21.4
		15	1.0	16	0.4	60	1.6	125	3.4	192	5.2	371	9.9	538	14.4	616	16.5
		17	1.2	13	0.4	48	1.3	99	2.7	153	4.1	----	----	----	----	----	----
30	2.1	4	0.3 or less	35	0.9	131	3.5	267	7.2	422	11.3	744	19.9	1066	28.6	1221	32.7
		15	1.0	29	0.8	108	2.9	223	6.0	345	9.3	651	17.5	940	25.2	1077	28.9
		20	1.4	25	0.7	93	2.5	192	5.2	297	8.0	568	15.2	822	22.0	942	25.2
		25	1.7	18	0.5	69	1.6	144	3.9	221	5.9	429	11.5	622	16.7	713	19.1
40	2.8	9	0.6 or less	42	1.1	161	4.3	327	8.8	517	13.9	910	24.4	1304	34.9	1495	40.1
		20	1.4	36	1.0	136	3.6	280	7.5	434	11.6	816	21.9	1178	31.6	1350	36.2
		30	2.1	28	0.8	105	2.8	217	5.8	335	9.0	644	17.3	933	25.0	1069	28.6
		35	2.4	21	0.6	77	2.1	161	4.3	247	6.6	480	12.9	697	18.7	798	21.4
50	3.4	13	0.9 or less	50	1.3	190	5.1	386	10.3	611	16.4	1077	28.9	1542	41.3	1768	47.4
		20	1.4	45	1.2	172	4.6	354	9.5	551	14.8	1023	27.4	1473	39.5	1688	45.2
		30	2.1	40	1.1	152	4.1	313	8.4	485	13.0	919	24.6	1327	35.6	1521	40.8
		40	2.8	31	0.8	115	3.1	240	6.4	369	9.9	712	19.1	1032	27.7	1182	31.7
75	5.2	45	3.1	22	0.6	85	2.3	176	4.7	270	7.24	526	14.1	764	20.5	875	23.5
		24	1.6 or less	69	1.9	264	7.1	536	14.4	847	22.7	1493	40.0	2138	57.3	2451	65.7
		50	3.4	54	1.5	203	5.4	419	11.2	648	17.4	1232	33.0	1781	47.7	2041	54.7
		60	4.1	44	1.2	166	4.5	343	9.2	529	14.2	1019	27.3	1476	39.6	1692	45.3
100	6.9	70	4.8	27	0.7	101	2.7	209	5.6	322	8.63	627	16.8	911	24.4	1044	28.0
		35	2.4 or less	89	2.4	337	9.0	685	18.4	1083	29.0	1909	51.2	2734	73.2	3134	84.0
		60	4.1	74	2.0	280	7.5	578	15.5	896	24.0	1689	45.3	2438	65.3	2794	74.9
		75	5.2	62	1.7	236	6.3	489	13.1	754	20.2	1444	38.7	2090	56.0	2396	64.2
125	8.6	46	3.2 or less	108	2.9	411	11.0	834	22.4	1319	35.3	2325	62.3	3330	89.2	3817	102
		75	5.2	91	2.4	344	9.2	710	19.0	1101	29.5	2072	55.5	2990	80.1	3427	91.8
150	10.3	57	3.9 or less	127	3.4	484	13.0	984	26.4	1555	41.7	2741	73.5	3926	105	4500	121
		75	5.2	115	3.1	436	11.7	897	24.0	1396	37.4	2593	69.5	3735	100	4281	115
175	12.1	68	4.7 or less	147	3.9	558	15.0	1133	30.4	1791	48.0	3157	84.6	4522	121	5183	139
200	13.8	75	5.2 or less	166	4.5	631	16.9	1282	34.4	2027	54.3	3573	95.8	5118	137	5866	157
250	17.2			205	5.5	779	20.9	1581	42.4	2500	67.0	4405	118	6310	169	7232	194
300	20.7			244	6.5	926	24.8	1880	50.4	2972	79.6	5237	140	7502	201	8598	230
350	24.1			282	7.6	1073	28.8	2178	58.4	3444	92.3	6069	163	8694	234	9964	267
400	27.6			321	8.6	1220	32.7	2477	66.4	3916	105	6901	185	9886	265	11,331	304

# Bulletin 71.2:1098-EGR

Table 12. Liquid Capacities

INLET PRESSURE		OUTLET PRESSURE SETTING		CAPACITIES IN GPM / l/min OF WATER FOR REGULATORS WITH STAINLESS STEEL LINEAR HOLE CAGE													
				NPS 1 / DN 25 Body Size		NPS 2 / DN 50 Body Size		NPS 3 / DN 80 Body Size		NPS 4 / DN 100 Body Size		NPS 6 / DN 150 Body Size		NPS 8 x 6 / DN 200 x 150 Body Size		NPS 12 x 6 / DN 300 x 150 Body Size	
psig	bar	psig	bar	GPM	l/min	GPM	l/min	GPM	l/min	GPM	l/min	GPM	l/min	GPM	l/min	GPM	l/min
3	0.21	0.25	0.02	28	106	105	397	219	829	335	1268	658	2491	959	3630	1098	4156
5	0.34	0.25	0.02	37	140	138	522	288	1090	440	1665	865	3274	1260	4769	1443	5462
		1	0.07	34	129	127	481	264	999	404	1529	794	3005	1156	4375	1324	5011
		2	0.1	29	110	110	416	229	867	350	1325	688	2604	1001	3789	1147	4342
10	0.69	0.25	0.02	52	197	198	749	412	1559	631	2388	1240	4693	1805	8632	2067	7824
		3	0.2	44	167	167	632	349	1321	534	2021	1050	3974	1529	5787	1751	6628
		5	0.3	38	144	142	537	295	1117	452	1711	888	3361	1292	4890	1480	5602
		7	0.5	29	110	110	416	229	867	350	1325	688	2604	1001	3789	1147	4341
15	1.0	1	0.07	63	238	237	897	494	1870	756	2861	1485	5621	2163	8187	2477	9375
		4	0.3	56	212	210	795	438	1658	670	2536	1317	4985	1917	7256	2196	8312
		8	0.5	44	167	167	632	349	1321	534	2021	1050	3974	1529	5787	1751	6628
		12	0.8	29	110	110	416	229	867	350	1325	688	2604	1001	3789	1147	4341
20	1.4	1	0.07	73	276	276	1045	575	2176	880	3331	1730	6548	2519	9534	2886	10,924
		10	0.7	53	201	200	757	417	1578	639	2419	1255	4750	1828	6919	2093	7922
		15	1.0	38	144	142	537	295	1117	452	1711	888	3361	1292	4890	1480	5602
		17	1.2	29	110	110	416	229	867	350	1325	688	2604	1001	3789	1147	4341
30	2.1	4	0.3 or less	86	326	323	1223	673	2547	1030	3899	2024	7661	2947	11,154	3376	12,778
		15	1.0	65	246	245	927	511	1934	782	2960	1538	5821	2239	8475	2564	9705
		20	1.4	53	201	200	757	417	1578	639	2419	1255	4750	1828	6919	2093	7922
		25	1.7	38	144	142	537	295	1117	452	1711	888	3361	1292	4890	1480	5602
40	2.8	9	0.6 or less	94	356	352	1332	735	2782	1125	4258	2210	8365	3218	12,180	3686	13,952
		20	1.4	75	284	283	1071	590	2233	903	3418	1775	6718	2585	9784	2961	11,207
		30	2.1	53	201	200	757	417	1578	639	2419	1255	4750	1828	6919	2093	7922
		35	2.4	38	144	142	537	295	1117	452	1711	888	3361	1292	4890	1480	5602
50	3.4	13	0.9 or less	102	386	385	1457	803	3039	1229	4652	2415	9141	3516	13,308	4027	15,242
		20	1.4	92	348	347	1313	723	2737	1106	4186	2174	8229	3166	11,983	3626	13,724
		30	2.1	75	284	283	1071	590	2233	903	3418	1775	6718	2585	9784	2961	11,207
		40	2.8	53	201	200	757	417	1578	639	2419	1255	4750	1828	6919	2093	7922
75	5.2	45	3.1	38	144	142	537	295	1117	452	1711	888	3361	1292	4890	1480	5602
		24	1.6 or less	120	454	452	1711	943	3569	1443	5462	2835	10,730	4128	15,624	4728	17,895
		50	3.4	84	318	317	1200	660	2498	1010	3823	1985	7513	2890	10,939	3310	12,528
		60	4.1	65	246	245	927	511	1934	782	2960	1538	5821	2239	8475	2564	9705
100	6.9	70	4.8	38	144	142	537	295	1117	452	1711	888	3361	1292	4890	1480	5602
		35	2.4 or less	135	511	510	1930	1064	4027	1629	6166	3201	12,116	4660	17,638	5337	20,201
		60	4.1	106	401	400	1514	835	3160	1278	4837	2511	9504	3656	13,837	4187	15,848
		75	5.2	84	318	317	1200	660	2498	1010	3823	1985	7513	2890	10,939	3310	12,528
125	8.6	46	3.2 or less	149	564	563	2131	1173	4440	1795	6794	3529	13,357	5137	19,444	5884	22,271
		75	5.2	119	450	448	1696	933	3531	1428	5405	2807	10,624	4087	15,469	4681	17,718
150	10.3	57	3.9 or less	162	613	610	2309	1273	4818	1948	7373	3829	14,493	5574	21,098	6384	24,163
		75	5.2	145	549	548	2074	1143	4326	1749	6620	3438	13,013	5006	18,948	5733	21,699
175	12.1	68	4.7 or less	174	659	655	2479	1365	5167	2090	7911	4107	15,545	5979	22,630	6848	25,920
200	13.8	75	5.2 or less	188	712	708	2680	1476	5587	2258	8547	4439	16,802	6462	24,459	7401	28,013
250	17.2			222	840	837	3168	1746	6609	2672	10,114	5252	19,879	7646	28,940	8757	33,145
300	20.7			252	954	950	3596	1980	7494	3030	11,469	5955	22,540	8670	32,816	9930	37,585
350	24.1			279	1056	1050	3974	2189	8285	3350	12,680	6584	24,920	9585	36,279	10,978	41,552
400	27.6			303	1147	1141	4319	2380	9008	3642	13,785	7157	27,089	10,420	39,440	11,934	45,170

**Table 13. Flow Coefficients for Type 1098-EGR with Linear Cage**

BODY SIZE		1:1 LINE SIZE TO BODY SIZE					2:1 LINE SIZE TO BODY SIZE					K <sub>m</sub>	IEC SIZING COEFFICIENT		
		C <sub>g</sub>		C <sub>v</sub>		C <sub>1</sub>	C <sub>g</sub>		C <sub>v</sub>		C <sub>1</sub>		X <sub>T</sub>	F <sub>D</sub>	F <sub>L</sub>
NPS	DN	Regulating	Wide-Open	Regulating	Wide-Open		Regulating	Wide-Open	Regulating	Wide-Open		C <sub>1</sub>			
1	25	600	632	16.8	17.7	35.7	568	598	17.2	18.1	33.0	0.70	0.806	0.43	0.84
2	50	2280	2400	63.3	66.7	36.0	2050	2160	59.6	62.8	34.4		0.820	0.35	
3	80	4630	4880	132	139	35.1	4410	4650	128	135	35.0		0.779	0.30	
4	100	7320	7710	202	213	36.2	6940	7310	198	209	35.0		0.829	0.28	
6	150	12,900	13,600	397	418	32.5	12,100	12,800	381	404	31.7		0.668		
8 x 6	200 x 150	18,480	19,450	578	608	32.0	17,370	18,280	543	571	32.0		0.648		
12 x 6	300 x 150	21,180	22,290	662	697		19,900	20,950	622	655					

**Table 14. Flow Coefficients for Type 1098-EGR with Quick Opening Trim**

BODY SIZE		1:1 LINE SIZE TO BODY SIZE					2:1 LINE SIZE TO BODY SIZE					K <sub>m</sub>	IEC SIZING COEFFICIENT		
		C <sub>g</sub>		C <sub>v</sub>		C <sub>1</sub>	C <sub>g</sub>		C <sub>v</sub>		C <sub>1</sub>		X <sub>T</sub>	F <sub>D</sub>	F <sub>L</sub>
NPS	DN	Regulating	Wide-Open	Regulating	Wide-Open		Regulating	Wide-Open	Regulating	Wide-Open		C <sub>1</sub>			
1	25	769	810	23.9	25.2	32.2	728	766	24.5	25.7	29.8	0.70	0.656	0.36	0.84
2	50	2460	2590	68.3	71.9	36.0	2214	2331	64.4	67.8	34.4		0.820		
3	80	4790	5050	141	149	33.9	4571	4812	137	145	33.3		0.727		
4	100	8120	8550	229	242	35.4	7701	8106	225	237	34.2		0.793	0.30	
6	150	14,915	15,700	445	469	33.5	14,571	15,350	435	458	33.5		0.710	0.28	
8 x 6	200 x 150	15,770	22,470	478	681	33.0	15,410	20,100	467	609	33.0		0.689		
12 x 6	300 x 150		25,750		780			781							

**Table 15. Flow Coefficients for Type 1098-EGR with Whisper Trim™ Cage**

BODY SIZE		1:1 LINE SIZE TO BODY SIZE					2:1 LINE SIZE TO BODY SIZE					K <sub>m</sub>	IEC SIZING COEFFICIENT		
		C <sub>g</sub>		C <sub>v</sub>		C <sub>1</sub>	C <sub>g</sub>		C <sub>v</sub>		C <sub>1</sub>		X <sub>T</sub>	F <sub>D</sub>	F <sub>L</sub>
NPS	DN	Regulating	Wide-Open	Regulating	Wide-Open		Regulating	Wide-Open	Regulating	Wide-Open		C <sub>1</sub>			
1	25	576	607	16.7	17.6	34.5	529	557	15.6	16.4	34.0	0.80	0.753	0.10	0.89
2	50	1970	2080	54.7	57.8	36.0	1830	1930	52.3	55.1	35.0		0.820	0.07	
3	80	3760	3960	107	113	35.0	3630	3830	106	110	34.2		0.775	0.05	
4	100	6280	6610	180	190	34.8	6020	6340	171	180	35.2		0.766	0.04	
6	150	9450	9950	295	310	32.0	9240	9730	291	306	31.7		0.648	0.03	
8 x 6	200 x 150	10,660	11,220	305	321	35.0	10,020	10,550	286	301	35.0		0.775		
12 x 6	300 x 150	11,050	11,630	316	332		10,380	10,930	297	312					

# Bulletin 71.2:1098-EGR

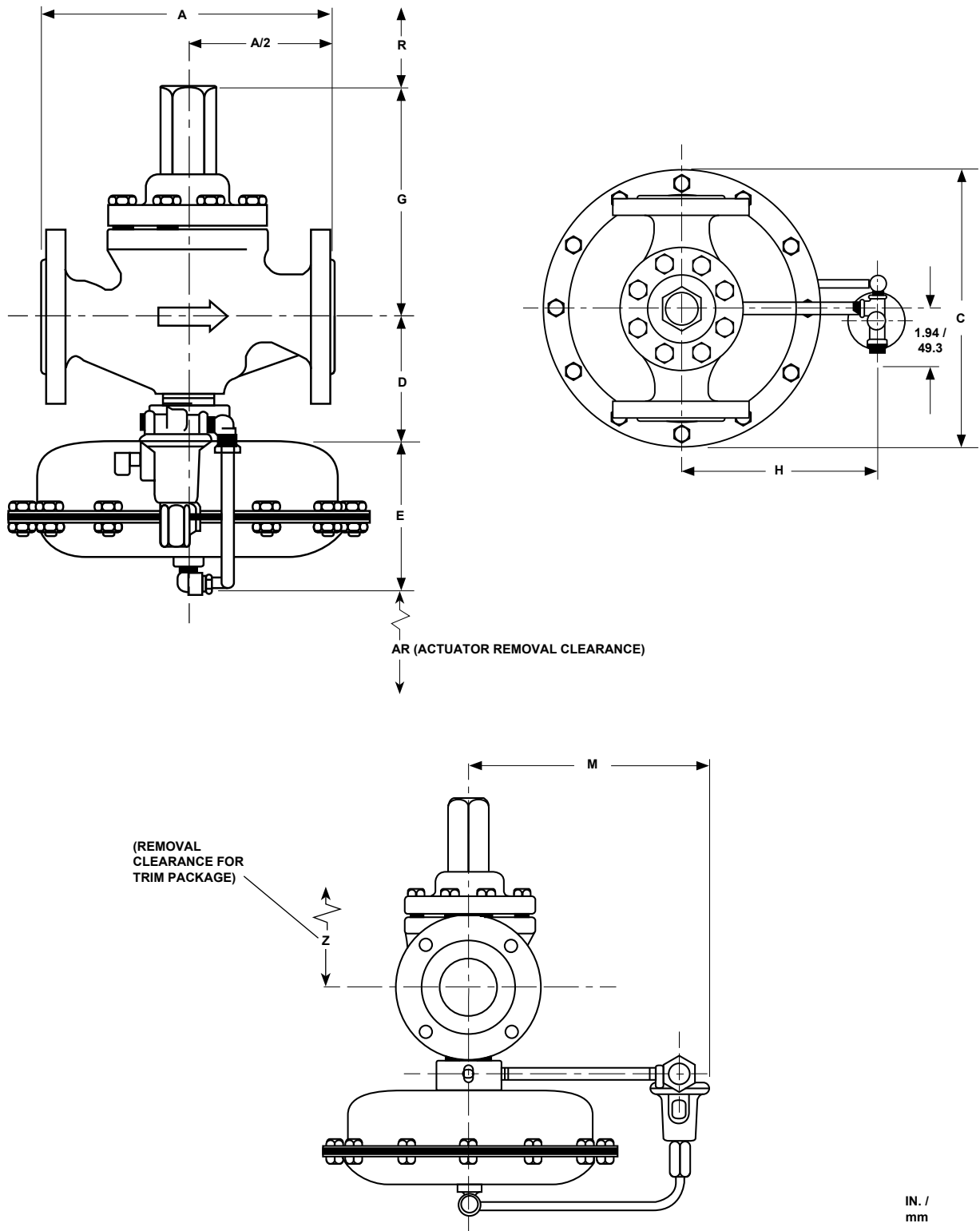

B1113\_1\_B

Figure 8. Type 1098-EGR Dimensions

**Table 16. Dimensions**

ACTUATOR DIMENSION										
Type and Actuator Size	C (Diameter)		E		H		M			
							With Pilot Spring Case Vent		Without Pilot Spring Case Vent	
	In.	mm	In.	mm	In.	mm	In.	mm	In.	mm
1098 - 30	11.38	289	5.69	145	7.88	200	9.50	241	9.31	236
1098 - 40	13.12	333	5.75	146						
1098 - 70	21.12	536	7.44	189	14.19	360	15.81	402	15.62	397
1098H - 30	11.38	289	6.06	154	7.88	200	9.50	241	9.31	236

MAIN VALVE DIMENSION																					
Body Size		A								D		G		R		Z				AR	
		NPT Cast Iron, CL600 RF, BWE or NPT Steel and Stainless Steel		CL125 FF Cast Iron or CL150 RF Steel and Stainless Steel		CL250 RF Cast Iron or CL300 RF Steel and Stainless Steel		PN 16/25/40 Steel and Stainless Steel								Cast Iron		Steel and Stainless Steel			
NPS	DN	In.	mm	In.	mm	In.	mm	In.	mm	In.	mm	In.	mm	In.	mm	In.	mm	In.	mm	In.	mm
1	25	8.25	210	7.25	184	7.75	197	7.62	194	3.88	98.6	8.62	219	4.06	103	12	305	13.75	349	3	76.2
2	50	11.25	286	10	254	10.5	267	10.19	259	4.56	116	9.12	232			13.31	338	15.06	383	3.12	79.2
3	80	13.25	337	11.75	298	12.5	317	11.81	300	5.31	135	11.31	287	5.06	129	16.5	419	18.25	464	3.88	98.6
4	100	15.5	394	13.88	353	14.5	368	13.56	344	6.56	167	12.69	322			19.12	486	21.12	536	5.12	130
6	150	20	508	17.75	451	18.62	473	17.48	444	8.06	205	13.62	346	8	203						
8 x 6	200 x 150	24	610	21.4	544	22.4	569			9.76	248	15.02	382			20.25	514	23.25	591	6.62	168
12 x 6	300 x 150	32.3	820	29	737	30.5	775			12.56	319	17.72	450								

## Ordering Information

Use the Specifications section on pages 2 and 3 and carefully review the description to the right of each specification. Use this information to complete the Ordering Guide on the following page. Specify the desired selection wherever there is a choice to be made. Then send the Ordering Guide to your local Sales Office.

## Ordering Guide

### Main Valve Body Size (Select One)

- NPS 1 / DN 25\*\*\*
- NPS 2 / DN 50\*\*\*
- NPS 3 / DN 80\*\*\*
- NPS 4 / DN 100\*\*\*
- NPS 6 / DN 150\*\*\*
- NPS 8 x 6 / DN 200 x 150  
(not available in Cast iron)\*\*\*
- NPS 12 x 6 / DN 300 x 150  
(not available in Cast iron)\*\*\*

### Main Valve Body Material and End Connection Style (Select One)

#### Cast Iron Body

- NPT (1 or 2 NPT only)\*\*\*
- CL125 FF\*\*\*
- CL250 RF\*\*\*

- continued -

## Ordering Guide (continued)

### WCC Steel Body

- NPT (1 or 2 NPT only)\*\*\*
- CL150 RF\*\*\*
- SWE (NPS 1 or 2 / DN 25 or 50 only)\*\*
- CL300 RF\*\*\*
- CL600 RF\*
- Sch 40 BWE
- Sch 80 BWE
- PN 16/25/40 (Not Available for NPS 8 x 6 or 12 x 6 / DN 200 x 150 or 300 x 150)\*  
Specify \_\_\_\_\_

### CF8M Stainless Steel

- NPT (1 or 2 NPT only)\*\*\*
- CL150 RF\*\*\*
- CL300 RF\*\*\*
- CL600 RF\*
- SWE (NPS 1 or 2 / DN 25 or 50 only)\*\*
- Sch 40 BWE
- Sch 80 BWE
- PN 16/25/40 (Not Available for NPS 8 x 6 or 12 x 6 / DN 200 x 150 or 300 x 150)\*  
Specify \_\_\_\_\_

### Cage and Cage Material (Select One)

- CF8M Stainless steel linear cage\*\*\*
- 416 Stainless steel Whisper Trim™ cage\*\*\*
- 316 Stainless steel Whisper Trim cage\*\*
- ENC coated cast iron quick opening cage\*\*\*

### Main Valve Spring (Select One)

#### Maximum Differential and Spring Color

- 20 psi / 1.4 bar, Yellow\*\*
- 60 psi / 4.1 bar, Green\*\*\*
- 125 psi / 8.6 bar, Blue\*\*\*
- 400 psi / 27.6 bar, Red\*\*\*

### Spring Material (Select One)

- Steel\*\*\*
- Inconel® X-750

### Actuator Size (Select One)

- Type 1098 Size 70, maximum set pressure 50 psig / 3.4 bar
- Type 1098 Size 40, maximum set pressure 75 psig / 5.2 bar (**standard**)
- Type 1098 Size 30, maximum set pressure 100 psig / 6.9 bar
- Type 1098H Size 30H, maximum set pressure 350 psig / 24.1 bar

### Actuator and Bonnet Material (Select One)

- Steel casing with steel bonnet\*\*\*
- Stainless steel casing with stainless steel bonnet\*\*

### Body Flange Material (Select One)

- ENC Coated cast iron\*\*\*
- ENC Coated steel\*\*\*
- ENC Coated CF8M Stainless steel\*\*

### Plug and Seat Ring (Select One)

- 416 Stainless steel\*\*\*
- 316 Stainless steel\*\*

### Diaphragm, O-rings and Other Elastomers

#### (Select One)

- Nitrile (NBR)\*\*\*
- Fluorocarbon (FKM)\*\*\*
- Ethylenepropylene (EPDM)\*\*

### Outlet Pressure Range (Select One)

#### Type 6351 Pilot

- 3 to 20 psig / 0.21 to 1.4 bar\*\*
- 5 to 35 psig / 0.34 to 2.4 bar\*\*
- 35 to 100 psig / 2.4 to 6.9 bar\*\*

#### Type 6352 Pilot

- 14 in. w.c. to 2 psig / 35 mbar to 0.14 bar\*\*\*
- 2 to 10 psig / 0.14 to 0.69 bar\*\*

#### Type 6353 Pilot

- 3 to 40 psig / 0.21 to 2.8 bar\*\*
- 35 to 125 psig / 2.4 to 8.6 bar\*\*

#### Type 6354L Pilot

- 85 to 200 psig / 5.9 to 13.8 bar\*\*

#### Type 6354M Pilot

- 175 to 220 psig / 12.1 to 15.2 bar\*\*

#### Type 6354H Pilot

- 200 to 300 psig / 13.8 to 20.7 bar\*\*

#### Type 61L, 61LD or 61LE Pilot

##### Specify Type \_\_\_\_\_

- 7 in. w.c. to 2 psig / 17 mbar to 0.14 bar\*\*
- 1 to 5 psig / 0.07 to 0.34 bar\*\*
- 2 to 10 psig / 0.14 to 0.69 bar\*\*
- 5 to 15 psig / 0.34 to 1.0 bar\*\*
- 10 to 20 psig / 0.69 to 1.4 bar\*\*

#### Type 61H Pilot

- 10 to 65 psig / 0.69 to 4.5 bar\*\*

- continued -

## Ordering Guide (continued)

### Type 61HP Pilot

- 15 to 45 psig / 1.0 to 3.1 bar\*\*
- 35 to 100 psig / 2.4 to 6.9 bar\*\*
- 100 to 300 psig / 6.9 to 20.7 bar\*\*

### Type Y600AM

- 4 to 8 in. w.c. / 10 to 20 mbar
- 7 to 16 in. w.c. / 17 to 40 mbar
- 15 in. w.c. to 1.2 psig / 37 mbar to 0.08 bar
- 1.2 to 2.5 psig / 0.08 to 0.17 bar
- 2.5 to 4.5 psig / 0.17 to 0.31 bar
- 4.5 to 7 psig / 0.31 to 0.48 bar

### Liquid Service

- Low gain restriction

### 6350 Series Pilot Construction (Select One)

- Aluminum\*\*\*
- Stainless steel\*\*

### Tubing and Fittings (Select One)

- Stainless steel tubing and steel plated fittings\*\*\*
- Stainless steel tubing and fittings\*\*\*

### Main Valve Replacement Parts Kit (Optional)

- Yes, send one replacement parts kit to match this order.

### Actuator Replacement Parts Kit (Optional)

- Yes, send one replacement parts kit to match this order.

### Pilot Replacement Parts Kit (Optional)

- Yes, send one replacement parts kit to match this order.

### Wireless Position Monitor Mounting Kit (Optional)

- Yes, send one mounting kit for mounting the Topworx™ 4310 or the Fisher® 4320 wireless position monitor.

### Option

- NACE Construction

Regulators Quick Order Guide	
***	Readily Available for Shipment
**	Allow Additional Time for Shipment
*	Special Order, Constructed from Non-Stocked Parts. Consult your local Sales Office for Availability.
Availability of the product being ordered is determined by the component with the longest shipping time for the requested construction.	

Specification Worksheet	
<b>Application:</b>	
Specific Use	_____
Line Size	_____
Gas Type and Specific Gravity	_____
Gas Temperature	_____
Does the Application Require Overpressure Protection?	
<input type="checkbox"/> Yes <input type="checkbox"/> No If yes, which is preferred:	
<input type="checkbox"/> Relief Valve <input type="checkbox"/> Monitor Regulator <input type="checkbox"/> Shutoff Device	
Is overpressure protection equipment selection assistance desired? _____	
<b>Pressure:</b>	
Maximum Inlet Pressure ( $P_{1max}$ )	_____
Minimum Inlet Pressure ( $P_{1min}$ )	_____
Downstream Pressure Setting(s) ( $P_2$ )	_____
Maximum Flow ( $Q_{max}$ )	_____
<b>Performance Required:</b>	
Accuracy Requirements?	_____
Need for Extremely Fast Response?	_____
<b>Other Requirements:</b> _____	
_____	

## Industrial Regulators

### Emerson Process Management Regulator Technologies, Inc.

USA - Headquarters  
McKinney, Texas 75070 USA  
Tel: +1 800 558 5853  
Outside U.S. +1 972 548 3574

Asia-Pacific  
Shanghai 201206, China  
Tel: +86 21 2892 9000

Europe  
Bologna 40013, Italy  
Tel: +39 051 419 0611

Middle East and Africa  
Dubai, United Arab Emirates  
Tel: +971 4811 8100

## Natural Gas Technologies

### Emerson Process Management Regulator Technologies, Inc.

USA - Headquarters  
McKinney, Texas 75070 USA  
Tel: +1 800 558 5853  
Outside U.S. +1 972 548 3574

Asia-Pacific  
Singapore 128461, Singapore  
Tel: +65 6770 8337

Europe  
Bologna 40013, Italy  
Tel: +39 051 419 0611  
Chartres 28008, France  
Tel: +33 2 37 33 47 00

Middle East and Africa  
Dubai, United Arab Emirates  
Tel: +971 4811 8100

## TESCOM

### Emerson Process Management Tescom Corporation

USA - Headquarters  
Elk River, Minnesota 55330-2445, USA  
Tels: +1 763 241 3238  
+1 800 447 1250

Europe  
Selmsdorf 23923, Germany  
Tel: +49 38823 31 287

Asia-Pacific  
Shanghai 201206, China  
Tel: +86 21 2892 9499

For further information visit [www.emersonprocess.com/regulators](http://www.emersonprocess.com/regulators)

The Emerson logo is a trademark and service mark of Emerson Electric Co. All other marks are the property of their prospective owners. Fisher is a mark owned by Fisher Controls International LLC, a business of Emerson Process Management.

*The contents of this publication are presented for informational purposes only, and while every effort has been made to ensure their accuracy, they are not to be construed as warranties or guarantees, express or implied, regarding the products or services described herein or their use or applicability. We reserve the right to modify or improve the designs or specifications of such products at any time without notice.*

Emerson Process Management Regulator Technologies, Inc. does not assume responsibility for the selection, use or maintenance of any product. Responsibility for proper selection, use and maintenance of any Emerson Process Management Regulator Technologies, Inc. product remains solely with the purchaser.